



MAGNUM CONTROLS

REFR V17

Rev. 2.8 - 2021-06-02

5580 Enterprise Pkwy.
Fort Myers, FL 33905

Office: 239-694-0089
Fax: 239-694-0031

www.mcscontrols.com



**MCS Total
Solution
for all your
Control
Needs**



**Energy Efficient and
RoHS Compliant**



Storage Climate Controls

The MCS Commitment is to provide practical solutions for the industries needs and to be both a leader and partner in the effective use of microprocessor controls.

Micro Control Systems, Inc.
5580 Enterprise Parkway
Fort Myers, Florida 33905
PH:(239) 694-0089 FAX:(239) 694-0031
www.mcscontrols.com

All information contained within this document is considered to be proprietary information of Micro Control Systems, Inc. No information or data from this document shall be published, used, reproduced, transmitted, or disclosed to others outside your organization without the prior expressed written consent of Micro Control Systems, Inc. This document and the information contained herein shall be treated as proprietary. Reasonable provisions shall be provided to ensure that this information remains proprietary by your employees, agents, and other personnel that may have access to this document. Copyright ©2020

Table of Contents

Chapter - 1.	Purpose of the REFR software	9
1.1.	Compressor Control	9
1.2.	Defrost	9
Chapter - 2.	Introduction to the Magnum	10
	Magnum V17 Software Control Point Capacity	10
	Magnum Hardware Supported by Magnum V17 Software	10
Chapter - 3.	MCS-MAGNUM-N and Expansion Boards	12
3.1.	MCS-Magnum Revision 9.1.....	12
3.2.	MCS-SI16-A04- Version 1.3	13
3.3.	MCS-RO10 - Version 1.2.....	13
3.4.	MCS-Magnum-N-12 Revision 9.2.....	14
3.4.1	Optional Single Output Power Supply	14
3.5.	MCS-IO-BASE and MCS-IO-EXT	15
3.6.	MCS-RO-BASE and MCS-RO-EXT	18
3.7.	MCS-SI-BASE and MCS-SI-EXT	19
Chapter - 4.	Network Connection–MCS-485	20
4.1.	MCS 485 Network	20
Chapter - 5.	Network Connection–Ethernet	21
5.1.	ETHERNET	21
5.1.1	RJ45 using a Crossover Ethernet Cable	21
Chapter - 6.	Network Connection–Remote	22
6.1.	Remote using Ethernet.....	22
Chapter - 7.	PC Software for the Magnum	23
7.1.	Requirements for PC Software.....	23
Chapter - 8.	Authorization Function	24
8.1.	Authorization Function	24
Chapter - 9.	Standard Control Options	26
9.1.	General Options	26
9.2.	Variable Capacity Control Method	26
9.2.1	Screw Compressor with slide piston.....	26
9.2.1.1.	Force Digital Compressor Speed	27
9.2.2	Compressor with a Variable Frequency Drive (VFD).....	27
9.2.3	Example of a system with 3 variable Step Compressors.....	27
9.2.4	Compressor Types.....	27
9.2.5	Condenser Options.....	28
9.3.	Target Reset (only if temperature control)	28
9.4.	Oil Differential Calculation	28
9.5.	On/Off Switches.....	28
9.6.	Low Suction Unloading & Holding	29
9.7.	High Discharge Pressure Unloading & Holding.....	29
9.8.	High Discharge Temperature Unloading & Holding.....	29
9.9.	High Ampere Unloading & Holding	30
9.10.	Control Power Relay –No Stop.....	30
9.11.	Part Wind or Star Delta Starter.....	30
9.12.	English or Metric sensor readings	31
9.13.	Compressor Auto Rotation	31
9.14.	Expanded Compressor Rotation to Check for Maximum Run Time.....	32
9.15.	Run Hour Lockout.....	32
9.16.	Compressor Anti-Cycle Logic	32
9.17.	Warning & Alarm Relay Outputs.....	33
9.18.	Operating Schedules	33
9.19.	Modification to adjust approach values	33
Chapter - 10.	Magnum Control Zone	34

10.1.	Control Method Option	34
10.2.	Common Definitions	34
10.2.1	Target.....	34
10.2.2	Control Zone	34
10.2.3	Control Sensor.....	35
10.2.4	Control Input Rate of Change	35
10.2.5	Step Delay and Sensitivity	35
Chapter - 11.	Magnum Voltage SI Control Method	36
11.1.	Number of steps supported:	36
11.2.	Common Definitions	36
11.2.1	Targets, Stage Cut In Values	36
11.2.2	Stage Cut Out Values	36
11.2.2.1.	Step Delay	36
11.2.2.2.	Controlling Sensor	36
Chapter - 12.	REFR Defrost	37
12.1.	Defrost cycle initialization:	37
12.2.	Approach type setup.....	38
12.2.1	Approach type based circuit evaporator temperature	39
12.3.	Defrost Ready Indicator	40
12.4.	Defrost Indicator	40
12.5.	Defrost Indicator setup	40
12.6.	Defrost Types supported:	41
12.7.	Defrost - Time Off	41
12.8.	Defrost - Reverse Cycle	41
12.9.	Defrost - Electric.....	41
12.10.	Defrost - Hot Gas - Conventional (set point #117 = Active).....	42
12.11.	Defrost - Hot Gas on the Fly (set point #117 = Inactive).....	42
12.12.	Rotating Compressor Air Defrost Selection:.....	43
12.12.1	Defrost function:	43
12.12.2	Defrost is initiated	44
12.13.	Defrost - Multiple Evaporator/Reheat	44
12.13.1	Purpose of Multiple Evaporator/Reheat:	44
12.13.2	Multiple Evaporator/ Reheat (normal) Selection:	44
12.13.3	Compressor Info window:	44
12.13.4	Evaporator Info window:	44
12.13.5	Circuit Base:.....	44
12.13.6	Relay output sequence for a variable compressor with 4 EVAP/REHT:	44
12.13.7	Relationship of evaporators and reheat:.....	45
12.13.8	Set points that support this selection:	45
12.13.9	Defrost; Electric type with multiple evaporator/reheat relays:.....	45
12.14.	Unit Operating with the Evaporator/Reheat Selection	46
12.14.1	Unit is in normal mode (not dehumidification) & circuit is on	46
12.14.2	1.3.2 Unit is in dehumidification mode & circuit is on	46
12.14.3	Unit is a normal mode & circuit is off.....	46
12.14.4	Unit is a NOT in a normal mode (RUN/STOP, Emergency Stop etc.).....	46
Chapter - 13.	Dehumidify Function	47
Chapter - 14.	Common Definitions	48
14.1.	How a Defrost Cycle can be initiated.....	48
14.1.1	Approach Set point Temperature & Time (Air Defrost).....	48
14.1.2	Approach Set point Temperature & Time (Standard Defrost)	48
14.1.3	Approach Actual Temperature & Time	48
14.1.4	Defrost Fan Relay.....	49
14.1.5	Defrost Slave	49
Chapter - 15.	Magnum Displays	50
15.1.	Menu Key	50
15.2.	Status Display – Chiller (Default at Power Up).....	50
15.3.	Status Display – Circuit (x)	50

15.4.	Outputs	51
15.5.	Inputs	52
15.6.	Alarms	53
15.7.	Graphs.....	53
15.8.	Set points	53
15.9.	Service Tools	57
Chapter - 16.	Control Status Display	58
16.1.	From the MCS-Connect program	58
16.1.1	Information displayed:.....	58
Chapter - 17.	Magnum Control States	60
Chapter - 18.	Capacity Control States (number)	61
18.1.	UNIT IN POWER UP (0).....	61
18.2.	POWER LOSS DELAY (1).....	61
18.3.	NO RUN- I/O LOST (2).....	61
18.4.	UNIT IN LOCKOUT (3).....	61
18.5.	UNIT IS OFF (4)	62
18.6.	UNIT IS HOLDING (5)	62
18.7.	UNIT UNLOADING (6)	62
18.8.	UNIT IS LOADING (7)	62
18.9.	CMP IN STARTU (8).....	62
18.10.	RUN/STOP SW OFF (9).....	62
18.11.	SCHEDULED OFF (10).....	62
18.12.	OFF- NO FLOW(s) (11)	62
18.13.	NOT USED (12).....	63
18.14.	NOT USED (13).....	63
18.15.	NOT USED (14).....	63
18.16.	UNIT IS UNLOADED (15)	63
18.17.	UNIT IS LOADED (16).....	63
18.18.	NOT USED (17).....	63
18.19.	NOT USED (18).....	63
18.20.	NOT USED (19).....	63
18.21.	DEF-STARTING CMP (20) (only used if not Air Normal Defrost)	63
18.22.	DEFROSTING COILS (21) (only used if not Air Normal Defrost).....	63
18.23.	LO TEMP UNLOAD (22).....	63
Chapter - 19.	Circuit Control States (number)	64
19.1.	LOST IO LOCKED (0)	64
19.2.	CMP LOCKED OUT (1).....	64
19.3.	SWITCHED OFF (2).....	64
19.4.	UNLD & PMPDWN (3).....	64
19.5.	CMP ANTICYCE (4)	64
19.6.	CMP OFF/READY (5).....	64
19.7.	NOT USED (6).....	64
19.8.	NOT USED (7).....	64
19.9.	CMP UNLOADED (8)	65
19.10.	CMP UNLD STEP1 (9)	65
19.11.	CMP UNLD STEP2 (10)	65
19.12.	CMP IS HOLDING (11).....	65
19.13.	CMP IS LOADING (12).....	65
19.14.	CMP IS UNLDING (13).....	65
19.15.	CMP IS RUNNING (14)	65
19.16.	FAST UNLOADING (15).....	65
19.17.	LO SUCT UNLOAD (16).....	65
19.18.	LO SUCT HOLD (17).....	66
19.19.	HI DISC UNLOAD (18).....	66
19.20.	HI DISC HOLD (19)	66
19.21.	SAFETY TRIPPED (20).....	66
19.22.	NOT USED (21).....	66
19.23.	HI AMP UNLDING (22).....	66

19.24.	HI AMP HOLD (23)	66
19.25.	HI DIS TMP HLD (24)	67
19.26.	NOT USED (25)	67
19.27.	NOT USED (26)	67
19.28.	HI WATER HOLD (27)	67
19.29.	DEFROST EVAP1 (28) (not Rotating Coil Air Defrost Only)	67
19.30.	DRIP DOWN #1 (29) (not Rotating Coil Air Defrost Only)	67
19.31.	DEFROSTR EVAP2 (30) (not Rotating Coil Air Defrost Only)	67
19.32.	DRIP DOWN #2 (31) (not Rotating Coil Air Defrost Only)	67
19.33.	DEF-START CMP (32) (not Rotating Coil Air Defrost Only)	67
19.34.	DEF-PUMP DOWN (33)	67
19.35.	DEFROST COILS (34)	68
19.36.	DEF-AIR NORMAL (35)	68
19.37.	NOT USED (36)	68
19.38.	CMP OFF/D-DOWN (37)	68
19.39.	CMP OFF/DefAIR (38) (only used if Air Defrost)	68
19.40.	DEFcmp&val OFF (39)	68
19.41.	LO TEMP HOLD (40)	68
19.42.	HI TEMP UNLOAD (41)	68
19.43.	HI TEMP HOLD (42)	68
Chapter - 20.	Condenser Control Logic	69
20.1.	Condenser Introduction	71
20.1.1	RO Step Condenser Cut In – Out Logic	71
20.1.2	RO Step Condenser with Variable Speed Fan	72
20.1.2.1.	Condenser Control	72
20.1.2.2.	Common Terms	72
20.1.2.3.	Control Discharge Pressure Calculation	72
20.1.2.4.	Condenser Reset	74
20.1.2.5.	Condenser Low Ambient	74
20.1.2.6.	Condenser Related Setpoints	75
20.2.	CONDENSER TYPES	76
20.2.1	No Condenser	76
20.2.2	RO Step Common	76
20.2.3	RO Step Common with a Fan AO and Condenser Faults	77
20.2.4	RO Step Individual	78
20.2.5	RO Step Combined	79
20.2.6	Modulating	79
20.2.6.1.	Modulating Common	79
20.2.7	Modulating Step Common	80
20.2.8	Modulating Individual	81
20.2.9	RO Step Shared	81
20.2.10	Dual V8	81
20.2.11	Common VFD Fan w/Bypass	82
20.2.12	Evaporative types of Condenser Control	84
20.2.12.1.	Viewing on MCS-CONNECT and MCS-MAGNUM LCD KEYPAD	84
20.2.13	PID MOD Individual	85
20.2.14	PID Step Common	86
20.3.	PID CONTROL	87
Chapter - 21.	User Logic	88
21.1.	Operands	88
21.2.	Operators	89
21.3.	User Sensor Input	90
21.3.1	Examples of User Logic Sensor Inputs	90
21.4.	User Relay Output	91
21.5.	User Analog Output	92
Chapter - 22.	Electronic Expansion Valve Control Logic (EXV)	93
22.1.	Electronic Expansion Valve Control Logic (EXV)	93
22.1.1	EXV Control States	94

22.1.2	EXV Maximum Operating Pressure.....	95
22.1.3	EXV control methods for Step Loading Compressors	95
Chapter - 23.	EXV Control SSH, SSH2	96
23.1.	Fast Suction Superheat (Fast SSH)	96
23.2.	Fast Suction Superheat 2 (Fast SSH2)	96
23.3.	Selecting Fast SSH or Fast SSH2 in MCS-Config	96
23.4.	Circuit Base	96
23.4.1	Selecting the 'EXV Control' tab you are prompted with the following:	97
23.4.2	Selection Options.....	97
23.4.3	Compressor EXV Results.....	98
23.4.4	MCS EXV Factory Default Set Point.....	99
23.4.4.1.	Fast SSH2, Suction Superheat, Plate HX	99
23.4.4.2.	Fast SSH2, Suction Superheat, DX Coil	99
23.4.4.3.	Fast SSH, Suction Superheat, DX Barrel	99
23.4.4.4.	Fast SSH2, Discharge Superheat, DX Barrel.....	99
23.4.4.5.	Fast SSH, Suction Superheat, DX Barrel	100
23.4.4.6.	Suct Spht, Suction Superheat, DX Barrel.....	100
23.5.	Set Point Descriptions (Fast SSH & Fast SSH2).....	100
23.5.1	Set Point Adjustments.....	102
23.5.2	Low Suction Multiplier-SP 13	102
23.5.2.1.	Low Superheat Adjustment-SP 15	102
23.5.2.2.	EXV Startup Time-SP 20	102
23.5.2.3.	EXV Compressor Start Delay-SP 20	102
23.5.2.4.	EXV Target & EXV Fast Zone-SP 9	102
23.6.	Fast SSH States	103
23.6.1	FAST SSH2 State Format.....	103
Chapter - 24.	General Introduction to EXV PID	104
24.1.	MCS PID REQUIREMENTS.....	104
24.2.	Calculations for the adjustment to EXV valve.....	104
24.3.	EXV PID Firmware	104
24.4.	MCS PID REQUIREMENTS.....	105
24.5.	Selecting PID in MCS-CONFIG.....	105
24.6.	Circuit Base	105
24.7.	Selecting the 'EXV Control' tab you are prompted with the following:	106
24.8.	Selection Options	106
24.9.	Compressor EXV Results.....	107
24.10.	Set Point Descriptions (PID).....	107
24.11.	PID Example Setpoint Defaults	109
24.12.	Logic to Determine which K Multipliers to Use	110
24.12.1.1.	Switching to Fast K multipliers is based on:	110
24.12.1.2.	Switching to Slow K multipliers is based on:	110
24.12.1	Rate of Change_ - Moving too Fast.....	111
24.12.2	Rate of Change - Moving Slow Enough.....	111
24.13.	MCS-Connect Evaporator EXV PID Status	112
24.14.	Allowing an Adjustments to the EXV Valve.....	112
Chapter - 25.	EXV Level Control using PID	113
25.1.	Setting up EXV Level Control.....	113
25.1.1	Setting up EXV Level Control – User Defined	113
25.1.2	Circuit Base Setup	115
25.1.3	Setup using EXV CONTROL WIZARD	115
25.1.4	Low Discharge Superheat EXV Target Adjust Logic.....	116
25.1.4.1.	The Low Discharge Superheat logic:.....	116
Chapter - 26.	Analog Output Control using PID	118
Chapter - 27.	Hardware & Software support information	120
27.1.	OEM Factory Checkout Procedure.....	120
27.2.	Hardware Trouble Shooting.....	120
27.3.	The MCS Trouble Shooting Quick Reference Sheet.....	120

Chapter - 28. MODBUS RTU	123
28.1. Setup the Modbus from MCS-Config's Magnum Setup Screen(see below):.....	123
28.2. From MCS-Connect's Service Window RS485 tab(see below):.....	124
28.3. From MCS-Magnum LCD/Keypad(see below):	124
28.4. In MCS-CONFIG you can see & print a list of the Modbus Registers (see below):.....	125
Chapter - 29. BMS Communication Protocols	126
29.1. MCS-Magnum to BMS Connections	126
29.2. Sensor Input Points	127
29.3. Relay Output Points.....	128
29.4. Setpoints.....	129
29.5. Chiller/Compressor States.....	129
29.6. Other Points.....	130
29.7. Network inputs to MCS-Magnum.....	132
Chapter - 30. REFR Unit and Compressor State Chart	134
30.8.1 BACNET OVER IP PROTOCOL.....	135
30.8.2 ETHERNET NETWORK PROTOCOL	135
29.7.1 MODBUS RTU PROTOCOL.....	136
29.7.2 MODBUS TCP/IP PROTOCOL.....	136
29.8. PROTOCOLS USING MCS-BMS-GATEWAY	136
Chapter - 31. NETWORK PROTOCOLS	137
31.1. Protocols MCS controllers support:	137
31.2. MCS-MAGNUM USING RS-485	138
31.3. Wiring Multiple MCS Controllers.....	139
31.4. MCS-MAGNUM USING ETHERNET	140
31.5. EXAMPLE NETWORK	141
31.5.1 Standalone MCS-Magnum	141
31.5.2 MULTIPLE MCS-MAGNUM ENCLOSURES	142
31.6. MULTIPLE MCS-MAGNUM BMS RS485 WIRING DIAGRAM.....	143
Chapter - 32. Set Point Definitions	144
32.1. Setpoint Types.....	145
32.1.1 SETPOINT	145
32.1.2 LOCKOUT.....	145
32.1.3 ALARM.....	145
32.1.4 Time	145
32.1.5 Target.....	145
32.1.6 Delay.....	145
32.2. Window/Safety extension	146
32.2.1 Time and seconds to ignore for setpoints	146
32.3. Set points for MAG REFR V17 Software	147
Chapter - 33. Magnum Alarms and Safeties	164
33.1. Introduction.....	164
33.2. Information only Alarms	164
33.2.1 System Generated Alarms.....	164
33.2.2 Alarms As A Result Of Individual Action.....	164
33.2.3 Alarms Generated By The Control Algorithm.....	164
33.3. Magnum System Alarms	165
33.3.1 Alarms Are Generated By The Magnum Control Algorithm:	165
33.3.1.1. Configuration Problem Alarms.....	165
33.3.1.2. Mcs Local Network Problem Alarms.....	165
33.3.1.3. Key Sensors Problem Alarms	165
33.3.1.4. EMERGENCY STOP Alarm.....	165
33.4. Set Point Safety Alarms.....	165
33.4.1 Introduction	165
33.4.2 Sensor Inputs used In Conjunction with Magnum Set Point Safeties:.....	166
33.4.3 Set Point Safeties	166

Chapter - 1. Purpose of the REFR software

The purpose of the REFR software is to provide refrigeration that requires meeting stringent temperature requirements. This includes compressor control and provides defrost capabilities when needed.

1.1. Compressor Control

All of safeties and proactive steps that have been developed by MCS in compressor control are included. Compressors supported include fixed step compressors with or without loaders/unloaders or variable speed capabilities and screw compressors.

1.2. Defrost

This is a procedure, performed periodically to maintain the systems operating efficiency by removing any ice build-up in the evaporators. A number of defrost methods are supported, refer to documentation on the following pages.

The type that best suits the installation is selected via the MCS-CONFIG program.

Chapter - 2. Introduction to the Magnum

Software

REFRIG V17—This software supports all types of compressors except centrifugals. It supports the configuration type 118 Chiller V17 CFG. If this software is loaded into a Magnum with a different type of configuration file, an invalid configuration type message will be generated.

About the Magnum

The Magnum controller is a microprocessor-based control system designed to provide complete control of many different types of compressors of both fixed and variable capacity, as well as many additional features. Supported control options include multiple liquid line solenoids, electronic expansion valves (EXVs), liquid injection, economizers, hot gas bypass, variable frequency drives for compressors (VFDs), digital scrolls, and many more.

Applications vary from control of a single compressor to complex multiple compressor systems.

In all applications, however, safety and operating efficiency is of primary importance.

The controller interface is made to be informative and meaningful, with built-in logic to prevent unsafe conditions from occurring. This helps reduce or even completely eliminate nuisance alarms.

Magnum V17 Software Control Point Capacity

- Circuits (compressors) up to 20
- Steps per Compressor up to 4
- Relay Outputs up to 80
- Analog Outputs up to 28
- Sensor Inputs up to 112
- Setpoints 255
- Alarms 100

Magnum Hardware Supported by Magnum V17 Software

The following MCS boards can be connected together through the MCS-I/O communications terminal block:

- MCS-Magnum (115/230 or 24vac) - 12 sensor inputs, 10 relay outputs, 4 analog outputs, 4 digital outputs
- MCS-RO10 (115/230 or 24vac) - 10 relay outputs
- MCS-SI16-AO4 (115/230 or 24vac) - 16 sensors and 4 analog outputs

Effective 3rd quarter 2019 (+12 system)

- MCS-Magnum-N-12 (12vac system) 12 sensor inputs, 10 relay outputs, 4 analog outputs, 4 digital outputs
- MCS-IO-BASE - 16 sensors, 4 analog outputs and 10 relay outputs
Add MCS-IO-EXT - 32 sensors total, 8 analog outputs total and 20 relay outputs total, same footprint
- MCS-RO-BASE - 10 relay outputs
Add MCS-RO-EXT - 20 relay outputs total, same footprint
- MCS-SI-BASE - 16 sensors, 4 analog outputs
Add MCS-SI-EXT - 32 sensors total, 8 analog outputs total, same footprint

The versatility of the Magnum offers the user much flexibility in configuring the controls in an economical way. The limitation is not the number of boards but the total number of set points.

MCS-MAGNUM HARDWARE

REV. 9.1

- ◆ MCS-MAGNUM hardware has been modified and its new revision number is - 9.1
- ◆ Hardware modification - Ethernet PHY chip was replaced due to obsolescent of the old Ethernet PHY chip by the manufacturer.
- ◆ **NEW ETHERNET PHY CHIP REQUIRES NEW FIRMWARE TO FUNCTION.**

FOLLOWING FIRMWARE VERSIONS (OR GREATER) ARE REQUIRED FOR MAGNUM HARDWARE VERSION 9.1

V7:

HVAC 07.03-V
CENT 07.03-V
REFR 07.03-V

V9:

HVAC 09.14-P
CENT 09.14-P
REFR 09.14-P
RTUM 09.14-P
PAO 09.14-P
ACU 09.14-P

V16:

HVAC 16.11-G
CENT 16.11-G
REFR 16.11-G
RTUM 16.11-G
PAO 16.11-G
ACU 16.11-G

V17:

HVAC 17.26-A or greater
CENT 17.26-A or greater
REFR
RTUM 17.26-A or greater
PAO 17.26-A or greater
ACU 17.26-A or greater

Chapter - 3. MCS-MAGNUM-N and Expansion Boards

3.1. MCS-Magnum Revision 9.1



MCS-MAGNUM-N 115-230vac-Selectable Power

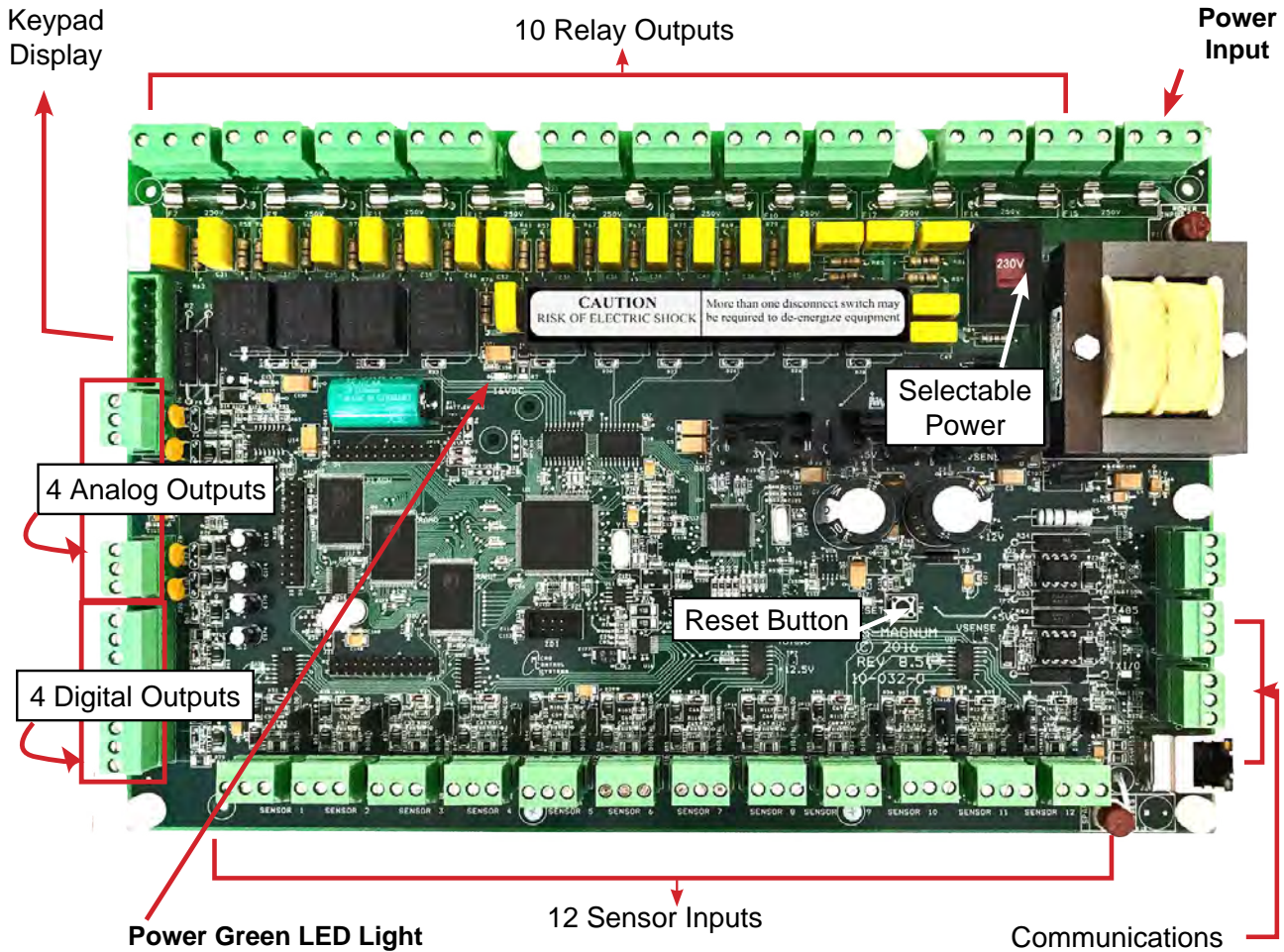

Controller Specifications

Dimensions..... 12.0"w, 8.0"h, 2.0"d
 Mounting Holes..... Mounts on a backplane using eight #6 sheet metal screws
 Operating Temperature -40°F to +176°F (-40°C to +80°C)
 Storage Temperature ... -40°F to +176°F (-40°C to +80°C)
 Microprocessor Zilog eZ80 Acclaim! @ 50mhz
 Sensor Inputs (SI)..... 12 inputs 0-5vdc (10-bit A/D)
 Digital Inputs 4 inputs 0 or 5vdc only
 Relay Outputs (RO) 10 outputs 6.3amps @ 230vac
 Analog Outputs (AO) .. 4 outputs 0-10vdc
 Printed Circuit Board... Six layer with separate power and ground planes

Input Power (Standard). 115 or 230vac ±10% 50/60Hz @ 77°F (25°C) ambient, 20VA max (Voltage is field selectable)

MCS-I/O Comm Port.. 1 @ 38,400 baud
 RS-485 Comm Port 1 @ 19,200 baud
 Ethernet 10/100 Mbps Ethernet
 Real Time Clock..... Battery backup
 Power Detection Automatic power fail reset

Options

-24..... 24vac input power ±10%
 50/60Hz @ 77°F (25°C) ambient

3.2. MCS-SI16-A04- Version 1.3

The MCS-SI16-A04 provides a flexible and cost effective way to allow sensor input and analog output expansion for MCS MAGNUM and MicroMag controllers

Input Power (Standard) 115 or 230vac ±10% 50/60Hz
 Optional 24vac input power ±10% 50/60Hz

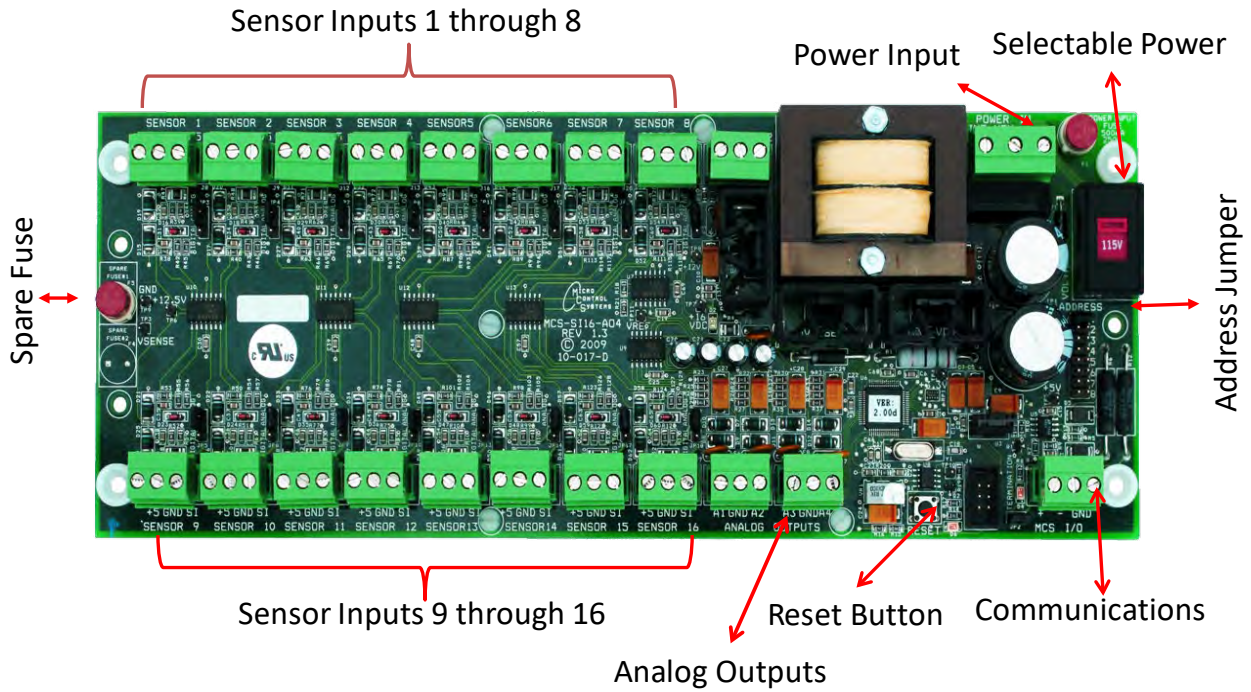

3.3. MCS-RO10 - Version 1.2

The MCS-RO10 provides a flexible and cost effective way to allow relay output expansion for MCS-MAGNUM and 1MicroMag controllers.

Input Power (Standard) 115 or 230vac ±10% 50/60Hz
 Optional 24vac input power ±10% 50/60Hz

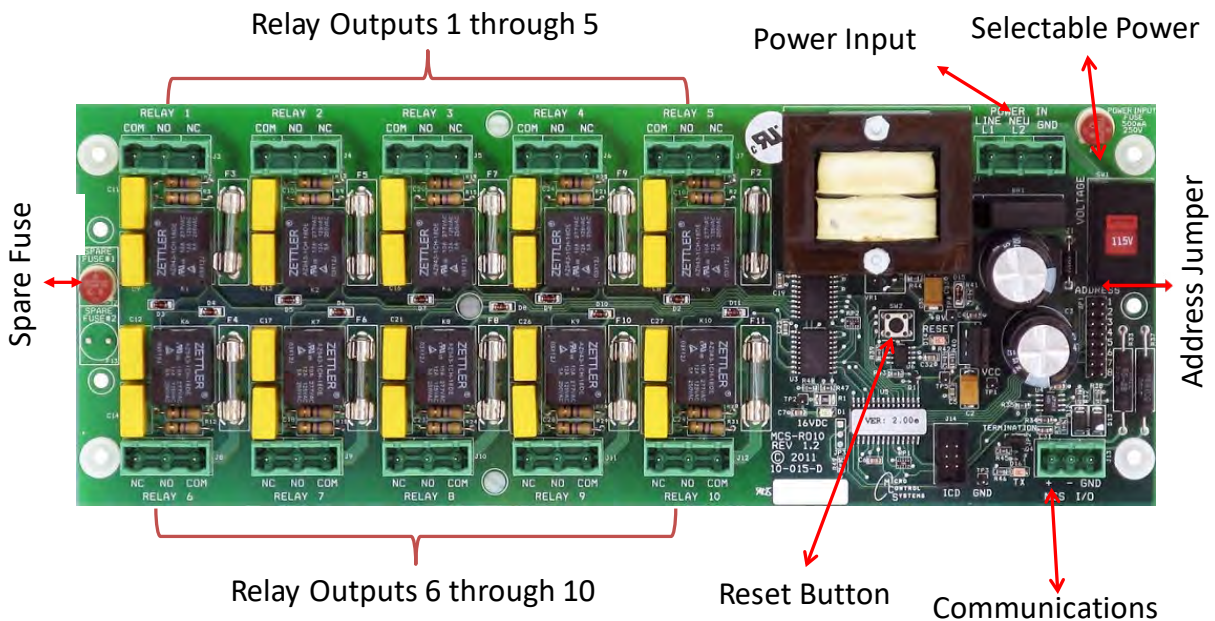

3.4. MCS-Magnum-N-12 Revision 9.2

Firmware Version required - see previous section

Input Power (Standard) +12vdc power in board from 95 - 265vac switching power supply

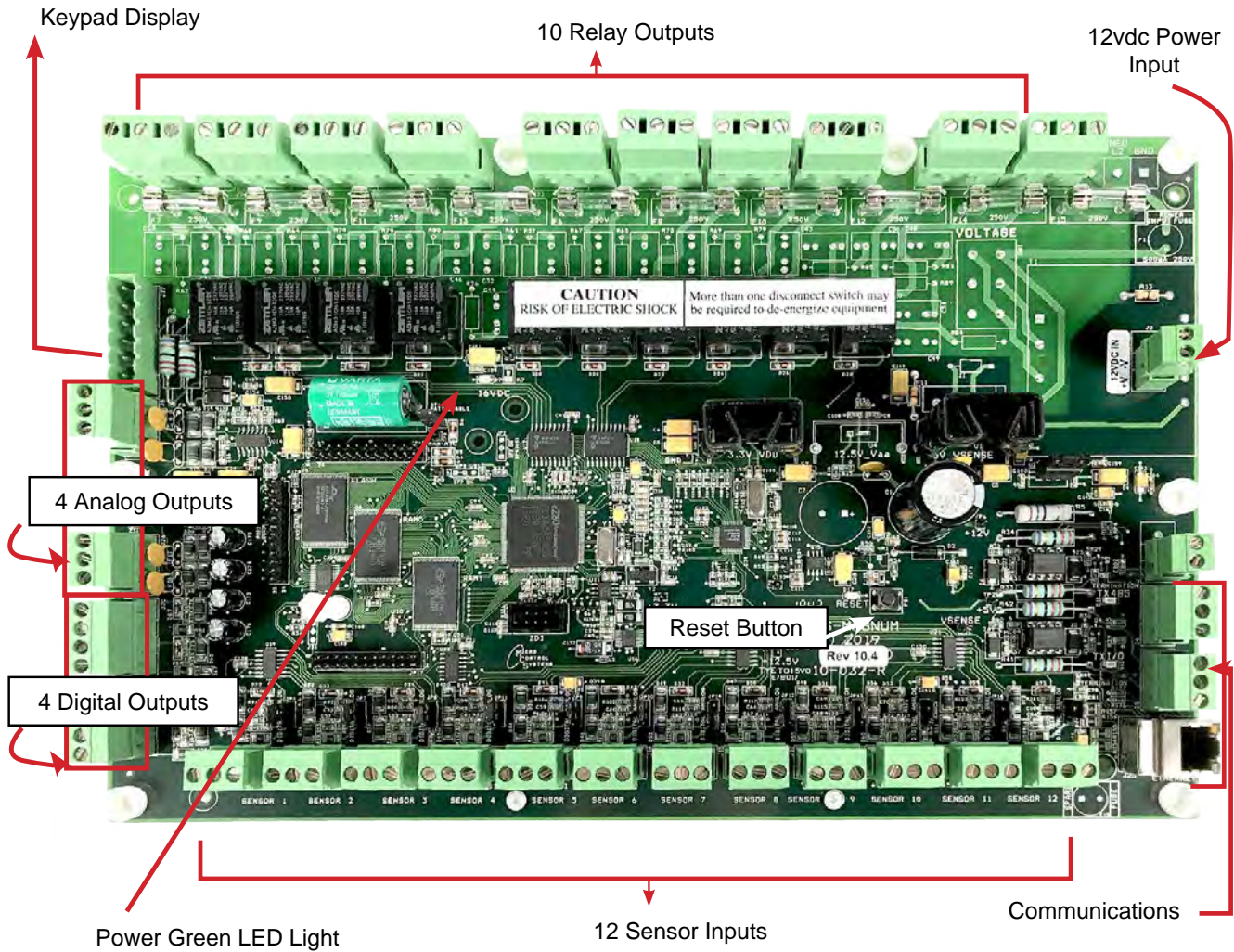

3.4.1 Optional Single Output Power Supply



100W Single Output Power Supply
 Size: (L X W X H) (Inches):
 6.3 x 3.8 x 1.5 inches
 12Volts @ 8.5Amps

Power Supply is based on number of expansion boards that are being used in the system.

3.5. MCS-IO-BASE and MCS-IO-EXT

The MCS-IO-BASE provides a flexible and cost effective way to allow relay output, sensor input and analog output expansion for MCS MAGNUM-N-12.

Using a Single Output Power Supply the MCS-IO can be used with 115-230 or 24 volt MCS-MAGNUM-N or MicroMag systems.

Using the stackable MCS-IO-EXT you can double the number of inputs and outputs in the same footprint in your enclosure or mounted to a backplane.

Photo below shows MCS-IO-BASE and MCS-IO-EXT mounted in a stackable array.

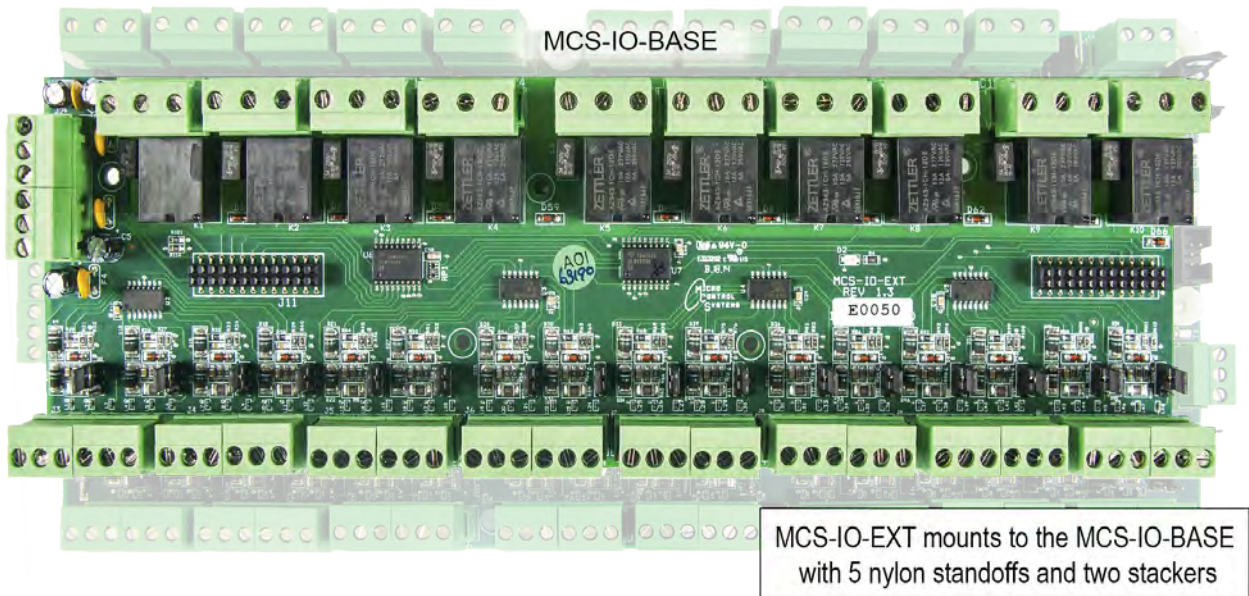

MCS-IO-BASE and MCS-IO-EXT

- Dimensions 12.0”l, 5.5”w, 2.50”h
- MountingMounts on a backplane using six #6 sheet metal screws
- Operating Temperature -40°F to +158°F (-40°C to +70°C)
- Operating Humidity..... 0-95% Non-Condensing
- Storage Temperature -40°F to +158°F (-40°C to +70°C)
- Sensor Inputs..... 16 0-5vdc on base - 32 total with MCS-IO-EXT
- Analog Outputs 4 outputs 0-10vdc on base - 8 total with MCS-IO-EXT
- Relay Outputs 10 outputs 5amps @ 230VAC on base - 20 total with MCS-IO-EXT
- Printed Circuit Board..... Four layer with separate power and ground planes
- Input Power (Standard)..... 12VDC Regulated power supply
- MCS-I/O Comm Port..... 1 @ 38,400 Baud
- Power Detection..... Automatic Power Fail Reset

Theory for settings one MCS-IO-BASE plus extension boards

1. Address settings for installing MCS-IO-BASE and MCS-IO-EXT expansion boards:

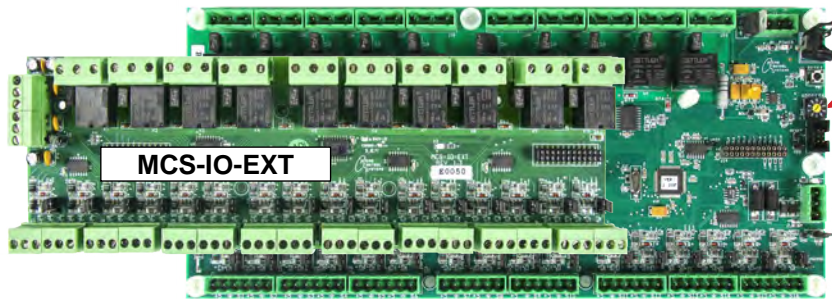

MCS-IO-Base - Set to #1
***Mount a MCS-IO-EXT
address automatically
is assigned #2***

2. Adding MCS-RO-BASE, MCS-RO-EXT

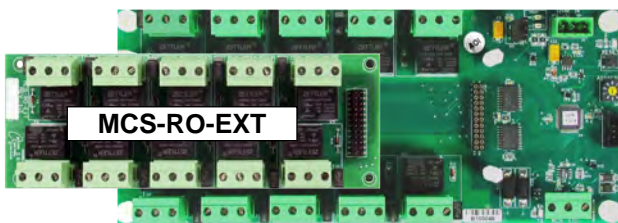

MCS-RO-Base - Set to #3
***Mount a MCS-RO-EXT
address automatically
is assigned #4***

3. Adding MCS-SI-BASE, MCS-SI-EXT

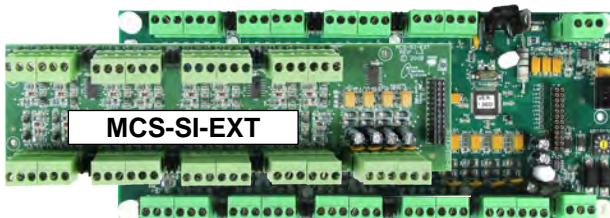

MCS-SI-Base - Set to #3
***Mount a MCS-SI-EXT
address automatically
is assigned #4***

SEE NEXT PAGE - ADDING A SECOND MCS-IO-BASE

Theory for settings two MCS-IO-BASE boards plus extension board

1. Address settings for installing MCS-IO-BASE and MCS-IO-EXT expansion boards:

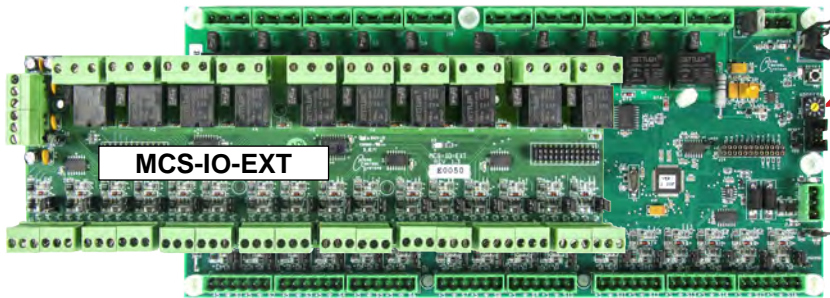

MCS-IO-BASE #1

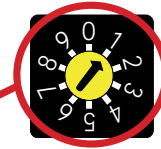

MCS-IO-Base - Set to #1
***Mount a MCS-IO-EXT
address automatically
is assigned #2***

2. Adding second MCS-IO-BASE



MCS-IO-BASE #2



MCS-IO-Base - Set to #3

3.6. MCS-RO-BASE and MCS-RO-EXT

The MCS-RO-BASE provides a flexible and cost effective way to allow relay output expansion for MCS MAGNUM-N-12.

Using a Single Output Power Supply the MCS-RO can be used with 115-230 or 24 volt MCS-MAGNUM-N or MicroMag systems.

Using the stackable MCS-RO-EXT you can double the number of inputs and outputs in the same footprint in your enclosure or mounted to a backplane.

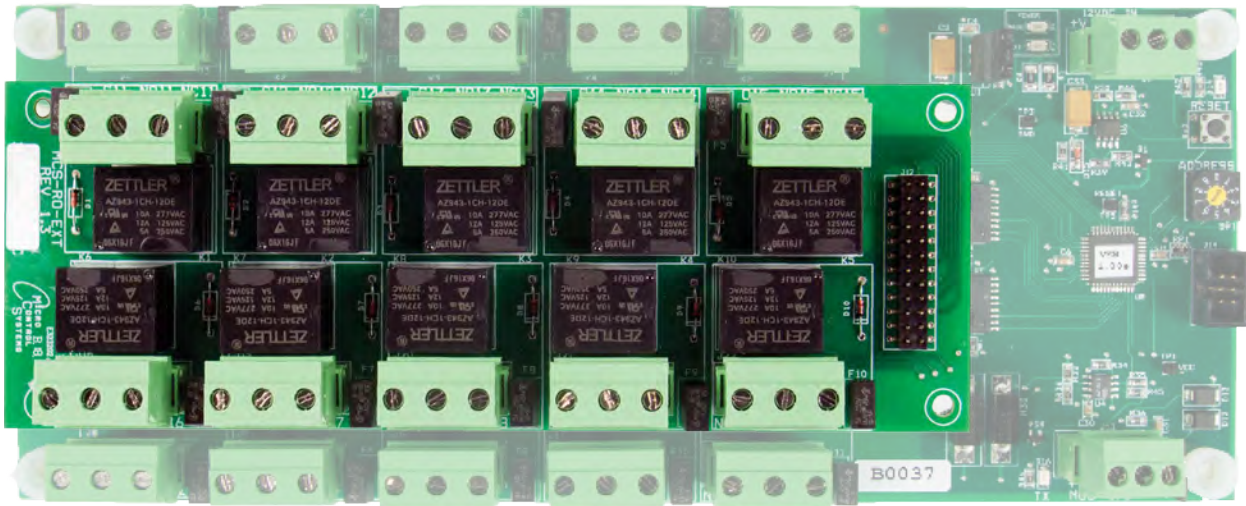

MCS-RO-BASE and MCS-RO-EXT

Dimensions	9.5"l, 4.00"w, 2.50"h
MCS-RO-BASE	Mounts on a backplane using four #6 sheet metal screws
MCS-RO-EXT	Mounts on top of the MCS-RO-BASE by 4 nylon standoffs and a stacker header (included on MCS-RO-BASE)
Operating Temperature	-40°F to +158°F (-40°C to +70°C)
Operating Humidit	0-95% Non-Condensing
Storage Temperature	-40°F to +158°F (-40°C to +70°C)
Microprocessor	Microchip PIC16F883 @ 8mhz
Relay Outputs (RO)	10 outputs 5amps @ 230VAC on bsse - 20 total with MCS-RO-EXT
Printed Circuit Board	Four layer with separate power and ground planes
Input Power (Standard	12VDC input power ±10% @ 77°F (25°C) ambient, 12VA max
MCS-I/O Comm Port	1 @ 38,400 Baud
Power Detection	Automatic power fail reset

3.7. MCS-SI-BASE and MCS-SI-EXT

The MCS-SI-BASE provides a flexible and cost effective way to allow sensor input expansion for MCS MAGNUM-N-12.

Using a Single Output Power Supply the MCS-SI can be used with 115-230 or 24 volt MCS-MAGNUM-N or MicroMag systems.

Using the stackable MCS-SI-EXT you can double the number of inputs and outputs in the same footprint in your enclosure or mounted to a backplane.

MCS-SI-BASE and MCS-SI-EXT

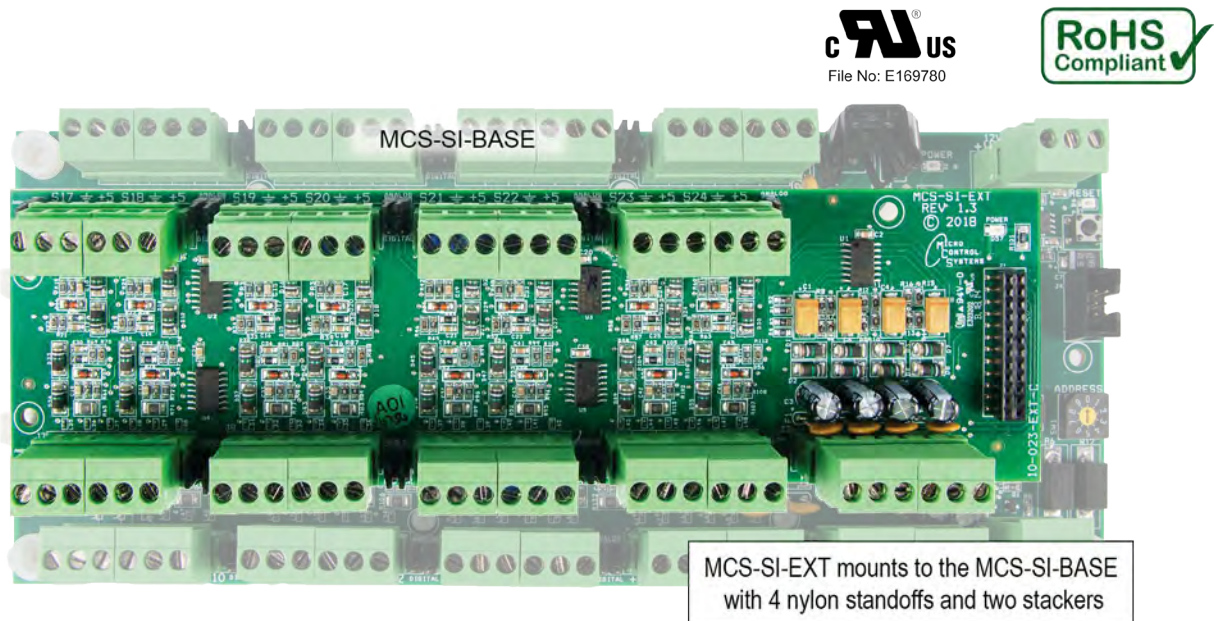

Dimensions	8.7"l, x 2.50"w, x 2.50"h
MCS-SI-BASE	Mounts on a backplane using four #6 sheet metal screws
MCS-SI-EXT	Mounts on top of the MCS-SI-BASE by 4 nylon standoffs and stacker headers (included on MCS-SI-BASE)
Operating Temperature	-40°F to +158°F (-40°C to +70°C)
Operating Humidity	0-95% Non-Condensing
Storage Temperature	-40°F to +158°F (-40°C to +70°C)
Sensor Inputs	16 inputs 0-5vdc on base - 32 total with MCS-SI-EXT
Analog Outputs	8 outputs 0-10vdc on base - 16 total with MCS-SI-EXT
Printed Circuit Board	Four layer with separate power and ground planes
Input Power	Powered by MCS-SI-BASE Power
Power Detection	Automatic Power Fail - Reset on MCS-SI-BASE

Chapter - 4. Network Connection-MCS-485

The next few pages show recommended network setups for communication to your controller using products from MCS.

4.1. MCS 485 Network

The MCS 485 Network can support up to 20 Magnums and their associated I/O boards. Access to this network can be remotely through a 14.4K Baud modem. When using the dialup connection through a modem there is no degradation in the performance of the network.

Each Magnum in the network must be assigned a unique address in the configuration file. This address will be the key in establishing communications with the appropriate Magnum system. It can be viewed or changed from the LCD / key-pad of the unit with Factory authorization.

RS485 transmissions should not exceed 1 mile without a repeater.

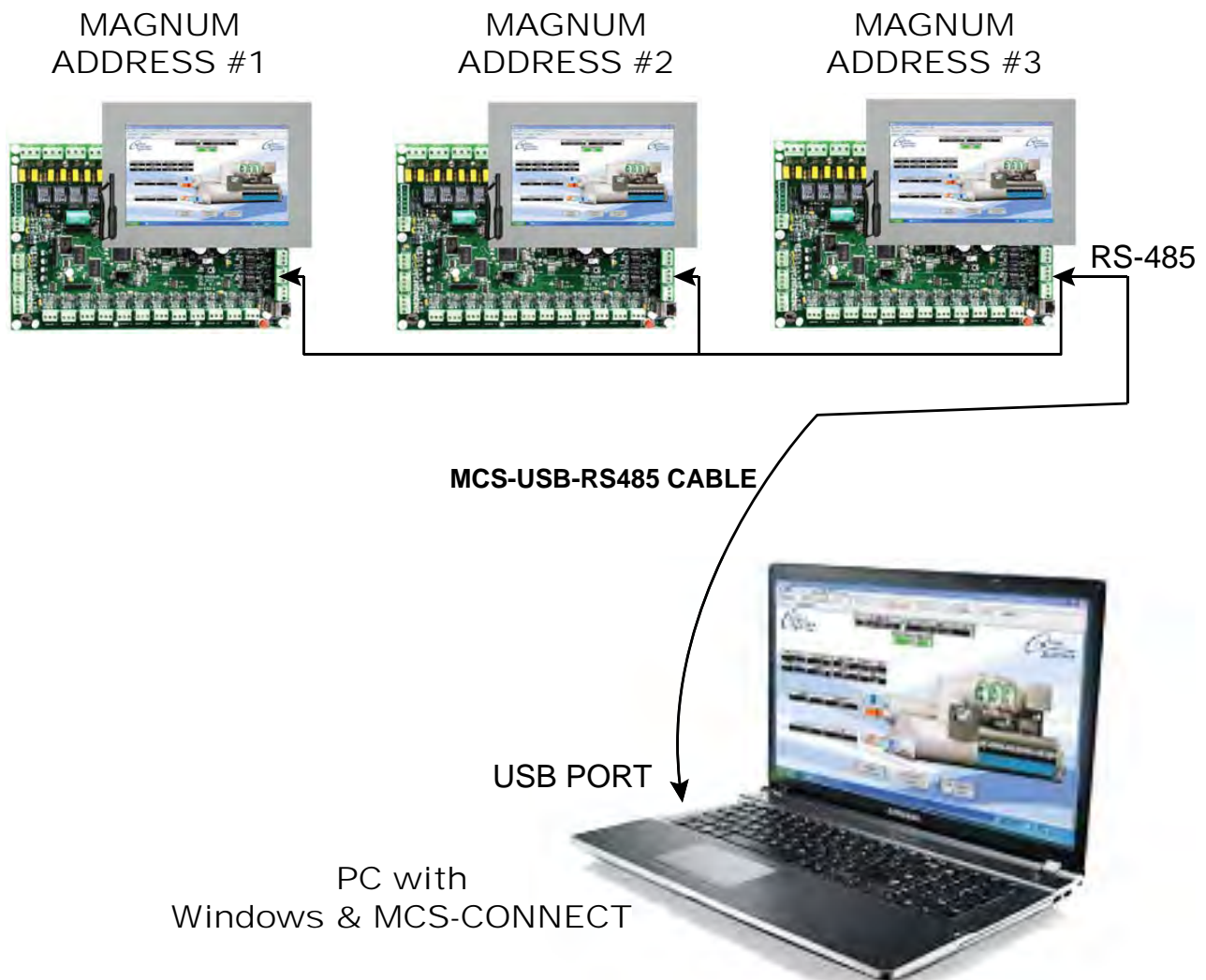

Chapter - 5. Network Connection-Ethernet

5.1. ETHERNET

5.1.1 RJ45 using a Crossover Ethernet Cable

When connecting directly through the 10 MBPS Ethernet port on the Magnum from a PC it is necessary to use a crossover Ethernet cable.

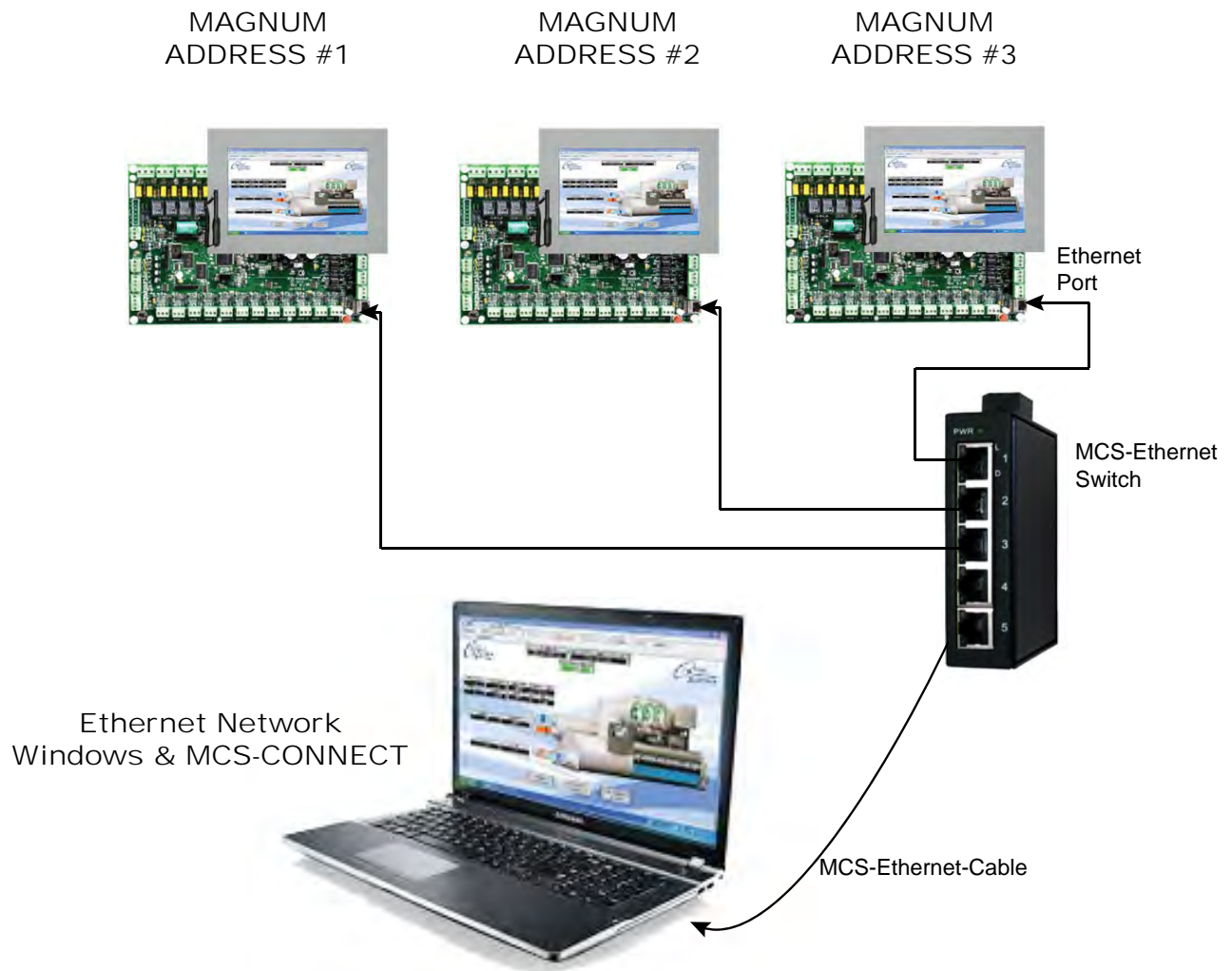

Chapter - 6. Network Connection-Remote

6.1. Remote using Ethernet

When connecting directly through the 10 MBPS Ethernet port on the Magnum from a PC it is necessary to use a crossover Ethernet cable to the MCS-WIRELESS MODEM.

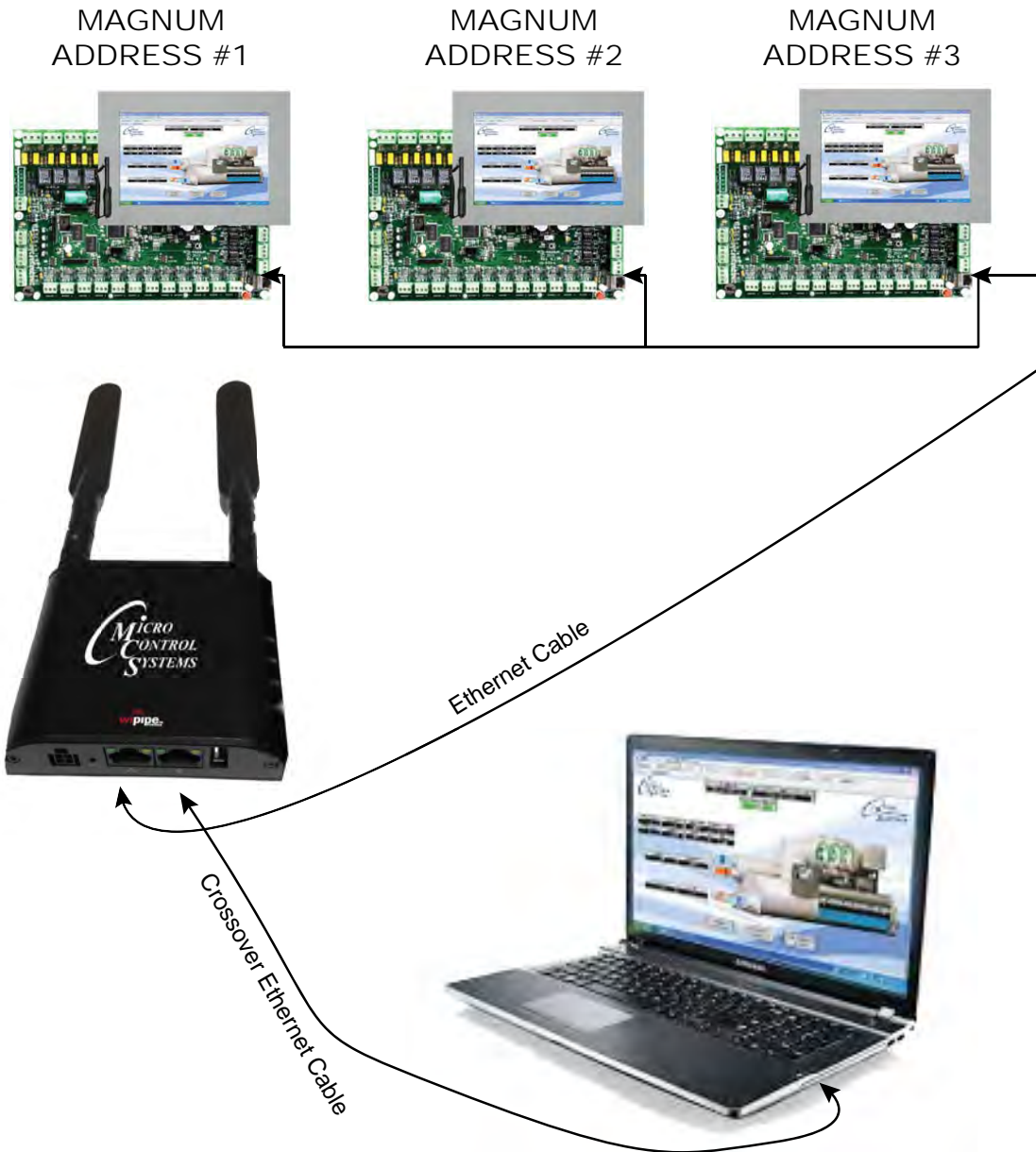

See Label for Actual Setting

MCS-WIRELESS MODEM is shipped from the factory with the IP address configured for you. Instructions on how to setup your PC to communicate with the MCS-WIRELESS MODEM will be included.

Chapter - 7. PC Software for the Magnum

MCS-Config provides the configuration file (.cfg), which includes the input/output points list, Setpoints, circuit information, etc., for all versions of software. This program is designed to assist and make the task of building the configuration file as simple as possible. A manual created in a PDF format is available on our web site: www.MCScontrols.com, or available in other formats upon request.

MCS-Connect provides both local and remote communications to the Magnum independent of software type. Local communications can be either through an RS485 or Ethernet connection. This program displays the status of the controller, and changes can be made to the system with proper authorization. Configuration files can be transmitted to or received from a Magnum unit. The Magnum automatically performs history logging and this program allows the data to be presented in a useful graph form.

7.1. Requirements for PC Software

To install and run the program we suggest the following system requirements:

Minimum System Required to Run Program

- PC with a Pentium-class processor
- Windows 7 or later operating system or
- Linux operating system
- Minimum 1GB of RAM
- Minimum 4GB Drive
- 14.4k baud modem or higher for remote Communications
- 1280 x 800 pixel or higher display

**MCS-CONFIG
SETUP SCREEN**

MAGNUM Setup Screen

Display Units: Deg F / PSI
 Default LCD Display: LARGE
 Default Display Point: []

Max Lockout Resets per Day: 6
 Auth Level Bypass: Supervisor Level
 Lockout Reset SI: Not Used

History Sample Rate (Seconds): 60

Activate Keypad Cursor Quick Move Feature?
 Yes No

Generate Alarm for Network Time Synchronization
 Yes No

Generate Alarm When Configuration is Updated
 Yes No

Display Alarm Character(a) On Keypad LCD Screen
 Yes No

Total Number of RO's: 41
 Total Number of AO's: 10
 Total Number of SI's: 74
 Number of RO Boards: 3
 Number of SI16 boards: 3

Spare ROs: []
 Spare AOs: []
 Spare SIs: []

Type of I/O Boards:
 RO-8 & SI-16 & MCS I/O RO-10 & SI-16-AO4

MCS-Thermostat:
 Yes No

Factory Startup:
 Enable This Feature? Yes No
 Feature Is Active? (Password Entered) Yes No

Run Hour Lockout:
 Enable This Feature? Yes No
 Feature Is Active? (Password Entered) Yes No

Daylight Savings Time:
 Daylight Savings Time Active: Yes No
 Daylight Savings Time DOW: Sunday
 Daylight Savings Time Hour: 2
 Reset to U.S.A Daylight Savings: []

Spring Forward Month: March
 Spring Forward Begin Date: 8
 Spring Forward End Date: 14
 Fall Back Month: November
 Fall Back Begin Date: 1
 Fall Back End Date: 7

RS485 Communication:
 MCS Protocol Address: 1
 Protocol Type: MCS
 Baud Rate: 19200

Ethernet Communication:
 Static IP Dynamic IP
 IP Address: 192 168 2 51
 Subnet Mask: 255 255 255 0
 Default Gateway: 192 168 2 1
 MCS IP Port: 5001
 BACnet Device ID: 181 10 BACnet Port: 47 808

Chapter - 8. Authorization Function

8.1. Authorization Function

The authorization code is a special four-character code that enables access to the Magnum controller.

The code may consist of any valid alpha/numeric characters if the system is being accessed through MCS-Connect, however, the code must be numeric with values between 1 and 8 if it is to be entered through the Keypad/Display. Each Magnum can have up to 10 different authorization codes, with four levels of authorization which provide differing levels of functionality. The authorization code and the associated level cannot be viewed or changed through the Keypad/Display or MCS-Connect, but only when the configuration file is opened in MCS-Config. The authorization codes should be protected and remain confidential, or unauthorized personnel may gain access to the system and perhaps cause irreparable damage.

From the Keypad/Display the following changes can be made based upon the authorization level:

FUNCTION	VIEW	USER	SERVICE	SUPERVISOR	FACTORY	ADMIN
Sensor offsets	NO	NO	YES	YES	YES	YES
Sensor diagnostics	NO	NO	YES	YES	YES	YES
Clear alarm history	NO	NO	NO	NO	NO	YES
Clear point information	NO	NO	NO	NO	NO	YES
Date and time set	NO	YES	YES	YES	YES	YES
Day of week set	NO	YES	YES	YES	YES	YES
Change No Flow Lockout or shut down	NO	NO	NO	NO	YES	YES
Change rotate Yes or No	NO	NO	NO	NO	YES	YES
Change Manual/Auto settings	NO	NO	NO	YES	YES	YES
Change setpoint values	NO	*	*	*	YES	YES
Change operating schedules	NO	YES	YES	YES	YES	YES
Change holiday dates	NO	YES	YES	YES	YES	YES
Lockout Reset	NO	**	**	**	YES	YES
*** Change RS485 network settings	NO	NO	YES	YES	YES	YES
Change Ethernet network settings	NO	NO	YES	YES	YES	YES
Adjust Keypad/Display contrast	YES	YES	YES	YES	YES	YES

* Setpoints may have individual authorization levels; you must have the proper authorization to view or edit them.

**See the Setup screen of the configuration for authorization level(s) that are allowed unlimited resets per day. Authorization levels below 'Auth Level Bypass' are allowed only a limited number of resets. Authorization levels at and above 'Auth Level Bypass' are allowed unlimited lockout resets.

***Firmware Version 17.62M, 'Change RS485 network settings - **SERVICE** or greater.'

To get authorized through the Keypad/Display do the following:

1. Press 'Menu'
2. Using ↑ ↓, →, or ← keys, move cursor to 'Passwords'
3. Press ←key.
4. Enter 4 digit password and press ←

To get authorized through MCS-Connect do the following:

Site Info						
Address	HW Serial #	Cfg Name	Company Name	Unit Model #	Unit Serial #	Installed Date
192.168.10.4 (2)	001088	OFFICE AHU	MicroCtrlSystem	Cool/Heat/OA		11/13/2012
192.168.10.4 (1)	008038	HEATPUMP	MCS	LL 125 TON		05/05/2015
192.168.10.4 (6)	011492	PLANT AHU3	MCS	AAON	JB-HVAC 14.02F	01/07/2014
192.168.10.4 (5)	010462	TR ROOM	MicroCtrlSystem	Cool/Heat/OA		11/13/2012
192.168.10.4 (7)	012938	PLANT AHU1	MCS	AAON	JB-HVAC 14.05U	01/07/2014
192.168.10.4 (3)	002210	DOWN VAVS	MicroCtrlSystem	12,14,15,16	BCL HVAC 09.10L	06/01/2012
192.168.10.4 (4)	001624	UP VAVS	MicroCtrlSystem	8,10,11,13A,13B	JAT HVAC 09.10Q	08/03/2012
192.168.10.4 (11)	013036	STI	MicroCtrlSystem	Cool/Heat/OA		06/04/2014

1. Click **View Only** on desired Magnum in the Site Information screen.
2. Click button.
3. Enter the 4 digit code into the pop-up box and click ok (or press the enter key).
4. Depending on the authorization level, the button will change to one of the following displays, indicating if the code was accepted or not.



Chapter - 9. Standard Control Options

The following options are specified in the MCS-Config program when building the configuration. These options are used to personalize the system to meet the individual control requirements.

9.1. General Options

- Control method can be based upon the control zone strategy or upon a voltage input that indicates the number of stages to be on.
- The control temperature can specify either the return or leaving sensor.
- Specify if the anti recycle timer should start when the compressor is turned on or turned off. (All circuits)
- Number of circuits, maximum of eight.
- Number of evaporators, maximum of six per compressor.
- Alarm RO, this point will be turned on whenever an alarm is generated.
- REFR OK, Turned off when in alarm.
- Specify auto rotation for circuits.

9.2. Variable Capacity Control Method

9.2.1 Screw Compressor with slide piston

This option is specified in MCS-Config by selecting the compressor type in the Compressor Information Panel under the MAGNUM screen.

As stated in the previous section, the control strategy is designed to modulate the system capacity to maintain the control sensor reading within the specified control zone. The system capacity will be based upon the number of compressors that are Wanted On. When the first, or an additional compressor, is turned on the system capacity will be set to the calculated value. For the first compressor this will be the value of Setpoint #31 "MIN FLA %". When additional compressors are brought on, their capacity is calculated to provide the same percentage of capacity prior to the change. The Magnum will adjust the required capacity between the calculated and the maximum value as specified in Setpoint #30 "MAX FLA %". All compressors that are on will be adjusted together to meet the system capacity.

When the maximum capacity value of the currently operating compressors has been reached, an additional compressor, if available, will be Wanted On. The number of compressors Wanted On will be increased by one and the system capacity will be set to the calculated value to maintain the same capacity as before the change and the sequence will begin again. Once all available compressors are on, their maximum will be 100% regardless of the value in Setpoint #30 "MAX FLA %".

When the minimum calculated value has been reached, a compressor will be turned off. This will occur when the reduced number of compressors can achieve the same capacity at 90%. The number of compressors Wanted On will be decreased by one and the system capacity will be set to 90% and the sequence will begin again.

The compressor slide control is based upon the amps drawn by that compressor. For example, if Setpoint #31 "MIN FLA %" is set to 30%, that means 30% of the calculated full load amperage for that compressor. Screw compressors with slide pistons that are turned on can either be loading (load solenoids are pulsed), unloading (unload solenoids are pulsed), or in a hold state (no action is taken). The state of each compressor reflects this action.

9.2.1.1. Force Digital Compressor Speed

Firmware Ver Refrig 17.26E7 (or greater) - This new feature allows the config to define a separator min allowed speed for compressor. This feature is design to be used with tandem compressors. So when only the vfd compressor is running the user can define a higher min speed than the capacity control logic allows. This feature is designed to force the compressor to run at fast speed to insure proper oil return.

In order to use this new logic you must make setpoint #31 “Min Spd%” a “TARGET” type and put in the Low Zone column the min speed value you want for running the digital compressor when only the digital compressor is running on the suction group(see below).

#	Name	Value	Min	Max	Adjust Value	Time (SEC)	Max Time Allowed (SEC)	Lockout Delay (HRS)	Safety Down Time(MIN)	Active or Non-Active	Select Value: # decimals & print char	Level Of Auth. To Display	Type of Setpoint	Comments	SEC to Ignore Safety	Window to Ext. Safety Time(SEC)	Safety Time Extension (SEC)	High Zone	Low Zone
29	ROC INTERVAL	60	20	60	5	0	0	0	0	Non-Active	...SECONDS	View Only	Setpoint	...	---	---	---	---	---
30	MAX SPD %	100	50	110	1	0	0	0	0	Active	...HUMD or %	View Only	Setpoint	...	---	---	---	---	---
31	MIN SPD %	10	10	80	1	0	0	0	0	Active	...HUMD or %	View Only	Target	...	---	---	0	30	
32	MAX ADJUST %	5	5	10	1	0	0	0	0	Active	...HUMD or %	View Only	Setpoint	...	---	---	---	---	
33	MIN ADJUST %	2	1	5	1	0	0	0	0	Active	...HUMD or %	View Only	Setpoint	...	---	---	---	---	
34	ADJ SENSIT	1	1	10	1	0	0	0	0	Active	...DIGITAL/SW	View Only	Setpoint	...	---	---	---	---	

9.2.2 Compressor with a Variable Frequency Drive (VFD)

This option is specified in MCS-Config by selecting the Analog Output for the VFD in the “Compr Speed or Modulate Hot Gas AO” cell in the Circuit Base screen.

Select Output and Sensor Inputs per circuit										
Circuit # (reset button)	Alarm Relay	Comp Proof	Compr Speed or Modulate Hot Gas AO	Compressor speed fault	Slide Closed Indicator	Pump Down	EXV Output	Flow	Circuit Pump/Valve	
1	Not Used	Not Used	COMP1 SPD	Not Used	Not Used	DISABLE 1	Not Used	Not Used	Not Used	

The Magnum will control the compressor speed in the same matter as the compressor slide. The same Setpoints will be used. This allows a fixed staged compressor’s capacity to be varied. See previous section for Setpoints associated with variable capacity control logic.

9.2.3 Example of a system with 3 variable Step Compressors

(Example below assumes compressor 1 is the current lead compressor.)

STAGE 1

Compressor 1’s startup procedure has begun. Once on, the capacity will be adjusted from the minimum to the maximum. All other compressors will be off. The steps Wanted On / Actual On will be 1 / 1.

STAGE 2

Compressor 2’s startup procedure has begun. Once on, the system capacity will be changed to the calculated % and compressor 1 will be unloaded until it matches the calculated system capacity. Both compressors will be varied from the calculated to the maximum. All other compressors will be off. The steps Wanted On / Actual On will be 2 / 2. If the system capacity has been reduced to 45%, or the calculated % (whichever is larger) and less capacity is needed, a compressor will be turned off and the system capacity will be set to the 90% or the maximum and the system will return to Stage 1.

STAGE 3

Compressor 3’s startup procedure has begun. Once on, the system capacity will be changed to the calculated % and compressors 1 and 2 will be unloaded until they equal the required capacity. All compressors will be varied from the calculated to 100%. The steps Wanted On / Actual On will be 3 / 3. If the system capacity has been reduced to 60%, and less capacity is needed, a compressor will be turned off and the system capacity will be set 90% and the system will return to Stage 2.

9.2.4 Compressor Types

The compressor type is selected from a drop down list in the Compressor Information panel on the MAGNUM Refrig screen.

- Type of compressors supported:
 - Reciprocating with oil,
 - Reciprocating with out oil,

- Screw with oil,
 - Hitachi Screw,
 - Hartford Screw Comp,
 - Carlyle Screw
 - Centrifugal
 - TurboCor
 - Scroll or VFD Comp,
 - Bitzer Screw CompHartford Screw
 - Hall 85/95 Ton Screw
 - Hanbell Screw
 - Mitsubishi
 - Trane Screw
- Three compressor steps can be supported. Compressor plus two additional steps of unloaders. Note, compressor safeties relate to a circuit. If multiple compressors are on a circuit and a safety trips all compressor on that circuit will be turned off. If hot gas bypass refer to Hot Gas Bypass Option.
 - Specify that part winding, two RO points will be used with fixed step compressors, the first RO will be turned on with the second RO being turn on the number of seconds later that is specified in set point #62. (By circuit) If not part winding, only allocate one RO point for the compressor.
 - Pump down, the compressor will be pumped down only when the compressor is being turned off. Note, when the compressor is started the liquid line solenoid is not opened until the suction pressure reaches the value that is contained in the pump down set point. A liquid line solenoid is required. (All circuits)

9.2.5 Condenser Options

- Number of condensing stages.
- Type of condenser:
 - None,
 - RO Step Common (all compressors monitored for discharge pressure),
 - RO Step Combined, circuits 1 & 2 and circuits 3 & 4 will share a condenser (compressor on related circuits monitored for discharge pressure),
 - All of the RO Step type condenser can have a variable speed fan per circuit,
 - Modulating Common. This is usually used to control a water condenser with a value that will be modulated depending on the rate of change of the discharge pressure
 - RO Step Shared, selected circuits will share a condenser (compressor on related circuits monitored for discharge pressure),

9.3. Target Reset (only if temperature control)

This option is only available if the control on zone (temperature) has been selected.

Target Reset is a 0 to 5 volts dc sensor input; Display Type is TRGTRST, to the Magnum microprocessor.

The Target Reset follows the following rules using set point #21, MAX TRG RESET:

1. If the input is 2.5 volts dc the Target Reset is zero.
2. At 0 volts dc the Target Reset is a negative value equal to the set point value.
3. At 5.00 volts dc the Target Reset is a positive value equal to the value in the set point.
4. For values in between 0 – 2.5 and 2.5 – 5.0 the Target Reset is a plus or minus value which is proportional to the sensor input voltage.

9.4. Oil Differential Calculation

For all other software the calculation is OIL PRESSURE minus SUCTION PRESSURE. This provides the flexibility of using oil pressure if available or if not, discharge pressure can be used in place of the oil pressure. This is set up in the circuit information section of MCS-Config by pointing the oil pressure sensor to the discharge pressure

9.5. On/Off Switches

- The following digital input switches can be associated with the system, their action will affect the chiller package or an individual circuit, then action will only affect that circuit:
- Flow switch, if off the system has lost flow. The system wills either lock out, if NO FLOW set point is active, or shut down, if NO FLOW set point is inactive.

- Pump down switch, if on and the compressor is off, will not start the compressor. If the compressor is on, the system moves to the pump down state to begin the process of turning off the compressor(s) in normal steps.
- Run/Stop, if off the system will not run. This is usually wired to a RUN/STOP switch that is manually positioned. If the system is running, the system moves all circuits (compressor) to off in normal steps.
- Network Run/Stop, if off the system will not run. This input is provided by another system that resides on the network. It functions in the same matter as the Run/Stop switch.
- Emergency Stop switch, if on, the system will be shut down immediately and will remain disabled until the switch is off.

9.6. Low Suction Unloading & Holding

Set point #168, UNLOAD DELAY, will delay the unloading.

This option is activated when the set point #70, LO SUCT UNLD, is active. The purpose of this option is to take corrective action prior to a safety being tripped. When the suction pressure is below the value calculated by adding the value of this set point to the value of the LOW SUCTION set point for the time specified, the system will turn on the WARNING relay output if specified in the MCS-Config and take the following action:

- For a fixed step compressor, the system will turn off one step of capacity associated with that compressor until that circuit is in an UNLOADED state, which all steps except one are unloaded. The circuit (compressor) state will be LO SUCT HOLD. The circuit will remain in that state until the capacity control indicates that another step is to be unloaded or if after 5 minutes the suction pressure has turned to normal.
- For an infinite step compressor, the system will begin unloading that compressor until the suction pressure rises above the calculated value. During this time the circuit (compressor) state is LO SUCT UNLOAD. Once this pressure has been reached, the circuit (compressor) state will be LO SUCT HOLD. The circuit will remain in that state until the capacity control indicates that less capacity is needed or if after 5 minutes the suction pressure has turned to normal.

Normal pressure is the value calculated by adding the value of the LO SUCT RELD set point #71 to the value of the LOW SUCTION set point #69.

9.7. High Discharge Pressure Unloading & Holding

Set point #168, UNLOAD DELAY, will delay the unloading.

This option is activated when the set point #74, HI DISC UNLD, is active. The purpose of this option is to take corrective action prior to a safety being tripped. When the discharge pressure is above the value calculated by subtracting the value of this set point from the value of the HI DISCH PSI set point for the time specified, the system will turn on the WARNING relay output if specified in the MCS-Config and take the following action:

- For a fixed step compressor, the system will turn off one step of capacity associated with that compressor until that circuit is in an UNLOADED state, that is all steps except one are unloaded. The circuit (compressor) state will be HI DISC HOLD. The circuit will remain in that state until the capacity control indicates that another step is to be unloaded or if after 5 minutes the discharge pressure has turned to normal.
- For an infinite step compressor, the system will begin unloading that compressor until the discharge pressure drops below the calculated value. During this time the circuit (compressor) state is HI DISC UNLOAD. Once this pressure has been reached, the circuit (compressor) state will be HI DISC HOLD. The circuit will remain in that state until the capacity control indicates that less capacity is needed or if after 5 minutes the discharge pressure has turned to normal.

Normal pressure is the value calculated by subtracting the value of the HI DISC RELD set point #75 from the value of the HI DISC PSI set point #73.

9.8. High Discharge Temperature Unloading & Holding

Set point #168, UNLOAD DELAY, will delay the unloading.

This option is activated when the set point #80, HI DISC UNLD, is active. The purpose of this option is to take corrective action prior to a safety being tripped. When the discharge temperature is above the value calculated by subtracting the value of this set point from the value of the HI DISCH TMP set point for the time specified, the system will turn on the WARNING relay output if specified in the MCS-Config and take the following action:

- For a fixed step compressor, the system will turn off one step of capacity associated with that compressor until that circuit is in an UNLOADED state, that is all steps except one are unloaded. The circuit (compressor) state will be HI DISC HOLD. The circuit will remain in that state until the capacity control indicates that another step is to be unloaded or if after 5 minutes the discharge temperature has turned to normal.
- For an infinite step compressor, the system will begin unloading that compressor until the discharge temperature drops below the calculated value. During this time the circuit (compressor) state is HI DISC UNLOAD. Once this temperature has been reached, the circuit (compressor) state will be HI DISC HOLD. The circuit will remain in that state until the capacity control indicates that less capacity is needed or if after 5 minutes the discharge temperature has turned to normal.

Normal pressure is the value calculated by subtracting the value of the DIS TMPRELD set point #81 from the value of the HI DISC TMP set point #79.

9.9. High Ampere Unloading & Holding

Set point #168, UNLOAD DELAY, will delay the unloading.

This option is activated when the set point #67, HI AMPS %, is active. The purpose of this option is to take corrective action prior to a safety being tripped. When the amp draw is within one-half of the calculated HI AMP safety value, the system will turn on the WARNING relay output if specified in the MCS-Config and take the following action:

- For a fixed step compressor, the system will turn off one step of capacity associated with that compressor until that circuit is in an UNLOADED state, that all steps except one are unloaded. The circuit (compressor) state will be HI AMP HOLD. The circuit will remain in that state until the capacity control indicates that another step is to be unloaded or if after 5 minutes the amp draw has turned to normal.

9.10. Control Power Relay –No Stop

This option provides the capability of interrupting the power supply to the compressors in the system. A relay output, referred to as the control relay, must be wired so that when it is off no power reaches the compressors. This is a safety measure that will insure that the compressors are off then the system calls for them to be off. The relay output must be indicated in the MCS-Config program and set point #97, NO STOP, must be active. The system will continually monitor the amp draw of compressors that the system has in an off state. The system will calculate the minimum amp draw by multiplying the FLA for that compressor times the percentage value in the NO STOP set point. If the amp draw is greater than this value for the time specified; the system will turn the control relay off, generate a NO STOP alarm and place the system in a lockout state. This provides an additional level of protection.

9.11. Part Wind or Star Delta Starter

Either a part winding or star delta type of compressor starter is supported. This option is specified in the MCS-Config program and will require two successive relay output points. When this option is specified, set point #65, STARTER DLAY, must contain the delay in seconds before the second relay output is turned on. This delay is normally 1 second for part winding or 5 seconds for a star delta starter. With this option, when a compressor is to be turned on, the first relay output is turned on and the system will wait the time specified in set point #65 before the second relay output is turned on.

9.12. English or Metric sensor readings

The system supports English, Metric, or a combination sensor readings, this is specified in the MCS-Config program. All sensor values and all software-coded offsets are automatically converted into the option selected and displayed with the appropriate character. The following table contains the display character:

NOTE: Set point values are NOT automatically adjusted. Their values must be set up in MCS-Config to reflect either English or Metric values. Their display character will be automatically adjusted.

SENSOR READING	ENGLISH CHARACTER	METRIC CHARACTER	METRIC CHARACTER
Temperature	F	C	C
Pressure – Gage Reading	P	B	P
Pressure – Absolute Reading	p	b	p
Humidity	%	%	%
Digital or Switch			
Amp or CT	A	A	A
Voltage	V	V	V
Refrigeration Level	%	%	%

9.13. Compressor Auto Rotation

The auto rotation option is selected by setting the value in set point #92, LEAD COMP to zero. If this value is not zero, it will contain the number of the lead circuit (compressor) and auto rotation is disabled. Note this set point can be manually changed to force a different compressor as the lead compressor or to enable auto rotation.

When this option is enabled, the system will rotate the compressors based upon the value in set point # 93.

Setpoint Information Screen													
#	Name	Value	Min	Max	Adjust Value	Time (SEC)	Max Time Allowed (SEC)	Lockout Delay (HRS)	Safety Down Time(MIN)	Active or Non-Active	Select Value: # decimals & print char	Level Of Auth. To Display	Type of Setpoint
92	LEAD COMP	0	0	2	1	1	1	0	0	Active	... DIGITAL /SW	Superviso	Setpoint
93	CMP ROTATION	0	0	30	1	0	0	0	0	Active	... DAYS	Superviso	Setpoint

CMP ROTATION

If the value set point #93 is zero, rotation will occur with every complete capacity cycle and the next compressor will be selected as the lead compressor.

92	LEAD COMP	Enables the user to specify the lead compressor. The value of this setpoint will indicate the lead compressor. If zero, then auto rotation is enabled. If the 'Time (sec)' field is non-zero the compressor with the least amount of run time will become the lead compressor upon rotation.
93	COMP ROTATION	Specifies the number of days between rotations (setpoint #92 must be set to zero to enable auto rotation). If zero, then rotation will occur with every cycle.

If the value set point # 93 is zero, rotation will occur with every complete capacity cycle and the next compressor will be selected as the lead compressor.

Else, the value is the number of days between rotations. At midnight the system will check if it is time to rotate compressors. If yes, the system will check the run hours on each compressor and select the one with the least amount of run hours to be the lead compressor.

If set point # 93 is set up as an ALARM type of set point, a compressor rotation message will be generated each time a compressor is rotated.

9.14. Expanded Compressor Rotation to Check for Maximum Run Time

In the Compressor Information panel of the Magnum HVAC screen in MCS-Config, there is a check box to select how compressors are to be rotated, based either on Run Time or First On/First Off.

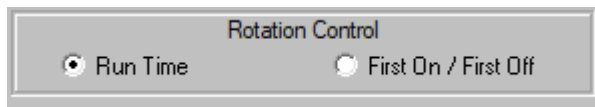

9.15. Run Hour Lockout

In MCS CONFIG, in the Setup screen, select the option Run Hour Lockout Required. If enabled, then enter the number compressor run hours that must pass before the run hour lockout is triggered.

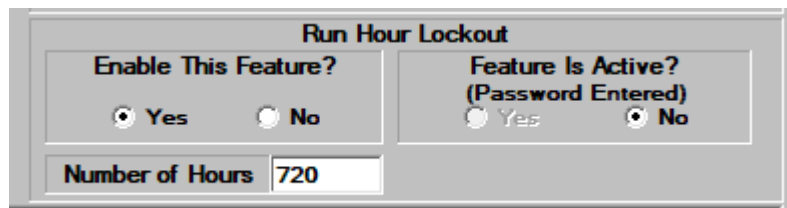

Run Hour Lockout- At midnight if any compressor has reached a set number of run hours, the unit will be disabled until an authorized service call is performed.

Function 2: (Compressor lockout based on run time hours)

If this option has been enabled, at midnight if any single compressor exceeds the number of run hours specified, the system will disable all compressors (circuits) and change the unit state to MAXIMUM RUN TIME. This test will only be made a midnight when new day logic is being executed. In this state the Magnum will not enable normal operations and the only screen that will be available is the Passwords. If the Magnum is reset the chiller state will be MAXIMUM RUN TIME not UNIT IN POWER UP. Once the system state is MAXIMUM RUN TIME the system can be accessed from MCS-Connect but the system will not accept changes to the Relay Output states.

9.16. Compressor Anti-Cycle Logic

When a compressor is to be turned off, the Magnum software will make a calculation to determine the amount of time that the compressor will remain in an anti-cycle state. This calculation is based upon how long the compressor has been on and setpoints #59 "ACYC OFF->ON" and #60 "ACYC ON->ON".

If the value of setpoint #60 minus the amount of time that the compressor has been on is greater than the value in setpoint #59, the compressor will remain in the anti-cycle state for the period of time specified in setpoint #60. Else the anti-cycle timer will be set to the value in setpoint #59.

For example:

#59 (ANTI-CYC OFF) = 300 seconds

#60 (ANTI-CYC ON) = 600 seconds

If the compressor had been running for 3 minutes (180 seconds)

$600 - 180 = 420$ this is greater than setpoint #59; therefore, the anti-cycle timer will be set to 600 seconds, the value of setpoint #60.

If the compressor had been running for 12 minutes (720 seconds)

$600 - 720 = -120$ this is less than setpoint #59; therefore, the anti-cycle timer will be set to 300 seconds, the value of setpoint #59.

If the controller loses power, the length of time that the system was down will be taken into consideration when determining whether the compressor should be in an anti-cycle state and for how long.

9.17. Warning & Alarm Relay Outputs

Warning Relay Output will be turned on whenever the system generates a warning type of message. These messages are:

- LOW REFR TEMP UNLOAD
- LOW SUCT PSI UNLOAD
- HIGH DISC TEMP UNLOAD
- LOW SUCT RELOAD
- LOW DISC RELOAD
- CIRCUIT IS IN A SAFETY STATE

The system will continue to run and no safeties have been tripped.

Warning Relay Output will also be turned on whenever a circuit is placed in a safety state.

Alarm Relay Output will be turned off whenever the system generates an alarm type of message. This indicates that a safety or lockout condition has occurred.

9.18. Operating Schedules

Two operating schedules per each day of the week and 8 holidays are supported. Each schedule contains a start and end time, if the time and day of the system is within these limits the schedule is true and the system will be allowed to run. If not, the system will be off due to schedule.

9.19. **Modification to adjust approach values**

New set point #152 is required. To activate the adjustment to all approach set points (119, 122, 125 & 127) this set point must be active. Its value is the maximum adjustment that will be made to the approach set points.

The adjustment will be made proportional to the positioning of the wanted on of the slide. If the slide is mid-point between its minimal and maximum, then the adjustment will be one half of the value in set point #89.

The following table is the result of testing this change: Set point #152 = 10.0. Range is 60 (100.0 – 40.0)

	Adjusted Values	Adjusted Values	Adjusted Values	Adjusted Values	Adjusted Values	Adjusted Values
Voltage		0.3	.7	1.9	2.1	5.0
% Wanted		40	50	83	89	100
% Of range		0	16	71	81	100
Set PT #119	19.0	19.0	17.7	11.8	10.9	9.0
Set PT #122	20.0	20.0	18.2	12.8	11.9	10.0
Set PT #125	14.0	14.0	12.2	6.8	5.9	4.0
Set PT #127	19.0	19.0	17.2	11.8	10.9	9.0

Chapter - 10. Magnum Control Zone

10.1. Control Method Option

This option is selected in the MCS configuration program:

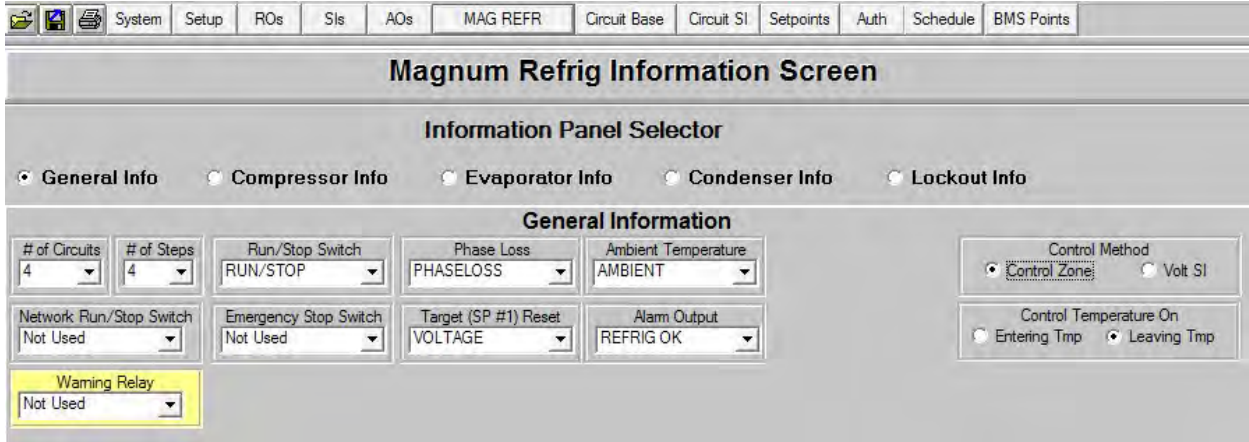

This control strategy is based upon developing a control zone and then to step the compressor(s) through their stages to maintain the control sensor reading within this zone. To accomplish this, the system will constantly monitor the control value, its rate of change and position in relationship to the control zone and make adjustments accordingly.

The strategy of a fixed step system, reciprocating compressor, and a variable (slide) step system, screw compressor or a reciprocating compressor with an inverter, are slightly different. The variable step system allows for infinite variations of capacity while the fixed step system does not.

This option is active in all software and is specified in the MCS-Config program.

10.2. Common Definitions

10.2.1 Target

The control target is specified in set point #1. This will be the base of developing the control zone.

10.2.2 Control Zone

The control zone is developed by adding the set points for the control target (set point #1) and the dead band + (set point #2) to obtain the upper limit. The lower limit is obtained by subtracting the dead band - (set point #3) set point from the control target (set point #1).

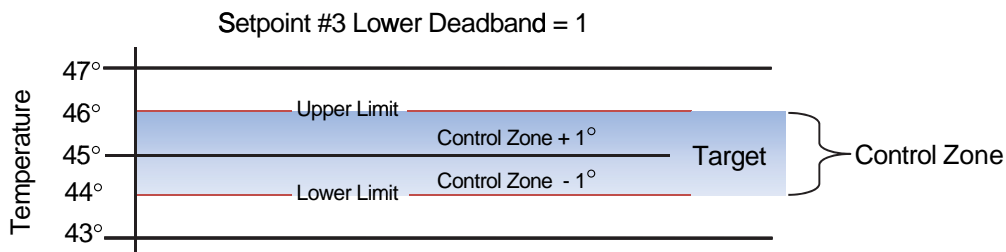

Once the control zone has been established, the system will attempt to keep the control sensor reading with in this range.

10.2.3 Control Sensor

This is the sensor that has been specified in the MCS-Config program as providing the control value reading. It will normally be either the entering or leaving temperature or the suction pressure. The set points must be adjusted according to the type of control measurement selected.

10.2.4 Control Input Rate of Change

The Rate of Change is how rapidly the control value changes over a period of time. If the control value is increasing the rate will be positive, if decreasing the rate will be a negative value. How quickly the input is changing, its direction and its distance from the control zone will all be used to determine how the Magnum will respond.

10.2.5 Step Delay and Sensitivity

The system will not attempt to take action until the Step Delay counts down to zero. Set point 26 contains the initial value. The speed that the counter will decrement by is based upon the rate of change and the sensitivity that has been specified in Set point #26. The purpose of the sensitivity value is to limit how quickly the Magnum reacts to changes indicated by the control sensor. The lower the value of the Set point,, the faster the Magnum will react to changes of the control sensor.

Chapter - 11. Magnum Voltage SI Control Method

This option is selected in the MCS Configuration program.

The screenshot shows the 'Magnum Refrig Information Screen' with the 'General Information' panel selected. The 'Information Panel Selector' at the top has radio buttons for 'General Info' (selected), 'Compressor Info', 'Evaporator Info', 'Condenser Info', and 'Lockout Info'. The 'General Information' section contains several dropdown menus and checkboxes:

- # of Compressors: 4
- # of Steps: 4
- Run/Stop Switch: RUN/STOP
- Phase Loss: PHASELOSS
- Ambient Temperature: AMBIENT
- Network Run/Stop Switch: Not Used
- Emergency Stop Switch: Not Used
- Step Voltage SI: VOLTAGE
- Alarm Output: REFR OK
- Control Temperature On: Entering Tmp, Leaving Tmp
- Warning Relay: Not Used
- Unit Status Relay: Not Used
- Control Method: Control Zone, Volt SI

An alternate control strategy is based on a variable voltage input to the Magnum board. This control strategy is based upon developing a series of cut in (turn on) and cut out (turn off) values for each capacity stage (step) in the system. When a cut in value has been reached or exceeded and the delay time between stages (steps) has been satisfied, the Magnum will turn on the next stage (step). Conversely, when a cut out value has been reached and the delay time between stages (steps) has been satisfied, the Magnum will turn off a stage (step) that was turned on.

11.1. Number of steps supported:

REFR software supports 24 stages of capacity, set points 205 through 229 are used with this option.

11.2. Common Definitions

11.2.1 Targets, Stage Cut In Values

The control targets, stage cut in values, for up to 24 steps of capacity are specified in set points 206 through 229.

11.2.2 Stage Cut Out Values

The stage cut out values for each step of capacity is calculated by subtracting set point 205 from the individual step cut in value.

11.2.2.1. Step Delay

The step delay is contained in set point 26. This is the minimum time between changes in capacity.

11.2.2.2. Controlling Sensor

This is the sensor that has been specified in the MCS-Config program as providing the control value. It must be a voltage sensor type. The voltage value is provided by an external system.

Chapter - 12. REFR Defrost

12.1. Defrost cycle initialization:

A defrost cycle can be initiated in the following ways:

1. By the approach set point temperature and time being satisfied,
2. If the compressor accumulated run time exceeding the value in setpoint #145 (or setpoints #120, #123, #126 high zone).
3. By the Manual Defrost Switch being on. Manual Defrost Switch if it exists must be setup in the Circuits SI grid under the MAG REFR button.

Select Temperature, Refrigeration and Oil Indicators for Circuits									
Circuit # (reset button)	Oil Seal Temp	Oil Float	Leaving Temp	Refrigerant Temp	Refrig Level	Manual Defrost Switch	Evap Suct Temp	Evap Suct PSI	
1	Not Used	Not Used	Not Used	Not Used	Not Used	ManDefrost	COIL TMP 1	EVAP PSI 1	
2	Not Used	Not Used	Not Used	Not Used	Not Used	ManDefrost	COIL TMP 2	EVAP PSI 2	

The system evaporator temperature must be set up in MCS-Config under the MAG REFR button in the Evaporator Information section, cell EVAP Temp SI:

4. **Setpoint #118 'TARGET TYPE'** - if setpoint #118 is configured as a "Target" type, then setpoint #118 high zone column is used as the ambient disable temperature for rotating coil defrost. Otherwise if setpoint #118 is not configured at "Target" type the old logic of using setpoint #118 value as the ambient disable point for rotating coil defrost is used.

#	Name ↓	Value	Min	Max	Adjust Value	Time (SEC)	Max Time Allowed (SEC)	Lockout Delay (HRS)	Safety Down Time(MIN)	Active or Non-Active	Select Value: # decimals & print char	Level Of Auth. To Display	Type of Setpoint	Comments	SEC to Ignore Safety	Window to Ext. Safety Time(SEC)	Safety Time Extension (SEC)	High Zone	Low Zone	Night Setback
118	HtGasHiTemp	45	10	70	1	0	0	0	0	Active	TEMP	View Only	Target					48	43	0
119	HtGasHiAppr	30	2	50	0.1	0	0	0	0	Active	TEMP	View Only	Setpoint							
120	HtGasHiTime	4	1	60	1	0	0	0	0	Active	TEMP	View Only	Setpoint							
121	HtGasMedTemp	40	10	70	1	0	0	0	0	Active	TEMP	View Only	Setpoint							
122	HtGasMedAppr	18	2	50	0.1	0	0	0	0	Active	TEMP	View Only	Setpoint							
123	HtGasMedTime	30	1	60	1	0	0	0	0	Active	MINUTES	View Only	Setpoint							
124	HtGasLowTemp	37	10	70	1	0	0	0	0	Active	TEMP	View Only	Setpoint							
125	HtGasLowAppr	17	2	50	0.1	0	0	0	0	Active	TEMP	View Only	Setpoint							
126	HtGasLowTime	20	1	60	1	0	0	0	0	Active	MINUTES	View Only	Setpoint							

5. **Set the manual defrost time delay based on the enter temp, high return temp less defrost time required.** If setpoint #120 is setup as "Target" type then manual defrost time delay is based on the enter temp compared to setpoint #118, 121, and 124 and uses the values in the high zone column from setpoint #120, 123, or 126 as the defrost time delay.

Setpoint Information Screen																				
#	Name ↓	Value	Min	Max	Adjust Value	Time (SEC)	Max Time Allowed (SEC)	Lockout Delay (HRS)	Safety Down Time(MIN)	Active or Non-Active	Select Value: # decimals & print char	Level Of Auth. To Display	Type of Setpoint	Comments	SEC to Ignore Safety	Window to Ext. Safety Time(SEC)	Safety Time Extension (SEC)	High Zone	Low Zone	Night Setback
118	HtGasHiTemp	45	10	70	1	0	0		0	Active	TEMP	View Only	Setpoint							
119	HtGasHiAppr	30	2	50	0.1	0	0		0	Active	TEMP	View Only	Setpoint							
120	HtGasHiTime	4	1	60	1	0	0		0	Active	TEMP	View Only	Target					4	3	0

12.2. Approach type setup

If the system is in dehumidification mode, then the approach set up will be based upon the dehumidify values.

Approach Temperature = set point #127

Defrost Duration = set point #128

When in dehumidification, if the approach value satisfies the approach setpoints, the logic will turn off LLS #1 and Turn on LLS #2. There, the logic will monitor the approach for the 2nd LLS. Once the 2nd LLS's approach value meets the defrost setpoint requirements, a defrost cycle will be initiated.

If not in dehumidification mode, the defrost approach temperature and defrost duration is established by comparing the system evaporator temperature to set points #118, #121 and #124.

If the system evaporator temperature input sensor is greater than #121, DEF MED TEMP, then the approach set up will be based upon the high temperature values.

Approach Temperature = set point #119

Defrost Duration = set point #120

If not in dehumidification mode, the defrost approach temperature and defrost duration is established by comparing the system evaporator temperature to set points #118, #121 and #124.

If the system evaporator temperature is greater than #124, DEF LOW TEMP but less than #121, DEF MED TEMP, then the approach set up will be based upon the medium temperature values.

Approach Temperature = set point #122

Defrost Duration = set point #123

If the system evaporator temperature is less than #124, DEF LOW TEMP, then the approach set up will be based upon the low temperature values.

Approach Temperature = set point #125

Defrost Duration = set point #126

After a defrost cycle, the pre defrost approach values will remain for the time specified in set point #131 then they will be reestablished according to the evaporator temp sensor input value.

If the evaporator temp sensor input value reads greater than setpoint #118, defrost will be disabled.

These values are displayed in both the MCS-Connect program and on the Magnum screen under status.

MCS-Connect program under the Status tab:

Capacity Control State	Time	Wanted/ Actual	Step Delay	Def. App.(Air) /Def. Time(Air)	Def. App.(Backup) /Def. Time(Backup)	Rate of Change	Control On	Wanted %
RUN/STOP SW OFF	00:03:13	0/0	120	20.0P / 00:07:00	30.0P / 00:04:00	0.0	VOLTAGE	N/A

Defrost setup for approach is displayed in column "Def. Approach/Def. Time".

Magnum under the Status option under the Main Menu, scroll to any of the circuit screens:

09: 55	CMP #(x)		+5. 0v
CMP OFF/READY			
000: 00: 42			
<u>SST</u>	<u>SSH</u>	<u>SCT</u>	<u>DSH</u>
38	16. 9	97	79. 2
APP/TME 20. 0/00: 03: 00			
PG↑		PG↓	

HH: MM	CIRCUIT		CTL VOLTAGE
CURRENT CONTROL STATE			
TIME IN CURRENT STATE			
<u>SAT. SUCT.</u>	<u>SUCT. SHEAT</u>	<u>SAT. COND.</u>	<u>DISC HEAT</u>
TEMP	TEMP	TEMP	TEMP
UNIT'S defrost approach (repeated for each circuit)			
PAGE UP		PAGE DN	

NOTE: The approach set point and time (duration) will be displayed for each circuit.

12.2.1 Approach type based circuit evaporator temperature

The actual circuit approach temperature is the calculated as follows:

If an Evaporator Suction Pressure has been specified, this value will be converted into temperature according to the refrigerants PT Chart. This value is subtracted from the systems return temperature sensors value. This will be the approach value for that evaporator

Select Temperature, Refrigeration and Oil Indicators for Circuits										
Circuit # (reset button)	Oil Seal Temp	Oil Float	Leaving Temp	Refrigerant Temp	Refrig Level	Manual Defrost Switch	Evap Suct Temp	Evap Suct PSI		
1	...	Not Used	Not Used	Not Used	Not Used	Not Used	Not Used	Not Used	EvapTmp 1	EvapPsi 1
2	...	Not Used	Not Used	Not Used	Not Used	Not Used	Not Used	Not Used	EvapTmp 2	EvapPsi 2
3	...	Not Used	Not Used	Not Used	Not Used	Not Used	Not Used	Not Used	EvapTmp 3	EvapPsi 3
4	...	Not Used	Not Used	Not Used	Not Used	Not Used	Not Used	Not Used	Not Used	Not Used
5	...	Not Used	Not Used	Not Used	Not Used	Not Used	Not Used	Not Used	Not Used	Not Used
6	...	Not Used	Not Used	Not Used	Not Used	Not Used	Not Used	Not Used	Not Used	Not Used
7	...	Not Used	Not Used	Not Used	Not Used	Not Used	Not Used	Not Used	Not Used	Not Used
8	...	Not Used	Not Used	Not Used	Not Used	Not Used	Not Used	Not Used	Not Used	Not Used
9	...	Not Used	Not Used	Not Used	Not Used	Not Used	Not Used	Not Used	Not Used	Not Used

If the evaporator suction pressure sensor has not been specified then the Circuit Suction Pressures value will be converted into temperature according to the refrigerants PT Chart. This value is subtracted from the systems return temperature sensors value. This will be the approach value for that evaporator.

State	Time	PSI Diff	Sat. Evap.	Evap App.(Air) (Time (Air))	Evap. App.(Backup) (Time (Backup))	Evap. Superheat	FLA %	Forced Defrost Delay(145)	Lead?	Manual FLA %
1)CMP OFF/READY	00:38:32	150.0P	16.2 / 0	13.8F / 00:03:00	13.8F / 00:02:00	18.8	100%	18:00:00	Yes	N/A
2)CMP OFF/READY	00:39:06	150.0P	16.2 / 0	13.8F / 00:03:00	13.8F / 00:02:00	18.8	98%	18:00:00		N/A

This value is displayed for each circuit in MCS-Connect under the Status Tab in the column “Evap. Approach/Time”. For circuit 1) the 12.4F is the calculated circuit evaporator temperature and time of 00:02:00 is the time that this temperature must be greater than the Defrost Approach temperature. This time is based upon the value of set point #137, DEF APPR TIME. When the compressor is running and the temperature is greater than the defrost approach temperature this counter will be decremented. If the temperature is less then it will be reset to the value in set point #137.

This value is display locally on the Magnum LCD under “Approach”.

09: 55	DEFROST #	(X) +5.0V
FroceDef (118) 01: 58: 23		
<u>EVAP</u>	<u>Approach</u>	<u>Del ay</u>
41. 1	50. 0	3: 00
<u>EVSat</u>	<u>EVSh</u>	<u>E Lead</u>
18. 1	87. 4	1
	PG↑	PG↓

HH:MM	DEFROST INFORMATION	CTL VOLTAGE
Time when next forced defrost is scheduled, will decrement		
Evap pressure	Approach pressure	Delay for approach
PSI	PSI	Counter decrementing
<u>Evap Sat.</u>	<u>Evap SHEAT</u>	Evap Lead
TEMP	TEMP	#
	PAGE UP	PAGE DN

12.3. Defrost Ready Indicator

MAG REFR software will turn on a relay output when the system is getting ready to enter a defrost cycle. This must be setup in the cell “Defrost Slave” Indicator in the Evaporator Information section under the MAG REFR button. If not in defrost this relay output will be off.

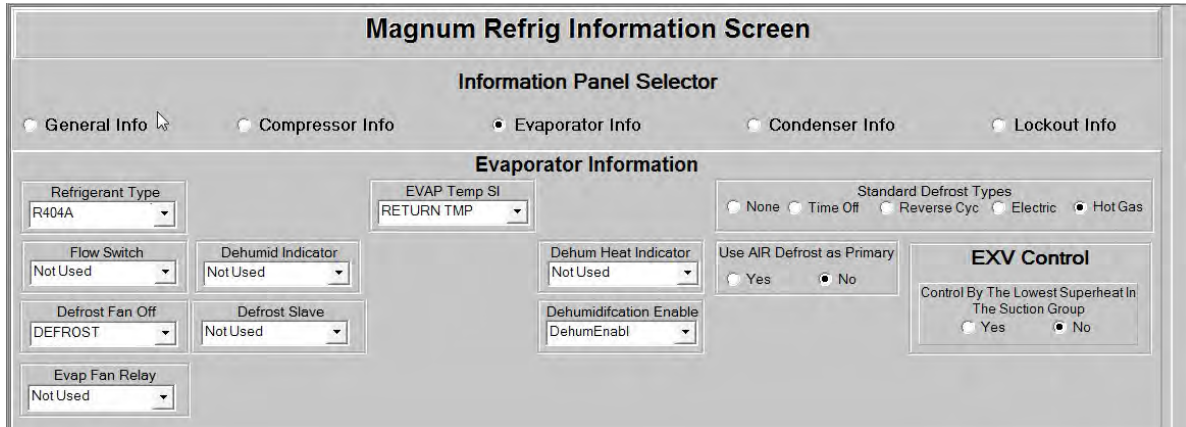

12.4. Defrost Indicator

MAG REFR software will turn on a relay output when the system is in a defrost cycle. This must be setup in the cell “Defrost Fan Off” in the Evaporator Information section under the MAG REFR button. If not in defrost this relay output will be off.

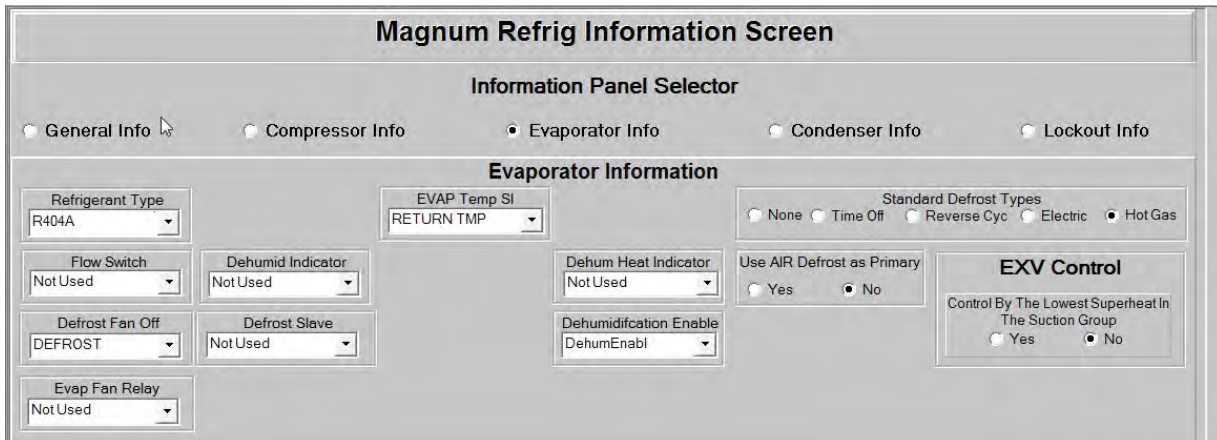

12.5. Defrost Indicator setup

These indicators must be setup in the Evaporator Information Section under the MAG REFR in the MCS-Config program.

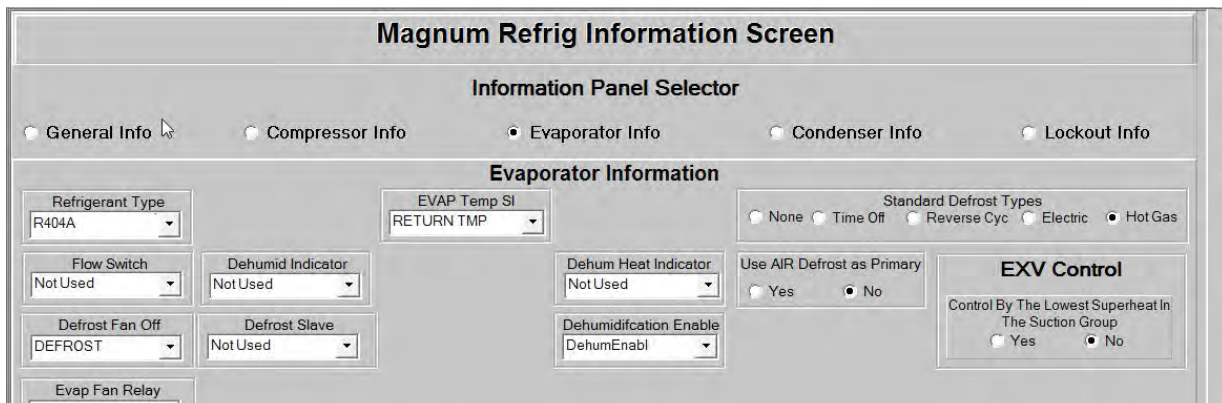

12.6. Defrost Types supported:

REFR firmware supports several different types of defrost:

- None
- Time Off
- Reverse Cycle
- Electric
- Hot Gas Standard (all coils defrost at once)
- Hot Gas On The Fly (One Coil is defrosted at a time)
- Air Defrost
- Rotating Coil, with Reheat

Defrost Types are selected in the Evaporator Information Section under the MAG REFR in the MCS-Config program. If AIR Defrost Type is YES, then the Standard Defrost Type selected will be used as backup. Defrost - None

No defrost is performed. The defrost approach will indicate NO DEF. One liquid line solenoid is required no other defrost relay output points are required.

12.7. Defrost - Time Off

The Time OFF defrost type functions exactly like electric defrost except there is no electric defrost relay to be turned on.

12.8. Defrost - Reverse Cycle

The Reverse Cycle defrost type is specified for a heat pump type of compressor.

The following table shows the RO status and the circuit states during defrost cycles.

	Normal	DEF-START CMP	PUMP DOWN	DEFROST COILS	PUMP DOWN	DRIP DOWN
Comp	ON	ON	ON	ON (StPt #166)	ON	OFF
LLS #1	ON	ON	OFF	OFF	OFF	OFF
LLS #2	ON	ON	OFF	OFF	OFF	OFF
REV VALVE	OFF	OFF	OFF	ON	OFF	OFF

The DEF-PUMP DOWN state can be terminated for the following reasons:

- Time in state exceeds the value of set point #141.
- Suction pressure decreases by more than the value of set point #142

The DEFROST COILS state can be terminated for the following reasons:

- Time in state exceeds the time indicated by set point #120 if high temperature, set point #123 if medium temperature, set point #126 if low temperature, or set point #128 if in dehumidify mode.
- Evaporator temperature is equal to or greater than value of set point #143.
- Discharge pressure is equal to or less than value of set point #144.

12.9. Defrost - Electric

This type of defrost requires the circuit to consist of one or more evaporators with one liquid line and electric heat relay per circuit. When a defrost cycle is required, the system will turn off the compressor. The circuit states will indicate which evaporator is in a defrost mode. The electric heat relay will be turned on when the state is in DEFROST COILS.

Following table shows the status of the circuit RO's when in various defrost states.

	Normal	PUMP DOWN	DEFROST COILS
Comp	ON	ON	OFF
LLS #1	ON	OFF	OFF
LLS #2	ON	OFF	OFF
ELEC DEFROST	OFF	OFF	ON

The DEFROST COILS state can be terminated for the following reasons:

- Time in state exceeds the time indicated by set point #120 if high temperature, set point #123 if medium temperature, set point #126 if low temperature, or set point #128 if in dehumidify mode.
- Evaporator temperature is equal to or greater than value of set point #143.

12.10. Defrost - Hot Gas - Conventional (set point #117 = Active)

This type of defrost requires the circuit to consist of two separate evaporators with a liquid line and a hot gas solenoid for each. A defrost cycle will defrost both evaporators at the same time. When a compressor requires a defrost cycle, that compressor will defrost and all other compressors will be checked if their accumulated run time is greater than the value in set point #130 they will also enter a defrost cycle. If not, the compressor will be turned off until all defrost cycles have been completed. The circuit states will indicate which evaporator is in a defrost mode.

Following table shows the status of the circuit RO's when in various defrost states. The compressor states are not shown. When a defrost cycle begins, the circuit states will move from left to right as indicated below until both evaporators have been defrosted and then the circuit will return to a normal state.

	Normal	DEF-START CMP	PUMP DOWN	DEFROST COILS	PUMP DOWN	DRIP DOWN
Comp	ON	ON	ON	ON	ON	OFF
LLS #1	ON	ON	OFF	OFF	OFF	OFF
LLS #2	ON	ON	OFF	OFF	OFF	OFF
Hot Gas Main	OFF	OFF	OFF	ON (StPt #135)	OFF	OFF
Hot Gas Def 1	OFF	OFF	OFF	ON	OFF	OFF
Hot Gas Def 2	OFF	OFF	OFF	ON	OFF	OFF
Hot Gas Bleed	OFF	OFF	OFF	ON	OFF	OFF

The DEF-PUMP DOWN state can be terminated for the following reasons:

- Time in state exceeds the value of set point #141.
- Suction pressure is equal to or less than value of set point #142.

The DEFROST COILS state can be terminated for the following reasons:

- Time in state exceeds the time indicated by set point #120 if high temperature, or set point #123 if medium temperature, or set point #126 if low temperature or set point #128 if in dehumidify mode.
- Evaporator temperature is equal to or greater than value of set point #143.
- Discharge pressure is equal to or less than value of set point #144.

12.11. Defrost - Hot Gas on the Fly (set point #117 = Inactive)

This type of defrost requires the circuit to consist of two separate evaporators with a liquid line and a hot gas solenoid for each. When a defrost cycle is required, the circuit will defrost one evaporator at a time. The circuit states will indicate which evaporator is in a defrost mode.

Following table shows the status of the circuit RO's when in various defrost states. The compressor states are not shown. When a defrost cycle begins, the circuit states will move from left to right as indicated below until both evaporators have been defrosted and then the circuit will return to a normal state.

	Normal	DEF EVAP #1	DRIP DOWN #1	DEF EVAP #2	DRIP DOWN #2	NORMAL
Comp	ON	ON	ON	ON	ON	ON
LLS #1	ON	OFF	OFF	ON	ON	ON
LLS #2	ON	ON	ON	OFF	OFF	ON
HOT GAS MAIN	OFF	ON (StPt #135)	OFF	ON (StPt#135)	OFF	OFF
HOT GAS DEF 1	OFF	ON	OFF	OFF	OFF	OFF
HOT GAS DEF 2	OFF	OFF	OFF	ON	OFF	OFF
HOT GAS BLEED	OFF	ON	OFF	ON	OFF	OFF

The DEFROST COILS state can be terminated for the following reasons:

- Time in state exceeds the time indicated by set point #120 if high temperature, set point #123 if medium temperature, or set point #126 if low temperature.
- Evaporator temperature is equal to or greater than value of set point #143.
- Discharge pressure is equal to or less than value of set point #144.

12.12. Rotating Compressor Air Defrost Selection:

The Rotating Compressor Air Defrost option selection is made in the Evaporator Information section under the MAG REFR button. Selecting YES in the cell labeled "Only Use AIR Defrost Type" activates this option. Other types of defrost are available as a backup, if specified in this cell. The option to look at a digital input exists that, when on, will disable Air Defrost and only use the backup defrost type. This option will use evaporator approach to initiate defrost, and rotate through running/non running compressors using times and approach values defined in setpoints #236 through #246.

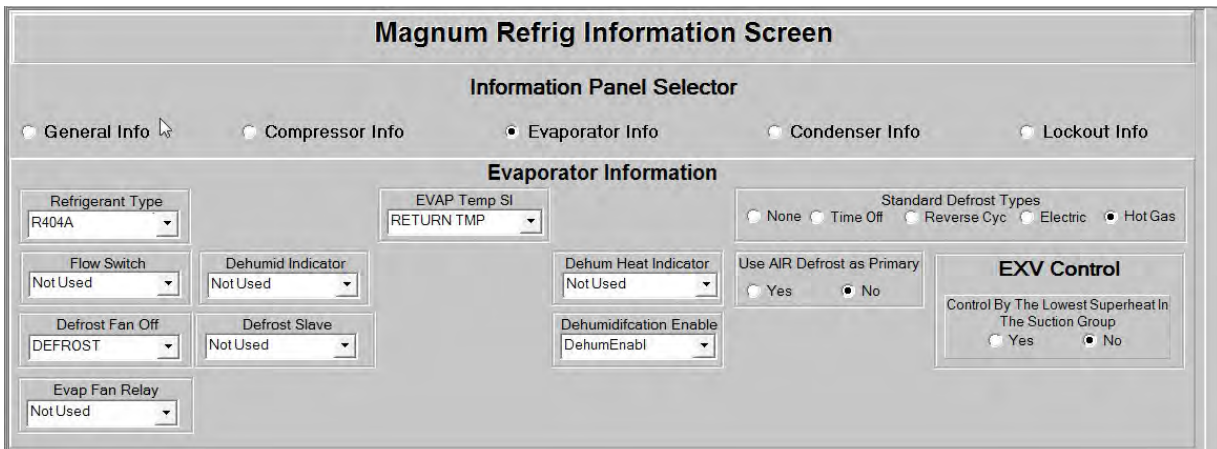

12.12.1 Defrost function:

The system will support a normal defrost cycle based upon approach, and use specified backup defrost if needed. The goal is to defrost the evaporators based solely on time off. This is accomplished by rotating the compressors. A system with 4 compressors will turn on the number of compressors required by the staging logic. If the logic calls for 3 of the 4 compressors to run, the defrost logic will monitor the approach of each running circuit. Once a circuits approach meets the calculated air defrost approach value, for greater than the air defrost trigger time, the circuit will enter the "Def – Air Normal" state. During this time, a Non-Running compressor will be brought on. The compressor requiring defrost will continue to be ran, along with the recently started compressor, for the value in setpoint #245. The purpose of this is to allow the recently started compressor time to get to capacity. Once this time elapses, the compressor calling for defrost is cycled OFF for the amount of time in the calculated Air Defrost setpoint.

Once this time expires, the compressor will enter the “Off /Ready” state. At this instant, the next compressor in the sequence will be placed into the “Def – Air Normal” state. The compressor that just finished it’s defrost cycle, will be started and will run together for the time in setpoint #245. Once this time expires, the compressor slated for defrost will be cycled OFF.

This procedure will continue for ALL compressors on the unit.

If a Backup Defrost option was selected, the logic will continue to monitor evap approach for running compressors, if any approach values rise above the calculated backup defrost setpoints (Setpoints #118 through #126), then a backup defrost will be initiated.

12.12.2 Defrost is initiated

Defrost cycles are initiated based on evaporator approach.

Air defrost uses setpoint #236 through #246 to determine the condition, approach value, and time in defrost for the unit. If a backup defrost is set for an air defrost unit, the logic uses the standard defrost setpoints for the defrost values. It is important, that the trigger delay for the backup defrost (Setpoint #137) always be a lesser value than the trigger delay for the Air Defrost (Setpoint #246).

Backup defrost, if selected, uses setpoints #118 through #126 to determine the condition, approach value, and time in defrost for the unit.

If a digital input is selected, when this input is “ON” Air Defrost will be disabled. The logic will only compare the evaporator approach to setpoints #118 through #126 and use the backup defrost method selected.

12.13. Defrost - Multiple Evaporator/Reheat

12.13.1 Purpose of Multiple Evaporator/Reheat:

Provides an option to build units with multiple evaporators and reheat solenoids in place of liquid line solenoids. The evaporators provide cooling control while the reheat solenoids will provide defrost capabilities.

12.13.2 Multiple Evaporator/ Reheat (normal) Selection:

12.13.3 Compressor Info window:

- **Compressor Type; Hanbell Screw (any variable capacity compressor).**

12.13.4 Evaporator Info window:

- **Standard Defrost Types; Electric.**
- **Use AIR Defrost as Primary; No.**

12.13.5 Circuit Base:

- **Type of LLS; LLS only.**
- **2nd LLS; No.**
- **Number of EVAP/REHT; number of evaporators (maximum of 6).**
- **Max EVAP/REHT ON; not used at this time.**
- **Are There Reheat Relays; YES indicates that there are reheat relays.**
- **Allow Reheat Relays; index of sensor input that indicates whether reheat is required, ON allows reheat relays to be turned on if specified.**
- **Reheat Voltage SI; index of sensor input that provides a voltage indicating number of reheat required. Refer to set points #248 through #253.**

12.13.6 Relay output sequence for a variable compressor with 4 EVAP/REHT:

- COMP (no split winding)
- LOAD ER
- UNLOADER
- EVAP 1
- EVAP 2
- EVAP 3
- EVAP 4
- REHEAT 1
- REHEAT 2
- REHEAT 3
- REHEAT 4

12.13.7 Relationship of evaporators and reheat:

- If reheat relays are selected, the number of reheat relays is the same as the number of evaporators.
- Reheat relays are tied to the corresponding evaporator (reheat 1 is tied to evaporator 1, etc.).
- If the corresponding evaporator is ON then the reheat is OFF
- If the compressor is running and not in dehumidification mode and the return (EVAP temp) temperature is above the HIGH DEFROST TEMPERATURE then all evaporator relays will be ON and all reheat relays will be OFF.
If the compressor is running and not in dehumidification mode and the return (EVAP temp) temperature is less than or equal to the HIGH DEFROST TEMPERATURE then one less than the number of evaporator relays will be ON. The evaporator relays can be rotated based upon set point #134, this will enable a reheat relay to be turned ON.
If system is in dehumidification mode and the compressor is running; then only one half of the evaporator relays will be turned ON The evaporator relays can be rotated based upon set point #134, this will enable reheat relays to be turned ON. This will force rotation of the reheat relays if any are ON.
- If the unit's state is running (not forced off) and the compressor is OFF then all evaporator relays will be off and the reheat relays can be turned ON if needed. Reheat relays can be turned ON with the compressor OFF.
If the unit state is forced off, RUN/STOP off, EMGENCY STOP is on etc., then all compressor, evaporators and reheat relays will be off.

12.13.8 Set points that support this selection:

- #134, EVAP rotation; if this set point is active and its value is greater than zero then the evaporators will be rotated when the number of evaporator relays that are ON is less than the number available. The value which is expressed in minutes is the time between rotations.
- #247, Reheat offset OFF, subtracted from the reheat stage on value, to determine when a heater will be turned off.
- #248 -253, REHT STAGE #; voltage value: will enable reheat from 1 through 6 (these function like the STAGE # ON set points).

12.13.9 Defrost; Electric type with multiple evaporator/reheat relays:

Standard defrost set points must be setup. The unit will develop the unit approach and when the circuit meets the approach requirement a defrost cycle will be initialized. Defrost set up and states are similar to the Electric defrost type. All compressors will enter the defrost cycle.

Defrost states when a circuit is running:

- Unit state & circuit state will be DEF START COMP; in this state the compressor and all evaporators will be ON. All other relays will be OFF. Circuit will remain in this state for Time (SEC) value of set point #138. To eliminate this state set Time (SEC) value to zero.
- Unit state will be DEFROST COILS and the circuit state will be DEF PUMP DOWN. In this state the compressor will be on and all other relays will be off. Circuit will remain in this state until either the discharge pressure has reached the pump down value or the time has exceeded the time value.
- Unit state will be DEFROST COILS and the circuit state will be DEFROST COILS. In this state all reheat relays will be on and all other relays will be off, the reheat solenoids are providing the heat for the defrost cycle and the sensor input allowing reheat and the number are ignore. Circuit will remain in this state until the defrost time has been reached or the evaporator temperature is equal to or greater than the value of set point # 143.
- Unit state will be DEFROST COILS and the circuit state will be DRIP DOWN. In this state all circuit relays will be off. The circuit will remain in this state for time in the value cell of set point #132.
- System will return to normal operation.

Defrost states when a circuit is NOT running:

- The compressor is off; therefore, the DEF PUMP DOWN state will be skipped.
- Unit state will be DEFROST COILS and the circuit state will be DEFROST COILS. In this state all reheat relays will be on and all other relays will be off, the reheat solenoids are providing the heat for the defrost cycle and the sensor input allowing reheat and the number are ignore. Circuit will remain in this state until the defrost time has been reached or the evaporator temperature is equal to or greater than the value of set point # 143
- Unit state will be DEFROST COILS and the circuit state will be DRIP DOWN. In this state all circuit relays will be off. The circuit will remain in this state for time in the value cell of set point #132.
- System will return to normal operation.

12.14. Unit Operating with the Evaporator/Reheat Selection

Unit set up:

- Two variable drive compressors
- Four evaporator and reheat relays per circuit

12.14.1 **Unit is in normal mode (not dehumidification) & circuit is on**

- Compressors staging is based upon staging voltage input.
- If the return (EVAP temp) temperature is above the HIGH DEFROST TEMPERATURE then all evaporator relays will be ON and all reheat relays will be OFF.
- If the return (EVAP temp) temperature is less than or equal to the HIGH DEFROST TEMPERATURE then one less than the number of evaporator relays will be ON. The evaporator relays can be rotated based upon set point #134, this will enable a reheat relay to be turned ON.

12.14.2 **1.3.2 Unit is in dehumidification mode & circuit is on**

- All compressors are staged together; the voltage input will be varied between the first cut in, set point #206 minus setpoint #205, and the set point with maximum voltage. In our example with 2 circuits that would be set point #208. To avoid peak power issues the second, next, compressor will be turned on once the delay has been counted down. The compressor will remain on until the voltage is less than value of setpoint #206 – Setpoint #205.
- If compressor is on then only one half of the evaporator relays are on others will be off.
- **If set point #134 is active and its value is greater than zero; then the evaporator relays will be rotated based upon the value of this set point. Value is expressed in minutes.**
If the sensor allowing reheat is on and the voltage sensor indicating the number of reheat relays that can be turned will allow up to one half reheat relays to be turned on. If the evaporator relays are rotated, the reheat relays will also be rotated.

12.14.3 Unit is a normal mode & circuit is off

If the sensor allowing reheat is on and the voltage sensor indicating the number of reheat relays that can be turned will allow the reheat relays to be turned on. No rotation of reheat relays will occur.

12.14.4 Unit is a NOT in a normal mode (RUN/STOP, Emergency Stop etc.)

All circuit relays will be off.

Chapter - 13. Dehumidify Function

This function is setup by selecting a sensor input in the cell Dehumidification Enable in the Evaporator Information section under the MAG REFR button.

The screenshot displays the 'Magnum Refrig Information Screen' with the 'Evaporator Info' tab selected. The 'Evaporator Information' section contains the following controls:

- Refrigerant Type:** R404A
- EVAP Temp SI:** RETURN TMP
- Standard Defrost Types:** None, Time Off, Reverse Cyc (selected), Electric, Hot Gas
- Flow Switch:** Not Used
- Dehumid Indicator:** Not Used
- Dehum Heat Indicator:** Not Used
- Evap Fan Relay:** Not Used
- EXV Control:** Control By The Lowest Superheat In The Suction Group (Yes, No) - No is selected.
- Defrost Fan Off:** DEFROST
- Defrost Slave:** Not Used
- Dehumidification Enable:** Not Used
- Only Use AIR Defrost Type:** YES, NO (NO is selected)

MAG REFR software will turn on a relay output when the system is in the dehumidification mode. This must be setup in the cell "Dehumidify Indicator" in the Evaporator Information section under the MAG REFR button. If not in dehumidification mode this relay output will be off.

When the Dehumidification Enable sensor is on, the approach temperature and time will be changed to the values in set point #127, DEF DEH APPR for temperature, and set point #128, DEF DEH TIME for time. When is indicator is on, the system will provide only half of its cooling capacity.

When in dehumidification, if the approach value satisfies the approach setpoints, the logic will turn off LLS #1 and Turn on LLS #2. There, the logic will monitor the approach for the 2nd LLS. Once the 2nd LLS's approach value meets the defrost setpoint requirements, a defrost cycle will be initiated.

Chapter - 14. Common Definitions

14.1. How a Defrost Cycle can be initiated

A defrost cycle can be initiated by the approach set point temperature and time being satisfied, by the time in setpoint #145 expiring, or by the Manual Defrost Switch being on. Manual Defrost Switch if it exists must be setup in the Circuits grid under the MAG REFR button.

14.1.1 Approach Set point Temperature & Time (Air Defrost)

The evaporator temperature sensor input (must be setup as the Entering Temperature in the Evaporator Information section under the MAG REFR button in the MCS-Config program) determines which approach values will be used. The approach values will be recalculated after a defrost cycle, once the time in set point #131 has been met.

If this temperature is greater than set point #236, Air Defrost High Temp, then no air defrost is required. Approach will indicate NO DEF.

If the temperature is less than set point #236 (Air Defrost High Temp) but greater than set point #239 (Air Defrost Medium Temp), the approach set point temperature will be set point #237 (Air Defrost High Approach) and the time will be set point #238 (Air Defrost High Time).

If the temperature is less than set point #239 (Air Defrost Medium Temp) but greater than set point #122 (Air Defrost Low Temp), the approach set point temperature will be set point #240 (Air Defrost Medium Approach) and the time will be set point #241 (Air Defrost Medium Time).

If the temperature is less than set point #242 (Air Defrost Low Temp) the approach set point temperature will be set point #243 (Air Defrost Low Approach) and the time will be set point #244(Air Defrost Low Time).

If the temperature is less than setpoint #242 minus the value in its Low Zone, the conditions are too cold to use Air Defrost, and it will be disabled. Backup Defrost, if present, will only be allowed.

14.1.2 Approach Set point Temperature & Time (Standard Defrost)

The evaporator temperature sensor input (must be setup as the Entering Temperature in the Evaporator Information section under the MAG REFR button in the MCS-Config program) determines which approach values will be used.

The approach values will be recalculated after a defrost cycle, once the time in set point #131 has been met.

If this temperature is greater than set point #118, DEF HI TEMP, then no defrost is required. Approach will indicate NO DEF.

If the temperature is less than set point #118 but greater than set point #121, DEF MED TEMP; the approach set point temperature will be set point #119, DEF HI APPR and the time will be set point #120, DEF HI TIME.

If the temperature is less than set point #121 greater than set point #122, DEF LOW TEMP; the approach setpoint temperature will be set point #122, DEF MED APPR and the time will be set point #123, DEF MED TIME.

If the temperature is less than set point #124, DEF LOW TEMP; the approach set point temperature will be set point #125, DEF LOW APPR and the time will be set point #126, DEF LOW TIME.

14.1.3 Approach Actual Temperature & Time

The actual circuit approach temperature is the calculated as follows:

If an evaporator suction pressure sensor has been specified in the Circuit SI grid

Select Temperature, Refrigeration and Oil Indicators for Circuits									
Circuit # (reset button)	Oil Seal Temp	Oil Float	Leaving Temp	Refrigerant Temp	Refrig Level	Manual Defrost Switch	Evap Suct Temp	Evap Suct PSI	
1	Not Used	Not Used	Not Used	Not Used	Not Used	Not Used	EvapTmp 1	EvapPsi 1	
2	Not Used	Not Used	Not Used	Not Used	Not Used	Not Used	EvapTmp 2	EvapPsi 2	
3	Not Used	Not Used	Not Used	Not Used	Not Used	Not Used	EvapTmp 3	EvapPsi 3	
4	Not Used	Not Used	Not Used	Not Used	Not Used	Not Used	Not Used	Not Used	Not Used
5	Not Used	Not Used	Not Used	Not Used	Not Used	Not Used	Not Used	Not Used	Not Used
6	Not Used	Not Used	Not Used	Not Used	Not Used	Not Used	Not Used	Not Used	Not Used
7	Not Used	Not Used	Not Used	Not Used	Not Used	Not Used	Not Used	Not Used	Not Used
8	Not Used	Not Used	Not Used	Not Used	Not Used	Not Used	Not Used	Not Used	Not Used
9	Not Used	Not Used	Not Used	Not Used	Not Used	Not Used	Not Used	Not Used	Not Used

The evaporator suction temperature will be the evaporator suction pressure converted to temperature. If the evaporator suction pressure sensor has not been specified then the evaporator suction temperature will be the circuit suction pressure plus the value of set point #203, SAT EVAP DIFF which is then converted to temperature.. This value is displayed for each circuit in MCS-Connect under the Status Tab in the column “Evap. Approach/Time”.

14.1.4 Defrost Fan Relay

MAG REFR software will turn on a relay output when the system is getting ready to enter a defrost cycle. This must be setup in the cell Defrost Ready Indicator in the Evaporator Information section under the MAG REFR button. If not in defrost this relay output will be off.

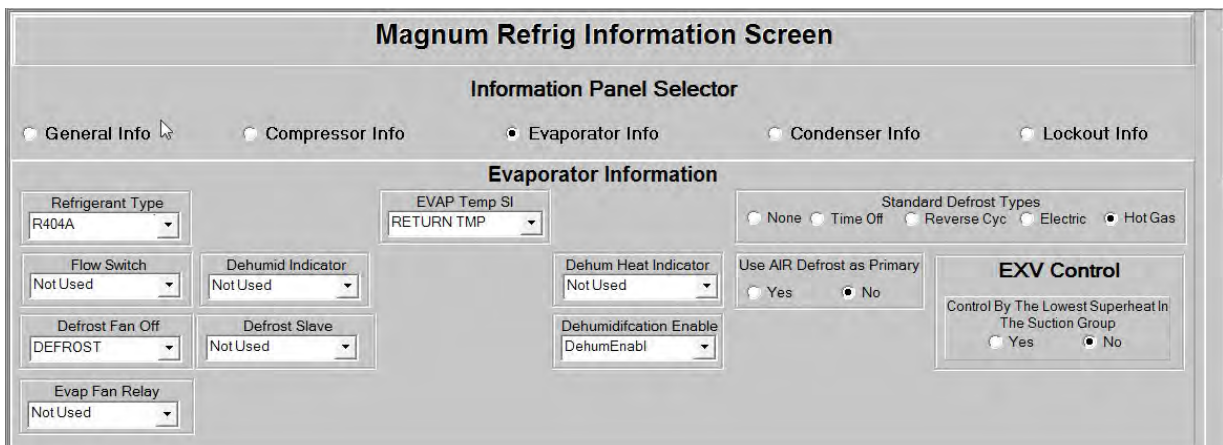

14.1.5 Defrost Slave

MAG REFR software will turn on a relay output when the system is in a defrost cycle. This must be setup in the cell Defrost Indicator in the Evaporator Information section under the MAG REFR button. If not in defrost this relay output will be off.

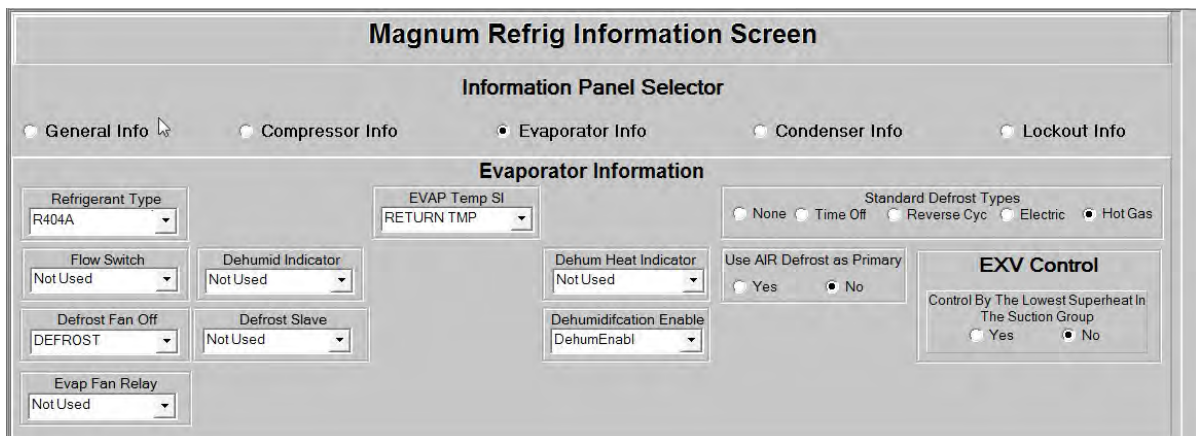

Chapter - 15. Magnum Displays

15.1. Menu Key

Pressing the 'Menu' key provides the following: The display shows options available.

<u>ACTUAL DISPLAY</u>	<u>DESCRIPTION</u>
<pre> 09: 56 Main Menu - Status - Setpoints - Outputs - Serv Tools - Inputs - Lckout RST - Alarms - Lckout ALM - Graphs - Passwords Help </pre>	<pre> HH: MM Screen Title - Control Status Display - Active set pts Display - Relay/Anal og Di spl ay - Service Tools Di spl ay - Sensor Input Di spl ay - Lockout Reset Di spl ay - Al arm Di spl ay - Lockout Al arm Di spl ay - Graphi ng Di spl ay - Password Di spl ay Help </pre>

15.2. Status Display – Chiller (Default at Power Up)

The CURRENT STATE OF THE PACKAGE.

The display shows the current capacity of the package and how long we have been at this level. By pressing the **PG↑** OR **PG↓** you will get additional information on each circuit.

<u>ACTUAL DISPLAY</u>	<u>DESCRIPTION</u>
<pre> 09: 55 Uni t +5. 0v UNIT IS UNLOADED 025: 42: 33 WID ACT FLA% DLY ROC 0 0 40% 180 0. 0 CTL ON VOLTAGE +5. 0V PG↑ PG↓ </pre>	<pre> HH: MM CHILLER UNIT CTL VOLTAGE CURRENT CONTROL STATE TIME IN CURRENT STATE WANTED ACTUAL WANTED% DELAY SLOPE #STEPS #STEPS ACTUAL% NEXT CHG DIRECTION INDICATES CONTROL ON VOLTAGE OR TEMP PAGE UP PAGE DN </pre>

15.3. Status Display – Circuit (x)

The CURRENT STATE OF A CIRCUIT.

The display shows the current capacity of circuit (x) and how long we have been at this level. By pressing the **PG↑** you will go back to the Chiller state display OR **PG↓** you will get additional information on this circuit.

<u>ACTUAL DISPLAY</u>	<u>DESCRIPTION</u>
<pre> 09: 56 CMP #(x) +5. 0v CMP OFF/READY 000: 00: 30 SUCT DISC OPD MOTOR 66P 190P 134P 0% 55F 177F ---- OK PG↑ PG↓ </pre>	<pre> HH: MM CIRCUIT CTL VOLTAGE CURRENT CONTROL STATE TIME IN CURRENT STATE SUCTION DISCHARGE OIL DIFFERENTIAL MOTOR PRESSURE PRESSURE PRESSURE AMP % TEMPERATURE TEMPERATURE ----- STATUS PAGE UP PAGE DN </pre>
<pre> 09: 55 CMP #(x) +5. 0v CMP OFF/READY 000: 00: 42 SST SSH SCT DSH 38 16. 9 97 79. 2 PG↑ PG↓ </pre>	<pre> HH: MM CIRCUIT CTL VOLTAGE CURRENT CONTROL STATE TIME IN CURRENT STATE SAT. SUCT. SUCT SHEAT SAT. COND. DISC HEAT TEMP TEMP TEMP TEMP PAGE UP PAGE DN </pre>

By pressing the PG↑ you will go back to the previous display OR PG↓ you will get information on the next circuit. After all circuit information is displayed pressing the PG↓ will return the user to the chiller display.

09: 55	DEFROST #	(X) +5. 0V
Nxt Air Defr	01: 58: 23	
<u>EVAP</u>	<u>Trigger</u>	<u>Delay</u>
41. 1	50. 0	3: 00
<u>EVSat</u>	<u>EVShT</u>	<u>E Lead</u>
18. 1	87. 4	1
	PG↑	PG↓

HH:MM	DEFROST INFORMATION	CTL VOLTAGE
Time when next air defrost is scheduled, will decrement		
Evap pressure	Trigger pressure	Delay for trigger
PSI	PSI	Counter decrementing
<u>Evap Sat.</u>	<u>Evap SHEAT</u>	Evap Lead
TEMP	TEMP	#
	PAGE UP	PAGE DN

15.4. Outputs

Selecting the 'Outputs' option provides the following:

ACTUAL DISPLAY

DESCRIPTION

09: 56	Outputs	◀ ▶
Relays	Status	
M- 1 COMP1A	Lck Off	
M- 2 COMP1B	Lck Off	
M- 3 LOAD1	Lck Off	
M- 4 UNLOAD	Lck Off	
<u>Anl og</u>	PG↑	PG↓

HH: MM	Screen Title	Left/Right Arrow
RO position & names	Current status of RO	
Using Left/Right arrow allows user to view all data for RO's displayed		
Switch to AO's	Page up	Page down

Selecting the Page Down option provides the following:

ACTUAL DISPLAY

DESCRIPTION

09: 56	Outputs	◀ ▶
Relays	Status	
M- 5 FAN1	On	
M- 6 FAN2	On	
M- 7 FAN3	On	
M- 8 FAN4	On	
<u>Anl og</u>	PG↑	PG↓

HH: MM	Screen Title	Left/Right Arrow
RO position & names	Current status of RO	
Using Left/Right arrow allows user to view all data for RO's displayed		
Switch to AO's	Page up	Page down

Selecting the Page Down option provides the following:

ACTUAL DISPLAY

DESCRIPTION

09: 56	Outputs	◀ ▶
Relays	Status	
M- 9 FAN5	On	
M- 10 ALARM	Off	
<u>Anl og</u>	PG↑	PG↓

HH: MM	Screen Title	Left/Right Arrow
RO position & names	Current status of RO	
Using Left/Right arrow allows user to view all data for RO's displayed		
Switch to AO's	Page up	Page down

15.5. Inputs

Selecting the 'Inputs' option provides the following:

ACTUAL DISPLAY

09: 56	Inputs	◀ ▶
Sensor	Value	
M-1 SUCT1	66. 0P	
M-2 DISC1	121. 3P	
M-3 AMPS1	0. 0A	
M-4 SUCTTMP1	52. 3F	
	PG↑	PG↓

DESCRIPTION

HH: MM	Screen Title	Left/Right Arrow
SI position & names	Current status of SI	
Using Left/Right arrow allows user to view all data for SI's displayed		
	Page up	Page down

Selecting the Page Down option provides the following:

ACTUAL DISPLAY

09: 56	Inputs	◀ ▶
Sensor	Value	
M-1 SUCT1	44. 0P	Man
M-2 DISC1	222. 0P	Man
M-3 AMPS1	98. 0A	Man
M-4 SUCTTMP1	33. 0F	Man
Anlog	PG↑	PG↓

DESCRIPTION

HH: MM	Screen Title	Left/Right Arrow
SI position & names	Current status of SI	
Using Left/Right arrow allows user to view all data for SI's displayed		
Switch to A0's	Page up	Page down

Selecting the Page Down option provides the following:

ACTUAL DISPLAY

09: 56	Inputs	◀ ▶
Sensor	Value	
M-5 DISCTMP1	177. 0F	Man
M-6 MOTFLT1	NO	Man
M-7 PUMPDOWN1	NO	Man
M-8 COMPOIL1	200. 0P	Man
Anlog	PG↑	PG↓

DESCRIPTION

HH: MM	Screen Title	Left/Right Arrow
SI position & names	Current status of SI	
Using Left/Right arrow allows user to view all data for SI's displayed		
Switch to A0's	Page up	Page down

Selecting the Page Down option provides the following:

ACTUAL DISPLAY

09: 56	Inputs	◀ ▶
Sensor	Value	
M-9 ENT LIQ	35. 0F	Man
M-10LEV LIQ	25. 0F	Man
M-11AMBIENT	88. 0F	Man
M-12FLOW	ON	Man
Anlog	PG↑	PG↓

DESCRIPTION

HH: MM	Screen Title	Left/Right Arrow
SI position & names	Current status of SI	
Using Left/Right arrow allows user to view all data for SI's displayed		
Switch to A0's	Page up	Page down

Selecting the Page Down option provides the following:

ACTUAL DISPLAY

09: 56	Inputs	◀ ▶
Sensor	Val ue	
M-13RUN/STOP	RUN Man	
M-14PHASLOSS	NO Man	
Anl og	PG↑	PG↓

DESCRIPTION

HH: MM	Screen Title	Left/Right Arrow
SI position & names	Current status of SI	
Using Left/Right arrow allows user to view all data for SI's displayed		
Switch to A0's	Page up	Page down

15.6. Alarms

Selecting the 'Alarms' option provides the following:

ACTUAL DISPLAY

09: 56	Al arms	
1	LOST RO COMM	#2
	JUL 04	12:09:16
2	LOST RO COMM	#1
	JUL 04	12:09:16
	PG↑	PG↓

DESCRIPTION

HH: MM	Screen Title	
1 st Alarm #	Alarm Title	Unit Number
	Alarm Date & Time of 1 st alarm	
2 nd Alarm #	Alarm Title	Unit Number
	Alarm Date & Time of 2 nd alarm	
	Page up	Page down

15.7. Graphs

Selecting the 'Alarms' option provides the following:

ACTUAL DISPLAY

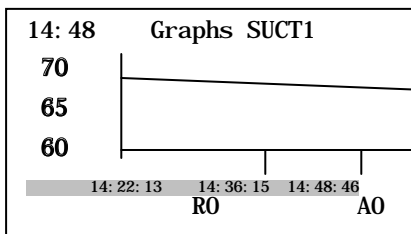

DESCRIPTION

HH: MM	Screen Title	Sensor Name
The graph has the last 25 samples with an appropriate scale to allow it to fit on the display. Using the up/down arrows will plot sensors before or after.		
	Switched to RO's	Switches to A0's

15.8. Set points

Selecting the 'Set points' option provides the following:

ACTUAL DISPLAY

09: 56	Setpoi nts	◀ ▶
Name	Val ue	
1	LEV TARGET	27. 0P
2	CTRL ZONE+	0. 5P
3	CTRL ZONE-	0. 0P
9	SUPERHT TARG	12. 5F
	PG↑	PG↓

DESCRIPTION

HH: MM	Screen Title	Left/Right Arrow
The Level Target is the targeted value. The Control Zone + creates the top of the control zone. The Control Zone - creates the bottom of the control zone. The Superheat Target is the target value the system will maintain. Use left/right arrows to see time and type.		
	Page up	Page down

Selecting the Page Down option provides the following:

<u>ACTUAL DISPLAY</u>	<u>DESCRIPTION</u>
<p>09: 56 Setpoints ◀ ▶</p> <p>Name Value</p> <p>10 SPRHT ZONE+- 2. 5F</p> <p>11 EXV LOAD ADJ 0. 5%</p> <p>12 EXV FINE ADJ 0. 1%</p> <p>13 EXV COURSE 0. 5%</p> <p style="text-align: right;">PG↑ PG↓</p>	<p>HH: MM Screen Title Left/Right Arrow</p> <p>This set point defines the width of each control zone. EXV load adjustments are made in response to a load or unload slide adjustment. EXV fine adjustments are made when in the 1st zone above or below the control zone. The EXV course adjustment is made when in the 2nd zone above or below the control zone. Use left/right arrows to see time and type.</p> <p style="text-align: center;">Page up Page down</p>

Selecting the Page Down option provides the following:

<u>ACTUAL DISPLAY</u>	<u>DESCRIPTION</u>
<p>09: 56 Setpoints ◀ ▶</p> <p>Name Value</p> <p>14 EXV LOAD DIV 3</p> <p>15 EXV MIN % 10. 0%</p> <p>16 EXV MAX % 50. 0%</p> <p>17 LO SUPERHEAT 2. 0F</p> <p style="text-align: right;">PG↑ PG↓</p>	<p>HH: MM Screen Title Left/Right Arrow</p> <p>EXV Load Division: Max slide% – min slide% / Max vlv% - min vlv%) +1. Minimum valve position allowed when modulating the expansion valve. Maximum position allowed when modulating the expansion valve. Low Superheat value before alarm is generated. Use left/right arrows to see time and type.</p> <p style="text-align: center;">Page up Page down</p>

Selecting the Page Down option provides the following:

<u>ACTUAL DISPLAY</u>	<u>DESCRIPTION</u>
<p>09: 56 Setpoints ◀ ▶</p> <p>Name Value</p> <p>18 LOSUCTPSIDL 30s</p> <p>19 EXV DELAY 60s</p> <p>20 EXV STRT TME 5s</p> <p>23 POWERUP DLAY 30s</p> <p style="text-align: right;">PG↑ PG↓</p>	<p>HH: MM Screen Title Left/Right Arrow</p> <p>Delay in seconds when in Low Suction PSI Opening. Delay in seconds between valve adjustments. Time in seconds to hold the valve at the start % set point when the compressor starts. Delay in seconds to power up. Use left/right arrows to see time and type.</p> <p style="text-align: center;">Page up Page down</p>

Selecting the Page Down option provides the following:

<u>ACTUAL DISPLAY</u>	<u>DESCRIPTION</u>
<p>09: 56 Setpoints ◀ ▶</p> <p>Name Value</p> <p>25 STEP SENSIT 1</p> <p>26 STEP DELAY 300s</p> <p>27 MAX ROC- -0. 6P</p> <p>28 MAX ROC+ 0. 6p</p> <p style="text-align: right;">PG↑ PG↓</p>	<p>HH: MM Screen Title Left/Right Arrow</p> <p>This value is used to adjust the speed of responding to changes in the control algorithm. Time delay before increasing or decreasing the number of refrigeration steps. Maximum negative Rate Of Change allowed before stopping the unit from loading. Maximum positive Rate Of Change allowed before stopping the unit from unloading. Use left/right arrows to see time and type.</p> <p style="text-align: center;">Page up Page down</p>

Selecting the Page Down option provides the following:

<u>ACTUAL DISPLAY</u>	<u>DESCRIPTION</u>																							
<table border="0"> <tr> <td>09: 56 Setpoints</td> <td style="text-align: right;">◀ ▶</td> </tr> <tr> <td style="padding-left: 20px;">Name</td> <td style="padding-left: 100px;">Val ue</td> </tr> <tr> <td>29 ROC INTERVAL</td> <td style="text-align: right;">30s</td> </tr> <tr> <td>30 MAX SLIDE %</td> <td style="text-align: right;">100. 0%</td> </tr> <tr> <td>31 MIN SLIDE %</td> <td style="text-align: right;">55. 0%</td> </tr> <tr> <td>32 MAX ADJUST %</td> <td style="text-align: right;">5. 0%</td> </tr> <tr> <td style="text-align: center;">PG↑</td> <td style="text-align: center;">PG↓</td> </tr> </table>	09: 56 Setpoints	◀ ▶	Name	Val ue	29 ROC INTERVAL	30s	30 MAX SLIDE %	100. 0%	31 MIN SLIDE %	55. 0%	32 MAX ADJUST %	5. 0%	PG↑	PG↓	<table border="0"> <tr> <td>HH: MM</td> <td style="text-align: center;">Screen Title</td> <td style="text-align: right;">Left/Ri ght Arrow</td> </tr> <tr> <td colspan="3">Number of seconds between the samples used for calculating the actual Rate Of Change. Maximum slide or speed allowed. Minimum slide or speed allowed. Maximum percentage adjustment change that can be made. Use left/right arrows to see time and type.</td> </tr> <tr> <td colspan="2" style="text-align: center;">Page up</td> <td style="text-align: right;">Page down</td> </tr> </table>	HH: MM	Screen Title	Left/Ri ght Arrow	Number of seconds between the samples used for calculating the actual Rate Of Change. Maximum slide or speed allowed. Minimum slide or speed allowed. Maximum percentage adjustment change that can be made. Use left/right arrows to see time and type.			Page up		Page down
09: 56 Setpoints	◀ ▶																							
Name	Val ue																							
29 ROC INTERVAL	30s																							
30 MAX SLIDE %	100. 0%																							
31 MIN SLIDE %	55. 0%																							
32 MAX ADJUST %	5. 0%																							
PG↑	PG↓																							
HH: MM	Screen Title	Left/Ri ght Arrow																						
Number of seconds between the samples used for calculating the actual Rate Of Change. Maximum slide or speed allowed. Minimum slide or speed allowed. Maximum percentage adjustment change that can be made. Use left/right arrows to see time and type.																								
Page up		Page down																						

Selecting the Page Down option provides the following:

<u>ACTUAL DISPLAY</u>	<u>DESCRIPTION</u>																							
<table border="0"> <tr> <td>09: 56 Setpoints</td> <td style="text-align: right;">◀ ▶</td> </tr> <tr> <td style="padding-left: 20px;">Name</td> <td style="padding-left: 100px;">Val ue</td> </tr> <tr> <td>33 MIN ADJUST %</td> <td style="text-align: right;">2. 0%</td> </tr> <tr> <td>34 SLIDE SENSIT</td> <td style="text-align: right;">1</td> </tr> <tr> <td>35 AMP DB HI</td> <td style="text-align: right;">5. 0A</td> </tr> <tr> <td>36 AMP DB LO</td> <td style="text-align: right;">3. 0A</td> </tr> <tr> <td style="text-align: center;">PG☒</td> <td style="text-align: center;">PG☒</td> </tr> </table>	09: 56 Setpoints	◀ ▶	Name	Val ue	33 MIN ADJUST %	2. 0%	34 SLIDE SENSIT	1	35 AMP DB HI	5. 0A	36 AMP DB LO	3. 0A	PG☒	PG☒	<table border="0"> <tr> <td>HH: MM</td> <td style="text-align: center;">Screen Title</td> <td style="text-align: right;">Left/Ri ght Arrow</td> </tr> <tr> <td colspan="3">Minimum percentage change that can be made. Allows control of the adjustment made to slide wanted percentage. Upper dead band limit to stop pulsing the slide valve. Lower dead band limit to stop pulsing the slide valve. Use left/right arrows to see time and type.</td> </tr> <tr> <td colspan="2" style="text-align: center;">Page up</td> <td style="text-align: right;">Page down</td> </tr> </table>	HH: MM	Screen Title	Left/Ri ght Arrow	Minimum percentage change that can be made. Allows control of the adjustment made to slide wanted percentage. Upper dead band limit to stop pulsing the slide valve. Lower dead band limit to stop pulsing the slide valve. Use left/right arrows to see time and type.			Page up		Page down
09: 56 Setpoints	◀ ▶																							
Name	Val ue																							
33 MIN ADJUST %	2. 0%																							
34 SLIDE SENSIT	1																							
35 AMP DB HI	5. 0A																							
36 AMP DB LO	3. 0A																							
PG☒	PG☒																							
HH: MM	Screen Title	Left/Ri ght Arrow																						
Minimum percentage change that can be made. Allows control of the adjustment made to slide wanted percentage. Upper dead band limit to stop pulsing the slide valve. Lower dead band limit to stop pulsing the slide valve. Use left/right arrows to see time and type.																								
Page up		Page down																						

Selecting the Page Down option provides the following:

<u>ACTUAL DISPLAY</u>	<u>DESCRIPTION</u>																							
<table border="0"> <tr> <td>09: 56 Setpoints</td> <td style="text-align: right;">◀ ▶</td> </tr> <tr> <td style="padding-left: 20px;">Name</td> <td style="padding-left: 100px;">Val ue</td> </tr> <tr> <td>37 LOAD PULSE</td> <td style="text-align: right;">3</td> </tr> <tr> <td>38 UNLOAD PULSE</td> <td style="text-align: right;">2</td> </tr> <tr> <td>45 CND STG1 ON</td> <td style="text-align: right;">200. 0P</td> </tr> <tr> <td>46 CND STG1 OFF</td> <td style="text-align: right;">170. 0P</td> </tr> <tr> <td style="text-align: center;">PG☒</td> <td style="text-align: center;">PG☒</td> </tr> </table>	09: 56 Setpoints	◀ ▶	Name	Val ue	37 LOAD PULSE	3	38 UNLOAD PULSE	2	45 CND STG1 ON	200. 0P	46 CND STG1 OFF	170. 0P	PG☒	PG☒	<table border="0"> <tr> <td>HH: MM</td> <td style="text-align: center;">Screen Title</td> <td style="text-align: right;">Left/Ri ght Arrow</td> </tr> <tr> <td colspan="3">Length of time to turn on the slide valve load solenoid. Length of time to turn on the slide valve unloader solenoid. When the discharge pressure is above this value; turns on the first stage of the condenser fans. When the discharge pressure drops below this value turns off the first stage of condenser fans. Use left/right arrows to see time and type.</td> </tr> <tr> <td colspan="2" style="text-align: center;">Page up</td> <td style="text-align: right;">Page down</td> </tr> </table>	HH: MM	Screen Title	Left/Ri ght Arrow	Length of time to turn on the slide valve load solenoid. Length of time to turn on the slide valve unloader solenoid. When the discharge pressure is above this value; turns on the first stage of the condenser fans. When the discharge pressure drops below this value turns off the first stage of condenser fans. Use left/right arrows to see time and type.			Page up		Page down
09: 56 Setpoints	◀ ▶																							
Name	Val ue																							
37 LOAD PULSE	3																							
38 UNLOAD PULSE	2																							
45 CND STG1 ON	200. 0P																							
46 CND STG1 OFF	170. 0P																							
PG☒	PG☒																							
HH: MM	Screen Title	Left/Ri ght Arrow																						
Length of time to turn on the slide valve load solenoid. Length of time to turn on the slide valve unloader solenoid. When the discharge pressure is above this value; turns on the first stage of the condenser fans. When the discharge pressure drops below this value turns off the first stage of condenser fans. Use left/right arrows to see time and type.																								
Page up		Page down																						

Selecting the Page Down option provides the following:

<u>ACTUAL DISPLAY</u>	<u>DESCRIPTION</u>																							
<table border="0"> <tr> <td>09: 56 Setpoints</td> <td style="text-align: right;">◀ ▶</td> </tr> <tr> <td style="padding-left: 20px;">Name</td> <td style="padding-left: 100px;">Val ue</td> </tr> <tr> <td>47 CND DIFF ON</td> <td style="text-align: right;">5. 0P</td> </tr> <tr> <td>48 CND DIFF OFF</td> <td style="text-align: right;">2. 0P</td> </tr> <tr> <td>49 CND MIN RUN</td> <td style="text-align: right;">1m</td> </tr> <tr> <td>56 PULSE DELAY</td> <td style="text-align: right;">4s</td> </tr> <tr> <td style="text-align: center;">PG☒</td> <td style="text-align: center;">PG☒</td> </tr> </table>	09: 56 Setpoints	◀ ▶	Name	Val ue	47 CND DIFF ON	5. 0P	48 CND DIFF OFF	2. 0P	49 CND MIN RUN	1m	56 PULSE DELAY	4s	PG☒	PG☒	<table border="0"> <tr> <td>HH: MM</td> <td style="text-align: center;">Screen Title</td> <td style="text-align: right;">Left/Ri ght Arrow</td> </tr> <tr> <td colspan="3">Differential PSI to turn on the remaining stages of condenser fans. Differential PSI to turn off the remaining stages of condenser fans. Condenser fan will remain on for at least the amount of minutes specified. The number of seconds between load or unload pulses. Use left/right arrows to see time and type.</td> </tr> <tr> <td colspan="2" style="text-align: center;">Page up</td> <td style="text-align: right;">Page down</td> </tr> </table>	HH: MM	Screen Title	Left/Ri ght Arrow	Differential PSI to turn on the remaining stages of condenser fans. Differential PSI to turn off the remaining stages of condenser fans. Condenser fan will remain on for at least the amount of minutes specified. The number of seconds between load or unload pulses. Use left/right arrows to see time and type.			Page up		Page down
09: 56 Setpoints	◀ ▶																							
Name	Val ue																							
47 CND DIFF ON	5. 0P																							
48 CND DIFF OFF	2. 0P																							
49 CND MIN RUN	1m																							
56 PULSE DELAY	4s																							
PG☒	PG☒																							
HH: MM	Screen Title	Left/Ri ght Arrow																						
Differential PSI to turn on the remaining stages of condenser fans. Differential PSI to turn off the remaining stages of condenser fans. Condenser fan will remain on for at least the amount of minutes specified. The number of seconds between load or unload pulses. Use left/right arrows to see time and type.																								
Page up		Page down																						

<u>ACTUAL DISPLAY</u>	<u>DESCRIPTION</u>																							
<table border="0"> <tr> <td>09: 56 Setpoints</td> <td style="text-align: right;">◀ ▶</td> </tr> <tr> <td style="padding-left: 20px;">Name</td> <td style="padding-left: 100px;">Val ue</td> </tr> <tr> <td>59 ACYC OFF->ON</td> <td style="text-align: right;">60s</td> </tr> <tr> <td>61 PMP DWN OFF</td> <td style="text-align: right;">30. 0P</td> </tr> <tr> <td>62 PMP DWN DLAY</td> <td style="text-align: right;">20s</td> </tr> <tr> <td>63 ACYC ON->ON</td> <td style="text-align: right;">120s</td> </tr> <tr> <td style="text-align: center;">PG☒</td> <td style="text-align: center;">PG☒</td> </tr> </table>	09: 56 Setpoints	◀ ▶	Name	Val ue	59 ACYC OFF->ON	60s	61 PMP DWN OFF	30. 0P	62 PMP DWN DLAY	20s	63 ACYC ON->ON	120s	PG☒	PG☒	<table border="0"> <tr> <td>HH: MM</td> <td style="text-align: center;">Screen Title</td> <td style="text-align: right;">Left/Ri ght Arrow</td> </tr> <tr> <td colspan="3">Anti cycle time delay (in seconds) based on when the compressor was turned off. Suction pressure value for turning off the compressor when in the PUMP DOWN state. Maximum time delay (in seconds) that a compressor can remain in the PUMP DOWN state. Anti cycle time delay (in seconds) based on when the compressor was turned on. Use left/right arrows to see time and type.</td> </tr> <tr> <td colspan="2" style="text-align: center;">Page up</td> <td style="text-align: right;">Page down</td> </tr> </table>	HH: MM	Screen Title	Left/Ri ght Arrow	Anti cycle time delay (in seconds) based on when the compressor was turned off. Suction pressure value for turning off the compressor when in the PUMP DOWN state. Maximum time delay (in seconds) that a compressor can remain in the PUMP DOWN state. Anti cycle time delay (in seconds) based on when the compressor was turned on. Use left/right arrows to see time and type.			Page up		Page down
09: 56 Setpoints	◀ ▶																							
Name	Val ue																							
59 ACYC OFF->ON	60s																							
61 PMP DWN OFF	30. 0P																							
62 PMP DWN DLAY	20s																							
63 ACYC ON->ON	120s																							
PG☒	PG☒																							
HH: MM	Screen Title	Left/Ri ght Arrow																						
Anti cycle time delay (in seconds) based on when the compressor was turned off. Suction pressure value for turning off the compressor when in the PUMP DOWN state. Maximum time delay (in seconds) that a compressor can remain in the PUMP DOWN state. Anti cycle time delay (in seconds) based on when the compressor was turned on. Use left/right arrows to see time and type.																								
Page up		Page down																						

Selecting the Page Down option provides the following:

<u>ACTUAL DISPLAY</u>	<u>DESCRIPTION</u>																							
<table border="0"> <tr> <td>09: 56 Setpoints</td> <td style="text-align: center;">◀ ▶</td> </tr> <tr> <td>Name</td> <td style="text-align: center;">Val ue</td> </tr> <tr> <td>64 COMP MIN RUN</td> <td style="text-align: center;">0m</td> </tr> <tr> <td>65 FLA COMP#1</td> <td style="text-align: center;">96. 4A</td> </tr> <tr> <td>75 HI AMPS %</td> <td style="text-align: center;">115. 0%</td> </tr> <tr> <td>76 LO AMPS %</td> <td style="text-align: center;">20. 0%</td> </tr> <tr> <td style="text-align: right;">PG↓</td> <td style="text-align: left;">PG↑</td> </tr> </table>	09: 56 Setpoints	◀ ▶	Name	Val ue	64 COMP MIN RUN	0m	65 FLA COMP#1	96. 4A	75 HI AMPS %	115. 0%	76 LO AMPS %	20. 0%	PG↓	PG↑	<table border="0"> <tr> <td>HH: MM</td> <td style="text-align: center;">Screen Title</td> <td style="text-align: center;">Left/Ri ght Arrow</td> </tr> <tr> <td colspan="3">Minimum compressor run time (in minutes) once turned on. Full Load Amps for the compressor on circuit 1. Percentage of the FLA; it is used to create the high amp draw limit. Percentage of the FLA: it is used to create the low amp draw limit. Use left/right arrows to see time and type.</td> </tr> <tr> <td colspan="2" style="text-align: right;">Page up</td> <td style="text-align: left;">Page down</td> </tr> </table>	HH: MM	Screen Title	Left/Ri ght Arrow	Minimum compressor run time (in minutes) once turned on. Full Load Amps for the compressor on circuit 1. Percentage of the FLA; it is used to create the high amp draw limit. Percentage of the FLA: it is used to create the low amp draw limit. Use left/right arrows to see time and type.			Page up		Page down
09: 56 Setpoints	◀ ▶																							
Name	Val ue																							
64 COMP MIN RUN	0m																							
65 FLA COMP#1	96. 4A																							
75 HI AMPS %	115. 0%																							
76 LO AMPS %	20. 0%																							
PG↓	PG↑																							
HH: MM	Screen Title	Left/Ri ght Arrow																						
Minimum compressor run time (in minutes) once turned on. Full Load Amps for the compressor on circuit 1. Percentage of the FLA; it is used to create the high amp draw limit. Percentage of the FLA: it is used to create the low amp draw limit. Use left/right arrows to see time and type.																								
Page up		Page down																						

Selecting the Page Down option provides the following:

<u>ACTUAL DISPLAY</u>	<u>DESCRIPTION</u>																							
<table border="0"> <tr> <td>09: 56 Setpoints</td> <td style="text-align: center;">◀ ▶</td> </tr> <tr> <td>Name</td> <td style="text-align: center;">Val ue</td> </tr> <tr> <td>77 LOW SUCTION</td> <td style="text-align: center;">20. 0P</td> </tr> <tr> <td>78 LO SUCT UNLD</td> <td style="text-align: center;">2. 0P</td> </tr> <tr> <td>79 LO SUCT RELD</td> <td style="text-align: center;">4. 0P</td> </tr> <tr> <td>80 UNSAFE SUCT</td> <td style="text-align: center;">5. 0P</td> </tr> <tr> <td style="text-align: right;">PG↑</td> <td style="text-align: left;">PG↓</td> </tr> </table>	09: 56 Setpoints	◀ ▶	Name	Val ue	77 LOW SUCTION	20. 0P	78 LO SUCT UNLD	2. 0P	79 LO SUCT RELD	4. 0P	80 UNSAFE SUCT	5. 0P	PG↑	PG↓	<table border="0"> <tr> <td>HH: MM</td> <td style="text-align: center;">Screen Title</td> <td style="text-align: center;">Left/Ri ght Arrow</td> </tr> <tr> <td colspan="3">System checks for low suction pressure for each running compressor. Value to take corrective action before a low suction pressure safety occurs. Value to increase to until the compressor will return to normal control. System checks for low suction pressure that is unsafe for each running compressor. Use left/right arrows to see time and type.</td> </tr> <tr> <td colspan="2" style="text-align: right;">Page up</td> <td style="text-align: left;">Page down</td> </tr> </table>	HH: MM	Screen Title	Left/Ri ght Arrow	System checks for low suction pressure for each running compressor. Value to take corrective action before a low suction pressure safety occurs. Value to increase to until the compressor will return to normal control. System checks for low suction pressure that is unsafe for each running compressor. Use left/right arrows to see time and type.			Page up		Page down
09: 56 Setpoints	◀ ▶																							
Name	Val ue																							
77 LOW SUCTION	20. 0P																							
78 LO SUCT UNLD	2. 0P																							
79 LO SUCT RELD	4. 0P																							
80 UNSAFE SUCT	5. 0P																							
PG↑	PG↓																							
HH: MM	Screen Title	Left/Ri ght Arrow																						
System checks for low suction pressure for each running compressor. Value to take corrective action before a low suction pressure safety occurs. Value to increase to until the compressor will return to normal control. System checks for low suction pressure that is unsafe for each running compressor. Use left/right arrows to see time and type.																								
Page up		Page down																						

Selecting the Page Down option provides the following:

<u>ACTUAL DISPLAY</u>	<u>DESCRIPTION</u>																							
<table border="0"> <tr> <td>09: 56 Setpoints</td> <td style="text-align: center;">◀ ▶</td> </tr> <tr> <td>Name</td> <td style="text-align: center;">Val ue</td> </tr> <tr> <td>81 HI DISC PSI</td> <td style="text-align: center;">350. 0P</td> </tr> <tr> <td>82 HI DISC UNLD</td> <td style="text-align: center;">10. 0P</td> </tr> <tr> <td>83 HI DISC RELD</td> <td style="text-align: center;">30. 0P</td> </tr> <tr> <td>85 LO DISC PSI</td> <td style="text-align: center;">120. 0P</td> </tr> <tr> <td style="text-align: right;">PG↑</td> <td style="text-align: left;">PG↓</td> </tr> </table>	09: 56 Setpoints	◀ ▶	Name	Val ue	81 HI DISC PSI	350. 0P	82 HI DISC UNLD	10. 0P	83 HI DISC RELD	30. 0P	85 LO DISC PSI	120. 0P	PG↑	PG↓	<table border="0"> <tr> <td>HH: MM</td> <td style="text-align: center;">Screen Title</td> <td style="text-align: center;">Left/Ri ght Arrow</td> </tr> <tr> <td colspan="3">High discharge pressure condition for each running compressor. Value to take corrective action before a high discharge pressure safety occurs. Value to reload high discharge pressure. Low discharge pressure compared to the sensor reading to this value. Use left/right arrows to see time and type.</td> </tr> <tr> <td colspan="2" style="text-align: right;">Page up</td> <td style="text-align: left;">Page down</td> </tr> </table>	HH: MM	Screen Title	Left/Ri ght Arrow	High discharge pressure condition for each running compressor. Value to take corrective action before a high discharge pressure safety occurs. Value to reload high discharge pressure. Low discharge pressure compared to the sensor reading to this value. Use left/right arrows to see time and type.			Page up		Page down
09: 56 Setpoints	◀ ▶																							
Name	Val ue																							
81 HI DISC PSI	350. 0P																							
82 HI DISC UNLD	10. 0P																							
83 HI DISC RELD	30. 0P																							
85 LO DISC PSI	120. 0P																							
PG↑	PG↓																							
HH: MM	Screen Title	Left/Ri ght Arrow																						
High discharge pressure condition for each running compressor. Value to take corrective action before a high discharge pressure safety occurs. Value to reload high discharge pressure. Low discharge pressure compared to the sensor reading to this value. Use left/right arrows to see time and type.																								
Page up		Page down																						

Selecting the Page Down option provides the following:

<u>ACTUAL DISPLAY</u>	<u>DESCRIPTION</u>																							
<table border="0"> <tr> <td>09: 56 Setpoints</td> <td style="text-align: center;">◀ ▶</td> </tr> <tr> <td>Name</td> <td style="text-align: center;">Val ue</td> </tr> <tr> <td>87 HI DISCH TMP</td> <td style="text-align: center;">215. 0F</td> </tr> <tr> <td>88 HI DISC UNLD</td> <td style="text-align: center;">2. 0F</td> </tr> <tr> <td>89 HI DISC RELD</td> <td style="text-align: center;">5. 0F</td> </tr> <tr> <td>91 LOW OIL DIF</td> <td style="text-align: center;">70. 0P</td> </tr> <tr> <td style="text-align: right;">PG↑</td> <td style="text-align: left;">PG↓</td> </tr> </table>	09: 56 Setpoints	◀ ▶	Name	Val ue	87 HI DISCH TMP	215. 0F	88 HI DISC UNLD	2. 0F	89 HI DISC RELD	5. 0F	91 LOW OIL DIF	70. 0P	PG↑	PG↓	<table border="0"> <tr> <td>HH: MM</td> <td style="text-align: center;">Screen Title</td> <td style="text-align: center;">Left/Ri ght Arrow</td> </tr> <tr> <td colspan="3">High discharge temperature condition for each circuit that has at least one step on. Value to take corrective action before a high discharge temperature safety occurs. Value to reload high discharge temperature. Low differential oil pressure compared to the calculated differential oil value. Use left/right arrows to see time and type.</td> </tr> <tr> <td colspan="2" style="text-align: right;">Page up</td> <td style="text-align: left;">Page down</td> </tr> </table>	HH: MM	Screen Title	Left/Ri ght Arrow	High discharge temperature condition for each circuit that has at least one step on. Value to take corrective action before a high discharge temperature safety occurs. Value to reload high discharge temperature. Low differential oil pressure compared to the calculated differential oil value. Use left/right arrows to see time and type.			Page up		Page down
09: 56 Setpoints	◀ ▶																							
Name	Val ue																							
87 HI DISCH TMP	215. 0F																							
88 HI DISC UNLD	2. 0F																							
89 HI DISC RELD	5. 0F																							
91 LOW OIL DIF	70. 0P																							
PG↑	PG↓																							
HH: MM	Screen Title	Left/Ri ght Arrow																						
High discharge temperature condition for each circuit that has at least one step on. Value to take corrective action before a high discharge temperature safety occurs. Value to reload high discharge temperature. Low differential oil pressure compared to the calculated differential oil value. Use left/right arrows to see time and type.																								
Page up		Page down																						

Selecting the Page Down option provides the following:

<u>ACTUAL DISPLAY</u>	<u>DESCRIPTION</u>																							
<table border="0"> <tr> <td>09: 56 Setpoints</td> <td style="text-align: center;">◀ ▶</td> </tr> <tr> <td>Name</td> <td style="text-align: center;">Val ue</td> </tr> <tr> <td>92 UNSAFE OIL</td> <td style="text-align: center;">20. 0P</td> </tr> <tr> <td>95 MOTOR FAULT</td> <td style="text-align: center;">0</td> </tr> <tr> <td>97 DirtyOilFltr</td> <td style="text-align: center;">50. 0P</td> </tr> <tr> <td>101SAFETY HOLD</td> <td style="text-align: center;">90s</td> </tr> <tr> <td style="text-align: right;">PG↑</td> <td style="text-align: left;">PG↓</td> </tr> </table>	09: 56 Setpoints	◀ ▶	Name	Val ue	92 UNSAFE OIL	20. 0P	95 MOTOR FAULT	0	97 DirtyOilFltr	50. 0P	101SAFETY HOLD	90s	PG↑	PG↓	<table border="0"> <tr> <td>HH: MM</td> <td style="text-align: center;">Screen Title</td> <td style="text-align: center;">Left/Ri ght Arrow</td> </tr> <tr> <td colspan="3">System checks for low differential oil pressure compared to the calculated differential oil pressure. System checks for high motor temperature compared to the sensor reading. Pressure indicating a dirty oil filter (discharge minus the oil filter pressure). Time (in seconds) to hold before trying to reload when avoiding a safety. Use left/right arrows to see time and type.</td> </tr> <tr> <td colspan="2" style="text-align: right;">Page up</td> <td style="text-align: left;">Page down</td> </tr> </table>	HH: MM	Screen Title	Left/Ri ght Arrow	System checks for low differential oil pressure compared to the calculated differential oil pressure. System checks for high motor temperature compared to the sensor reading. Pressure indicating a dirty oil filter (discharge minus the oil filter pressure). Time (in seconds) to hold before trying to reload when avoiding a safety. Use left/right arrows to see time and type.			Page up		Page down
09: 56 Setpoints	◀ ▶																							
Name	Val ue																							
92 UNSAFE OIL	20. 0P																							
95 MOTOR FAULT	0																							
97 DirtyOilFltr	50. 0P																							
101SAFETY HOLD	90s																							
PG↑	PG↓																							
HH: MM	Screen Title	Left/Ri ght Arrow																						
System checks for low differential oil pressure compared to the calculated differential oil pressure. System checks for high motor temperature compared to the sensor reading. Pressure indicating a dirty oil filter (discharge minus the oil filter pressure). Time (in seconds) to hold before trying to reload when avoiding a safety. Use left/right arrows to see time and type.																								
Page up		Page down																						

Selecting the Page Down option provides the following:

<u>ACTUAL DISPLAY</u>	<u>DESCRIPTION</u>
<pre> 09: 56 Setpoi nts ◀ ▶ Name Value 103LEAD COMP 1 104CMP ROTATI ON 7D 111FREEZE 14. 0F 113EXV START1% 15. 0% PG↑ PG↓ </pre>	<pre> HH: MM Screen Title Left/Ri ght Arrow Identifies the lead compressor. Specifies the number of days between rotations. Temperature indicated for freeze protection. Starting % which the valve will be opened to after the pump down state. Use left/right arrows to see time and type. Page up Page down </pre>

15.9. Service Tools

Selecting the 'Service Tools' option provides the following:

<u>ACTUAL DISPLAY</u>	<u>DESCRIPTION</u>
<pre> 09: 56 Serv Tools 1 Netwk Address 0 2 System Info 3 Time/Date 4 Di splay 5 Clr Alarm Hi st Help </pre>	<pre> HH: MM Screen Title Highlight choice and press enter to access Sub Menu. 1. View network address press enter. 2. View system info (config name, company name, model name) press enter. 3. To change the time or date press enter and use the up/down arrows to adjust. 4. View display settings (contrast, background, backlight) press enter. 5. To clear the alarm history press enter and save. </pre>

Pressing the down arrow provides the following:

<u>ACTUAL DISPLAY</u>	<u>DESCRIPTION</u>
<pre> 09: 56 Serv Tools 6 Clr Point Info 7 Sensor Diagnosti cs Help </pre>	<pre> HH: MM Screen Title Highlight choice and press enter to access Sub Menu. 6. To clear the point information press enter and save. 7. View sensor values and voltages. Page Up/Down for more sensors. Press the Back button to return to the Service Tools Main Menu. </pre>

Chapter - 16. Control Status Display

16.1. From the MCS-Connect program

Capacity Control State	Time	Wanted/ Actual	Step Delay	Def. App.(Air) /Def. Time(Air)	Def. App.(Backup) /Def. Time(Backup)	Rate of Change	Control On	Wanted %		
RUN/STOP SW OFF	194:25:55	0/0	120	N/A	30.0P / 00:04:00	0.0	VOLTAGE	N/A		
State	Time	PSI Diff	FLA %	Forced Defrost Delay(145)	Lead?	Manual FLA %				
1-1)CMP OFF/READY	195:36:27	130.0P	100%	18:00:00		N/A				
2-1)CMP OFF/READY	195:36:27	130.0P	100%	18:00:00	Yes	N/A				
3-1)CMP OFF/READY	195:36:27	130.0P	100%	18:00:00		N/A				
Evap EXV State	Time	Valve %	Control On Suct. Supht	SuperHeat ROC	ADJ Delay	EXV Target (Adjusted)	Sat Evap.	Evap. App.(Air) /Time (Air)	Evap. Approach /Time	Evap. Superheat
1-1) EXV IS CLOSED	194:25:56	0.0%	6.5	0.0	0	11.0F	33.5	N/A	6.5F / 00:02:00	6.5
1-2) EXV IS CLOSED	194:25:56	0.0%	6.5	0.0	0	11.0F	33.5	N/A	6.5F / 00:02:00	6.5
2-1) EXV IS CLOSED	194:25:56	0.0%	6.5	0.0	0	11.0F	33.5	N/A	6.5F / 00:02:00	6.5
2-2) EXV IS CLOSED	194:25:56	0.0%	6.5	0.0	0	11.0F	33.5	N/A	6.5F / 00:02:00	6.5
3-1) EXV IS CLOSED	194:25:56	0.0%	6.5	0.0	0	11.0F	33.5	N/A	6.5F / 00:02:00	6.5
3-2) EXV IS CLOSED	194:25:56	0.0%	6.5	0.0	0	11.0F	33.5	N/A	6.5F / 00:02:00	6.5
Suction Temp	Saturated Suction	Suction Superheat	Disc Temp	Saturated Discharge	Disc Superheat	Ref Type	Defrost Min Delay(130)			
41.50.0	33.5	46.5	40.0	85.0	40.0	R407A	00:10:00			

The status of both the CAPACITY CONTROL STATES and CIRCUIT CONTROL STATES can be viewed from the MCS-Connect program by accessing the CONTROL STATUS key under status screen. The following will be displayed:

Use your arrow keys to access all information (Active circuits will be displayed)

16.1.1 Information displayed:

Chiller information:

- CAPACITY CONTROL STATE - State of chiller
- TIME - time in that state, if the state is UNIT IN POWER UP time will decrement to zero
- STEPS WANTED - Number of steps wanted on
- ACTUAL - actual steps turned on
- STEP DELAY – value that is counted down. The sensitivity and where the control temperature is in relationship to the control zone will determine the speed of the count down. When the value decrements to zero, the system will determine if a change in the system’s capacity is required.
- Def. Approach/Def Time – defrost trigger is the value in of the associated approach set point, if evaporator pressure is below this value the timer will begin to decrement. When it reaches 0, a hot gas defrost will be required.
- RATE OF CHANGE – Rate of Change of control temperature, the speed at which the control temperature is changing.
- Control On– this will indicated either VOLTAGE or TEMPERATURE.
- Wanted % – if a screw compressor the value will be the slide wanted.

Circuit information (all active circuits will be displayed):

- # - circuit number.
- STATE -compressor state.
- TIME - time in that state, if the state is CMP ANTICYCLE time will decrement to zero.
- PSI DIFF - Oil differential pressure. Oil differential pressure is calculated as follows:

Hitachi, Hartford, & Hanbell screw compressor:

Discharge minus Suction Pressure;

Carlyle screw compressor:

Discharge minus Oil Pressure;

NOT a screw and Not a Bitzer screw compressor:

Oil minus Suction Pressure

All Others

Oil minus Discharge Pressure.

- **Sat Evap** – this is the saturation evaporation temperature.
- **Evap Trigger / Time** – this is the evaporation pressure / time will decrement when the evaporation pressure is less than the trigger pressure value.
- **EvapSuperheat** – Calculated evaporation SUPERHEAT.
- **FLA %** – reflexes the amp draw of the compressor.
- **Forced Delay (145) Defrost** – this is the time remaining until the next defrost is forced to begin.
- **LEAD** - Yes indicates the lead compressor.

LLS State (status of the liquid line & tandem liquid line if they exist)

- **LLS State**- Status of the LLS.
- **Time**- Time in the state indicated.

Circuit SUPERHEAT– information (all active circuits will be displayed):

- **Suction Temp** – Circuit number and current value of the Suction Temperature, if available.
- **Saturated Suction**– Calculated Suction Saturated Temperature, if available. The Suction Pressure is converted into temperature based upon the type of refrigerant (R22, R134a, R407c, And R410a are supported).
- **Suction Superheat** – Calculated Suction SUPERHEAT, only available if both the Suction Temperature and the Suction Pressure are used. The calculation is Suction Temperature minus the Suction Saturated Temperature.
- **Disc Temp** – Discharge Temperature, if available.
- **Saturated Discharge**– Calculated Discharge Saturated Temperature, if available. The Discharge Pressure is converted into temperature based upon the type of refrigerant (R22, R134a, R407c, And R410a are supported).
- **Disc Superheat** – Calculated Discharge SUPERHEAT, only available if both the Discharge Temperature and the Discharge Pressure are used. The calculation is Discharge Temperature minus the Discharge Saturated Temperature.
- **Refr Type is** –Indicates the type of refrigerant in the system.
- **Defrost Min Delay (130)** –when the circuit is not in defrost this timer will be decremented. It is the minimum time between defrost cycles based upon set point #130

Chapter - 17. Magnum Control States

We should consider the Magnum controller as a state computer, that is, decisions are made based upon set points, timers and sensor inputs, the controller moves from one state to another. The controller will change states to ensure the proper functioning of the chiller package.

As we review the various states, we must remember that a chiller package consists of a number of different parts or functions: the compressors and their related items such as unloaders hot gas bypasses, etc.; evaporator; and condensing functions. To control these functions the states will be divided into three sections:

- Capacity Control States
- Circuit Control States
- Condenser Control States

This information can be viewed from the Magnum's display, see section Magnum Displays or from MCS-Connect, see section MCS-Connect Status.

Chapter - 18. Capacity Control States (number)

The Magnum controller is a state computer, that is, decisions are made based upon Set points, timers and Sensor Inputs, the controller moves from one state to another. The controller will change states to ensure the proper functioning of the chiller package.

As we review the various states, we must remember that a chiller package consists of a number of different parts or functions: the compressors and their related items such as unloaders, hot gas bypasses, etc.; evaporator, and condensing functions.

Both the Capacity Control States and Compressor Control States are displayed in the Status screens on the Keypad Display. To view the state of the chiller, select the Status option from the menu on the Keypad. You can then view the entire status by using the page up / down function keys. The information can also be accessed through MCS-Connect under status screen by clicking on the CONTROL STATUS button.

Unit Control State (number)

Note: All User Logic points can now access the Unit Control State. The value accessed is the number listed in parenthesis in the following headings.

18.1. UNIT IN POWER UP (0)

This state is entered when the Magnum is powered up or the system has been reset. The system will remain in this state for the time specified in Set point #23 "POWER DELAY" or for 60 seconds if not active. In this state all Relay Outputs are turned off. This time delay is to insure the microprocessor has stable power before starting the algorithm.

18.2. POWER LOSS DELAY (1)

This state is entered when the Magnum has been powered off for greater than 2 hours. In this state all points (RO's) are turned off. The system will remain in this state for the time specified in set point #23, PWR OFF DLAY.

18.3. NO RUN- I/O LOST (2)

This state will be entered whenever the Magnum loses communications with any of the I/O boards that are connected through the MCS I/O network. When this state is entered the Magnum will generate an MCS I/O offline alarm, which identifies which I/O is offline and a lost I/O shutdown alarm which locks out the unit. Once locked out, if there are ten consecutive successful I/O reads the Magnum will reset and attempt to run. When this occurs a "LOST I/O RESTART" will be generated. Or, the lockout-reset key can be pressed to reset the Magnum, after the lost I/O has been corrected. This will generate a "LOCKOUT RESET." In this state all RO's except ALARM are turned OFF.

18.4. UNIT IN LOCKOUT (3)

This state is entered whenever a critical situation is encountered that could cause harm to the chiller package. Items such as freeze protect and emergency stop will force the system into this state. Lockouts can be reset without authorization from the keypad or MCS-Connect program; however if the lockout condition has not been corrected, the system will again be forced into the LOCKOUT state. In this state, all RO's except ALARM and OIL HEATER (for screws with an oil pump) are turned OFF and placed in the "LOCKOUT" state. Note: If the Lockout Reset is pressed more than the programmed allowable number of times in one day the unit cannot be reset during the current day except through MCS-Connect and

A Factory authorization is required. This number is selected from a drop down menu under the Setup Information button, with a range of 2 to 12.

18.5. UNIT IS OFF (4)

This state is entered when the system has finished a STARTUP, DISABLE, LOCKOUT, or NO RUN- I/O LOST state. The chiller is now ready to move into an active state to meet the capacity required.

18.6. UNIT IS HOLDING (5)

This state is entered when one of three conditions exists:

- 1) The control sensor reading is being maintained within the control zone.
- 2) Control sensor reading is above the control zone but the Rate of Change is less than the value in the (MAX ROC-, #27) set point. This indicates that the temperature is decreasing toward the target at an acceptable speed. Therefore, no additional cooling is needed at this time.
- 3) The temperature is below the control zone but the Rate of Change is greater than the (MAX ROC+, #28) set point. This indicates that the temperature is increasing toward the target. Therefore, no reduction in cooling is needed at this time.

This state indicates that there is no need to add or subtract the cooling capacity of the chiller package. This state will change as capacity requirement changes.

18.7. UNIT UNLOADING (6)

This state is entered when less capacity is required. Every second an adjustment is made to the step delay. When the delay reaches zero, the counter 'steps wanted' on is decreased by 1.

18.8. UNIT IS LOADING (7)

This state is entered when more capacity is required. Every second an adjustment is made to the step delay. When the delay reaches zero, the counter 'steps wanted on' is increased by 1.

18.9. CMP IN STARTU (8)

When a fixed step compressor with variable speed (VFD) capabilities is started this stage is entered. The Relay Status for the compressor point must be setup with the 'VFD Start %' and the 'VFD Start % Time'. If these fields are not valid then this step is bypassed. The compressor will remain in this state for the time specified and the associated analog output (VFD) will be set to the start %.

18.10. RUN/STOP SW OFF (9)

This state is entered when the run stop switch is off, in the stop position. When the chiller is in this state, the individual compressor states if active are moved to the CMP IS OFF state through the normal states. One capacity STEP will be moved per second.

18.11. SCHEDULED OFF (10)

This state is entered when the schedule is calling for the package to be off. When the chiller is in this state, the individual circuit states if active are moved to the CMP IS OFF state through the normal states. One capacity STEP will be moved per second.

18.12. OFF- NO FLOW(s) (11)

This state is entered when the evaporator flow switch is off. When the chiller is in this state, the individual circuit states if active are moved to the CMP IS OFF state through the normal states. One capacity STEP will be moved per second. If the NO FLOW Set point is active and set to Lockout the chiller will lockout on no flow.

18.13. NOT USED (12)

18.14. NOT USED (13)

18.15. NOT USED (14)

18.16. UNIT IS UNLOADED (15)

This state is entered when all of the systems available capacity steps are off. The package is providing no cooling capacity, as none is required. The system is ready to react to cooling needs.

18.17. UNIT IS LOADED (16)

This state is entered when all of the systems available capacity steps are on. The package is providing the maximum amount of cooling capacity.

18.18. NOT USED (17)

18.19. NOT USED (18)

18.20. NOT USED (19)

18.21. DEF-STARTING CMP (20) (only used if not Air Normal Defrost)

This state is entered when a capacity steps has indicated a need for defrosting. The system will remain in this state until the defrosting circuits discharge pressure is less than the value in set point #141, DEF Min PSI or the time in this state is greater than the value in set point #142.

18.22. DEFROSTING COILS (21) (only used if not Air Normal Defrost)

This state is entered when the defrosting circuits discharge pressure is less than the value in set point #139, DEF Min PSI. The system will remain in this state until the defrosting function has been completed.

18.23. LO TEMP UNLOAD (22)

The following two conditions can cause this state to be entered and the system to begin unloading this compressor:

- 1) The evaporator temperature is within 1.5F or .8C of the value of set point #95, FREEZE PROTECT.
- 2) The refrigerant temperature is less than the value of set point #155, LOW REFR TEMP and this set point is active.

Chapter - 19. Circuit Control States (number)

Note: All User Logic points can now access the Unit Control State. The value accessed is the number listed in parenthesis in the following headings.

The action of the circuit control states actually result in more, less or no change in the amount of cooling capacity. The CAPACITY CONTROL STATES dictate how the individual circuits move within their states.

19.1. LOST IO LOCKED (0)

This state is entered when the Capacity Control State is NO RUN- I/O LOST. Resetting the lockout will move the compressor to the CMP OFF/READY state.

19.2. CMP LOCKED OUT (1)

This state is entered when the Capacity Control State is in UNIT IN LOCKOUT or a safety trip has occurred for this compressor (Examples of safety Set points include #69 "LOW SUCTION" and #79 "HI DISC PSI"). Lockouts can be reset without authorization from the keypad or MCS-Connect program, however if the condition causing the lockout has not been corrected, the compressor will again be forced into the LOCKOUT State.

19.3. SWITCHED OFF (2)

This state is entered when the compressor is off due to the pump down switch being on or the compressor flow switch being off. In this state the compressor and all related points, including the liquid line solenoid are off. The compressor will not leave this state unless the pump down switch is turned off. If the pump down switch is turned off, the compressor state will be changed to the CMP OFF/READY state.

19.4. UNLD & PMPDWN (3)

This state is entered whenever the pump down switch has been turned on or if this circuit is no longer wanted on. The compressor is on and the liquid line solenoid is closed. This state is active until the suction pressure reaches the value in the set point #62, PMP DWN OFF or the time has exceeded the value in the set point# 63, PMP DWN DELY. The circuit will then move to the ANTICYC State.

19.5. CMP ANTICYCE (4)

This state is entered when the UNLD and PMPDWN state has been completed. The compressor will stay in this state with all compressor points off for the period of time contained in set point #59 "ACYC OFF-> ON" or set point #60 "ACYC ON -> ON", whichever is longer. The compressor will then move to the OFF state. NOTE: "ACYC ON -> ON" can be used to set the maximum number of compressor starts per hour.

19.6. CMP OFF/READY (5)

This state is entered when no capacity is required from this compressor, or the last state was CMP ANTICYCE, LOST I/O LOCKED, or SWITCHED OFF. In this state the compressor is ready to provide capacity if needed. The compressor will remain in this state for a minimum of 60 seconds.

19.7. NOT USED (6)

19.8. NOT USED (7)

19.9. CMP UNLOADED (8)

For infinite step compressors, this state is when the slide is fully unloaded (indicated by unloaded input or after the unloader is pulsed 30 seconds with no change). For fixed step compressors, this state is when the compressor is on and fully unloaded. In this state the compressor is supplying its minimum cooling capacity.

19.10. CMP UNLD STEP1 (9)

This state only applies for fixed step capacity compressors with a Hot Gas Bypass solenoid. In this state the Hot Gas Bypass solenoid is off and all unloaders in the compressor are on.

19.11. CMP UNLD STEP2 (10)

This state only applies for fixed step compressors with two unloaders. This state occurs when the Hot Gas Bypass solenoid, if present, is off, the first unloader solenoid is off, and the second unloader solenoid is on.

19.12. CMP IS HOLDING (11)

This state only applies for variable step compressors. In this state, the required refrigeration capacity of system is being met; no movement of the slide valve is required.

19.13. CMP IS LOADING (12)

For variable step compressors, this state occurs when the load solenoid is being pulsed to increase the capacity of the compressor. The duration of the pulse is specified in the set point #35 "LOAD PULSE" and the frequency of the pulse is determined by set point #165 "PULSE DELAY". The set point "PULSE DELAY" should be a value of between 3 and 5 seconds to allow the amp sensor to reflect the change.

19.14. CMP IS UNLDING (13)

For variable step compressors, this state is when the unload solenoid is being pulsed to reduce the capacity of the compressor. The duration of the pulse is specified in setpoint #36 "UNLOAD PULSE" and the frequency of the pulse is determined by setpoint #165 "PULSE DELAY". The setpoint "PULSE DELAY" should be a value of between 3 and 5 seconds to allow the refrigerant to enter the chamber slowly enough to not cause oil foaming.

19.15. CMP IS RUNNING (14)

For fixed capacity compressors only, this state occurs when the compressor is fully loaded. In this state, the compressor is providing the maximum amount of cooling capacity.

19.16. FAST UNLOADING (15)

For screw compressors only, this state is entered when the compressor is turned on. All load solenoids will be turned off and all unload solenoids will be turned on to ensure the screw is fully unloaded. If an oil pump is included in the system it will be turned on during this state. The system will remain in this state for 30-seconds, the state will then be changed to HOLDING.

19.17. LO SUCT UNLOAD (16)

Refer to Set points #69 "LOW SUCTION"; #70 "LO SUCT UNLD"; and #71 "LO SUCT RELD".

For variable step compressors only. The capacity is being unloaded due to low suction pressure. The compressor will stay in this state until the suction pressure is above Setpoint #79 "LO SUCT RELD". The system will then move to the LO SUCT HOLD state.

19.18. LO SUCT HOLD (17)

Refer to setpoints #69 "LOW SUCTION"; #70 "LO SUCT UNLD"; and #71 "LO SUCT RELD".

Fixed step compressors - This state is entered when a fully loaded compressor that has more than one step is unloading due to low suction pressure. One step of capacity is turned off. The compressor will remain in this state for a minimum of five minutes before returning to the LOADED state if the low suction condition has been corrected.

Variable Step Compressors - Capacity is being held due to low suction pressure. Once the suction pressure returns to a normal operating level the compressor will return to its normal running state.

19.19. HI DISC UNLOAD (18)

Refer to setpoints #73 "HI DISC PSI"; #74 "HI DISC UNLD"; #75 "HI DISC RELD"; #79 "HI DISC TMP"; #80 "HI DISC UNLD"; and #81 "HI DISC RELD".

Fixed Step Compressors - This state is entered when a fully loaded compressor that has more than one step is unloading due to high discharge pressure or temperature. One step of capacity will be turned off. The compressor will remain in this state for a minimum of five minutes before returning to the LOADED state if the high discharge condition has been corrected.

Variable Step Compressors - Capacity is being held due to high discharge temperature or pressure. Once the discharge returns to normal operating levels the compressor will return to its normal running state.

19.20. HI DISC HOLD (19)

Refer to Setpoints #73 "HI DISC PSI"; #74 "HI DISC UNLD"; #75 "HI DISC RELD"; #79 "HI DISC TMP"; #880 "HI DISC UNLD"; and #81 "HI DISC RELD".

Fixed Step Compressors—This state is entered when a fully loaded compressor that has more than one step is unloading due to high discharge pressure or temperature. One step of capacity will be turned off. The compressor will remain in this state for a minimum of five minutes before returning to the LOADED state if the high discharge condition has been corrected.

Variable Step Compressors—Capacity is being held due to high discharge temperature or pressure. Once the discharge returns to normal operating levels the compressor will return to its normal running state.

19.21. SAFETY TRIPPED (20)

This state is entered when a safety trips but a lockout is not to be generated. An alarm is generated but the system will restart after the delay specified in the corresponding set point. If a second trip occurs within the time specified in the set point, the circuit will be placed in the CMP LOCK EDOUT State.

19.22. NOT USED (21)

19.23. HI AMP UNLDING (22)

For variable step compressors this state is entered when the amp draw is greater than the respective FLA setpoint plus half the value in setpoint #191, "HI AMPS". This action is to prevent a high amps safety trip from occurring. Once the amp draw has been reduced the system state will change to HI AMP HOLD.

19.24. HI AMP HOLD (23)

Not used with infinite step compressors. This state is entered when a fully loaded circuit, that has more than one step, has encountered a dangerously high AMP draw. Refer to set points numbers 171 through 190 for FLA per circuit and 191 HI AMPS %. In this state, one step of cooling capacity will be turned off. The circuit will remain in this state for a minimum of five minutes before returning to the LOADED State if the dangerous condition has been corrected

19.25. HI DIS TMP HLD (24)

Refer to setpoints #79 "HI DISC TMP"; #80 "HI DISC UNLD"; and #81 "HI DISC RELD".

This state is entered when a fully loaded compressor that has more than one step encounters a high discharge temperature. One step of capacity will be turned off. The compressor will then remain in this state for a minimum of five minutes before returning to the LOADED state if the high discharge temperature has returned to normal.

19.26. NOT USED (25)

19.27. NOT USED (26)

19.28. HI WATER HOLD (27)

When the compressor is running and set point #78 "HI RETURN TEMP" is active, the Magnum will check for high water temperature. If the control temperature is greater than set point #86 for the time specified the Magnum will place the compressor in this state. The system will be unable to load when in this state.

19.29. DEFROST EVAP1 (28) (not Rotating Coil Air Defrost Only)

The circuit's first evaporator is being defrosted. Refer to the section on circuit defrost and to the sequence of operations for the various software versions.

19.30. DRIP DOWN #1 (29) (not Rotating Coil Air Defrost Only)

The circuit's first evaporator has completed its defrost cycle and moisture is allowed to drip off the coils before cooling begins. Refer to the section on circuit defrost and to the sequence of operations for the various software versions.

19.31. DEFROSTR EVAP2 (30) (not Rotating Coil Air Defrost Only)

The circuit's second evaporator is being defrosted. Refer to the section on circuit defrost and to the sequence of operations for the various software versions.

19.32. DRIP DOWN #2 (31) (not Rotating Coil Air Defrost Only)

The circuit's second evaporator has completed its defrost cycle and moisture is allowed to drip off the coils before cooling begins. Refer to the section on circuit defrost and to the sequence of operations for the various software versions.

19.33. DEF-START CMP (32) (not Rotating Coil Air Defrost Only)

Once one of the circuits is ready for defrost: The circuit that is ready to begin a defrost cycle it will then be placed in the DEF-PUMP DOWN state. If the circuit is not ready for a defrost cycle it will be turned off.

19.34. DEF-PUMP DOWN (33)

This state is only used when the defrost type is either Electric or Time Off. In this state the compressor will be on and the liquid line solenoid will be closed. The circuit will remain in this state until the suction pressure is less than the value in set point #62 PMP DWN OFF or the time in set point #63, PMP DWN DELY has been exceeded. The circuit will then be placed in the DEFROST COIL state.

In this state the compressor will be on and the liquid line solenoid will be closed. The circuit will remain in this state until the suction pressure is less than the value in set point #142 DEF PDWN PSI or the time in set point #141, DEF PDWN TIM has been exceeded. The circuit will then be placed in the DEFROST COIL state.

19.35. DEFROST COILS (34)

This state is only used when the defrost type is either Electric or Time Off. In this state the compressor will be off and the liquid line solenoid will be closed. If the defrost type is Electric, the electric defrost relay output will be turned on. The circuit will remain in this state until evaporator temperature is greater than the value in set point indicated by the approach temperature or the time has been exceeded. The circuit will then be placed in the DRIP DOWN #1 state.

In this state the compressor will be off and the liquid line solenoid will be closed. The circuit will remain in this state until evaporator temperature is greater than the value in set point indicated by the approach temperature or the time has been exceeded or the discharge pressure is less than the value in set point #144, DEF TERMIN P. If this is not the last circuit running, the circuit will be turned off. If it is the last circuit running, the circuit will remain on and the system will return to normal operations.

19.36. DEF-AIR NORMAL (35)

This state is entered when the circuit entering defrost is in the time frame specified by setpoint #245.

19.37. NOT USED (36)

19.38. CMP OFF/D-DOWN (37)

This state is entered after the hot gas defrost cycle has been completed include the pump down period. The system will remain in this state for time specified in set point #132, this will complete the defrosting cycle. The state will then be changed to CMP OFF/READY.

19.39. CMP OFF/DefAIR (38) (only used if Air Defrost)

This state will be displayed for the compressor that has entered into an Air Defrost, after the time in setpoint #245 has expired.

19.40. DEFcmp&val OFF (39)

When the system is in a reverse cycle defrost, this state shuts off both the compressor and reversing valve for the time in value of set point #165.

19.41. LO TEMP HOLD (40)

Reload from the "LO TMP UNLOAD" occurs when the evaporator temperature is 3.0° F (1.6C) above Setpoint #95, FREEZE PROTECT and the refrigerant temperature sensor, if present, is greater than Setpoint #155 "LO REF TMP" plus twice the value Setpoint #156 "LO REF TMP". Until this temperature is reached the system will remain in the LO TMP HOLD State.

19.42. HI TEMP UNLOAD (41)

The system will unload if Setpoint #107 "HP OVERHEAT" is active and the leaving temperature is greater than the value in Setpoint #107 minus 1.5°F (.8°C). The compressor will then move to the HI TEMP HOLD state when the temperature drops below the value in Setpoint #107 minus 3.0°F (1.6°C).

19.43. HI TEMP HOLD (42)

Refer to HI TEMP UNLOAD state. The compressor will state in this state until the temperature drops below Setpoint #107 minus 3.0°F (1.6°C) the compressor will return to a normal state.

Chapter - 20. Condenser Control Logic

Many condenser types are supported by the Magnum controller including individual condensers per circuit, shared condensers between multiple circuits, and common condensers for all circuits. The type of condenser plus the number of Relay Outputs needed are specified in MCS-Config.

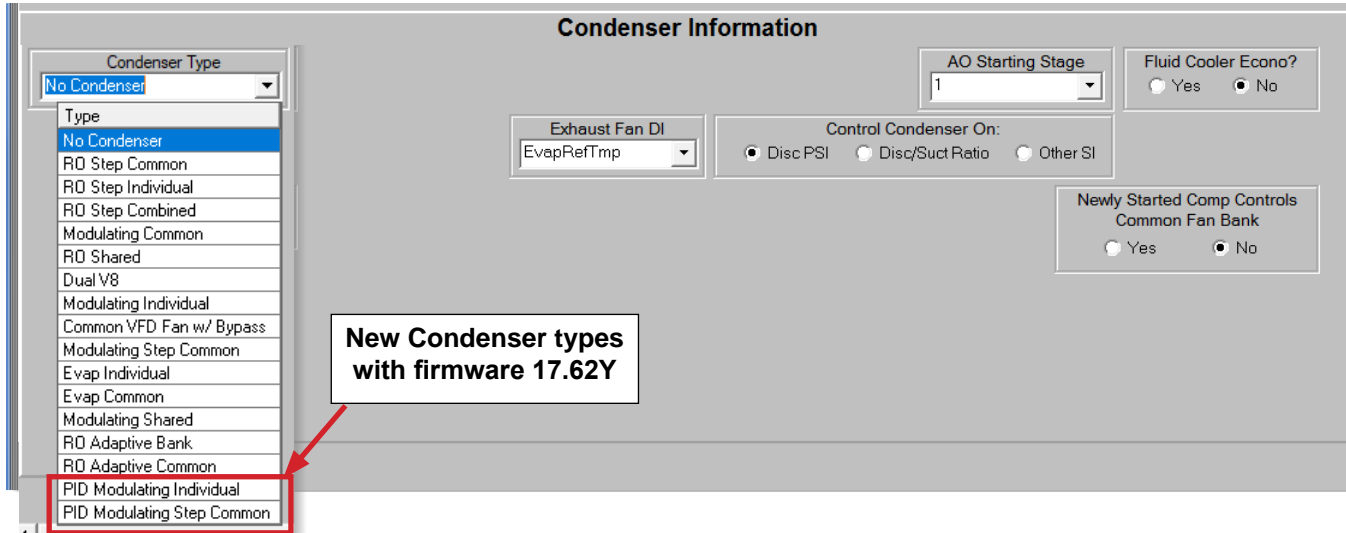

The Magnum supports the following Condenser Types:

- **No Condenser**
No condenser specified.
- **RO Step Common**
The highest discharge pressure from any compressor on the system will be the controlling pressure.
- **RO Step Individual**
Each compressor will have one or more condenser Relay Outputs associated with it. The discharge pressure on that compressor will be the control pressure for its own condenser.
- **RO Step Combined**
The highest discharge pressure from either of the compressors on the shared circuits will be the controlling pressure (circuits 1 and 2 are shared, circuits 3 and 4 are shared, circuits 5 and 6 are shared, and circuits 7 and 8 are shared).
- **Modulating Common**
The highest discharge pressure from any compressor on the system will be the controlling pressure. The Analog Output is modulated based on the Rate of Change of the controlling discharge pressure. It can also be controlled on a selected sensor input.
- **Modulating Step Common**
This type of condenser has a common fan bank for the system. The control will be on the systems highest discharge pressure. The Relay Outputs are also supported along with an Analog Output.
- **Modulating Individual**
Each compressor will have its own condenser Analog Outputs associated with it. The Analog Output for each circuit is modulated based on its own discharge pressure Rate of Change. It can also be controlled on a selected sensor input. You may also select Relay Outputs to be turned ON/OFF while modulating the Analog Output.

■ **RO Shared**

This type of condenser will take the highest discharge pressure of circuits 1 and 2, then 2 and 3, then 3 and 4, etc. to use as the control discharge pressure. This condenser type does not have the option to bypass the startup compressor.

■ **Dual V8**

This special type of condenser is a common control air condenser with two stages of fans plus a VFD Fan. Control of the fan speed will be different depending on whether one or two stages are on. All compressors are in the same fan bank with the highest discharge pressure being the control.

■ **Common VFD Fan with Bypass**

Three consecutive Relay Outputs, an Analog Output, and a VFD fault indicator are required to control this type of condenser. RO's needed:

- 1) VFD LOAD—This relay will be ON indicating the fan can be used.
- 2) VFD BYPS—This relay will be OFF unless a VFD fault has occurred.
- 3) VFD ENAB—This relay will be ON unless a VFD fault has occurred.

During normal operation, VFD LOAD will be on, VFD BYPS will be off, and VFD ENAB will be on. The fan will be modulated as required by the condenser or economizer logic. If a fault occurs, all relays will be turned off and the VFD will be set to 0. The Magnum will wait for the time specified in Setpoint #90 "COND FAULT" before the fan will be run without VFD control if it is needed by the condenser logic (economizer logic will not function in this condition). Once this time has passed and the condenser logic calls for the fan, then VFD BYPS will be turned on thereby turning the fan on, however it will NOT be modulated.

The Magnum can also support a variable speed fan for all three of the air type of condensers. Each compressor can support a variable speed fan. The variable speed must be on the first Relay Output associated with that compressor.

Note 1: The discharge temperature must be at least 117° F and the discharge superheat needs to be at least 20° F to guarantee good oil separation.

Note 2: Condenser staging is critical if the Magnum is to function in different climates. The best option for air-cooled chillers is to have each fan on its own contactor and a frequency drive on fan 1. This configuration allows the most optimum control in all weather.

■ **Modulating Step Common**

Similar to the Modulating Common type with the addition of relay outputs. The highest discharge pressure from any compressor on the system will be the controlling pressure. The Analog Output is modulated based on the Rate of Change of the controlling discharge pressure. It can also be controlled on a selected sensor input. When the analog output reaches its maximum value and more cooling is required the next relay will be turned on and the analog output value will be set to its minimum value.

■ **Evap Individual**

Evaporative condensers are used to improve the condensers efficiency by spraying water over the condensing coil from above while air is blown up through the coil from below. Each compressor will have its own condenser Analog Outputs associated with it. The Analog Output for each circuit is modulated based on its own discharge pressure Rate of Change. It can also be controlled on a selected sensor input. You may also select Relay Outputs to be turned ON/OFF while modulating the Analog Output.

■ **Evap Common**

Evaporative condensers are used to improve the condensers efficiency by spraying water over the condensing coil from above while air is blown up through the coil from below. Similar to the Modulating Common type with the addition of relay outputs. The highest discharge pressure from any compressor on the system will be the controlling pressure. The Analog Output is modulated based on the Rate of Change of the controlling discharge pressure. It can also be controlled on a selected sensor input. When the analog output reaches its maximum value and more cooling is required the next relay will be turned on and the analog output value will be set to its minimum value.

- **RO Adaptive Bank– Air cooled Condenser Fan Control**
 Used to control the condenser fan relay outputs for a single compressor, multiple compressors on the same refrigerant circuit, or a bank of condenser fans for multiple refrigerant circuits. If single compressor the condenser fans are stage on/off based on the compressor discharge pressure. If multiple compressor or refrigerant circuit, then the high discharge of the running compressors is used to stage condenser fans.
- **RO Adaptive Common – Air Cooled Condenser Fan Control**
 Used to control the condenser fan relay outputs for all the refrigerant circuits on the unit. This control logic finds the high discharge pressure on the running compressors and uses it to stage on/off the condenser fan relays.
- **PID MOD Individual**
 Required software:
 Config version 18.01V or later
 Connect version 18.31 or later
 Firmware 17.62Y (all firmware except LWC MAG and CPM MAG)
 Each compressor will have its own condenser Analog Outputs associated with it.
 PID control will turn an analog output into a stand alone PID controlled output. This output will have a controlling sensor that modulates the AO to a maintain target. This logic will run all the time.
- **PID Step Common**
 Required software:
 Config version 18.01V or later
 Connect version 18.31 or later
 Firmware 17.62Y (all firmware except LWC MAG and CPM MAG)
 This type of condenser has a common fan bank for the system. The control will be on the systems highest discharge pressure.
 PID control will turn an analog output into a stand alone PID controlled output. This output will have a controlling sensor that modulates the AO to a maintain target. This logic will run all the time.

20.1. Condenser Introduction

20.1.1 RO Step Condenser Cut In – Out Logic

The Cut In and Cut Out Logic setpoints are as follows:

Setpoint #40 “CND STG1 ON” - Condenser stage 1 Cut In (ON).
 Setpoint #41 “CND STG1 OFF” - Condenser stage 1 Cut Out (OFF).
 Setpoint #42 “CND DIFF ON”- Cut In differential for additional condenser stages for (ON).

Setpoint #43 “CND DIFF OFF” - Cut Out differential for additional condenser stages (OFF). Setpoint #44 “CND MIN RUN” - Minimum run time for a condenser stage

Condenser Relay Outputs will be turned on based upon the value in setpoint #40 “CND STG1 ON”. When discharge pressure reaches this value, the first condenser Relay Output is turned on. If additional condenser outputs are present, they will be turned on when the pressure exceeds the cut in value plus the value contained in setpoint #42 “CND DIFF ON”. When discharge pressure falls, the condenser outputs will be turned off based upon the setpoint #41 “CND STG1 OFF” plus the value contained in setpoint #43 “CND DIFF OFF”. The first step will be turned off when discharge pressure falls below setpoint #41 “CND STG1 OFF”.

Example:

Setpoint #40 “CND STG1 ON”	= 200 psi
Setpoint #41 “CND STG1 OFF”	= 170 psi
Setpoint #42 “CND DIFF ON”	= 20 psi
Setpoint #43 “CND DIFF OFF”	= 5 psi

COND FAN 1 ON at 200 psi (Discharge)
 COND FAN 1 OFF at 170 psi
 COND FAN 2 ON at 220 psi (200 + 20)
 COND FAN 2 OFF at 175 psi (175 + 5)

COND FAN 3 ON at 240 psi (220 + 20)
 COND FAN 3 OFF at 180 psi (175 + 5)

20.1.2 RO Step Condenser with Variable Speed Fan

The Setpoints for variable speed fan control are as follows:

Setpoint #54 “CND MIN SPD” - Minimum variable speed allowed.

Setpoint #55 “CND MAX SPD” - Maximum variable speed allowed.

The purpose of the variable speed fan is to reduce the cycling of the fans by adjusting the speed of the variable fan point. This control works in conjunction with the Cut In and Cut Out logic of each compressor. When a fan is turned on, the speed of the variable point for that compressor is set to maximum allowed percentage. As the discharge pressure falls, the fan speed is adjusted proportionally. When the minimum is reached the fan will turn off.

20.1.2.1. Condenser Control

The Condenser Control logic is run with every pass of the algorithm.

20.1.2.2. Common Terms

Information that relates to condensers on the circuit								
# Cond Faults	Cond Fan Bank	Condenser Coil Temp #1	Condenser Coil Temp #2	Tandem EXV Circuit #	EXV Control	Suction Group	Comp Name/ID	
0	1	Not Used	Not Used	1	Suct Spht	1	1	
0	2	Not Used	Not Used	2	Suct Spht	2	2	
0	3	Not Used	Not Used	3	Suct Spht	3	3	

Condenser Fan Bank:

Indicates which circuits share common condenser fans or are individually controlled.

Suction Group:

Indicates which circuits share a common suction line.

Control Condenser On:

(Disc PSI)—The Magnum will check for the compressor with the highest discharge and use that as the controlling pressure.

20.1.2.3. Control Discharge Pressure Calculation

If control is based on discharge pressure, all types of condensers will operate in the following sequence. For compressors within the same fan bank or suction group, the compressor with the highest discharge pressure will be held as the control pressure, regardless if the compressors are running or not.

The newly started compressor will have the controlling discharge pressure even if it is not the highest value in order for it to build pressure (startup mode is defined as the compressor has been on for less than 5 minutes and its discharge pressure is less than the value of Setpoint #45 “CND STG1 ON” minus the value of Setpoint #47 “CND DIFF ON”). However, this logic will be overruled if another compressor sharing the same condenser approaches the high discharge safety (if discharge pressure rises above calculated value of Setpoint #81 “HI DISC PSI” minus #83 “HI DISC RELOAD”)

If control is based on Other SI, the value of that sensor is always used as the control discharge pressure.

Control Condenser On:

- **Disc PSI**—The Magnum will check for the compressor with the highest discharge and use that as the controlling pressure.
- **Disc/Suct Ratio** - Control logic will be the same as Disc PSI control except the ratio of the discharge pressure to the suction pressure will be used as the control. Note changes to related set points will be required.
- **Diff PSI(Disc-Suct)** -



HVAC FIRMWARE VERSION 17.34 and up
MCS-CONFIG VERSION 18.01G and up
MCS-CONNECT VERSION 18.20.06 and up
NEW LOGIC ADDED WITH THESE UPDATES

Control Condenser On:

Disc PSI

Disc/Suct Ratio

Diff PSI(Disc-Suct)

Other SI

Differential Condenser Target Adjustment

If Discharge Superheat <= for Seconds Then
 Increase Differential PSI Target By

If Discharge Superheat >= for Seconds Then
 Decrease Differential PSI Target By

Max Adjustment Allowed

This logic will utilize the calculated differential pressure (Discharge Pressure/Suction Pressure) to control the condenser.

System Status							
Capacity Control State	Time	Wanted/ Actual	Step Delay	Wanted %	Rate of Change	Control On	
UNIT IS LOADED	00:30:20	2/2	10	100.0	0.0	CHILWTROUT= 55.0F	
State	Time	PSI Diff	FLA %	Steps	Lead?	Manual FLA %	Condenser Adjustment
1)CMP IS HOLDING	00:19:25	265.0P	100%	1	Yes	N/A	40.0P
2)CMP IS HOLDING	00:19:20	200.0P	100%	1		N/A	0.0P
Suction Temp	Saturated Suction	Suction Superheat	Disc Temp	Saturated Discharge	Disc Superheat	Subcooling	
1) 58.0	31.5	26.5	120.0	110.0	10.0	20.0	
2) 58.0	42.9	15.1	130.0	101.6	28.4	11.6	

Differential Condenser Target A...

If Discharge Superheat <= for Seconds Then
 Increase Differential PSI Target By

If Discharge Superheat >= for Seconds Then
 Decrease Differential PSI Target By

Max Adjustment Allowed

CLEAR VALUE

1	2	3
4	5	6
7	8	9
-	0	.

ADJUST CANCEL

All condenser setpoints will remain the same for both modulating and step control. When Diff PSI is selected the below information will become editable in the config program.

Here you will be able to customize adjustments to the differential target based on discharge superheat being low or high.

In this config example if discharge superheat falls below 20 degrees for 30 seconds then the differential target will be increased by 5 psi. If 30 more seconds goes by and the discharge superheat has not increased above 20 degrees then we will do another increase of 5 psi to the target. The adjustments will continue all the way up to a maximum of 40 psi defined by our “Max Adjustment Allowed” box. Once discharge superheat is between the high and low settings the adjustment will hold where it’s currently at.

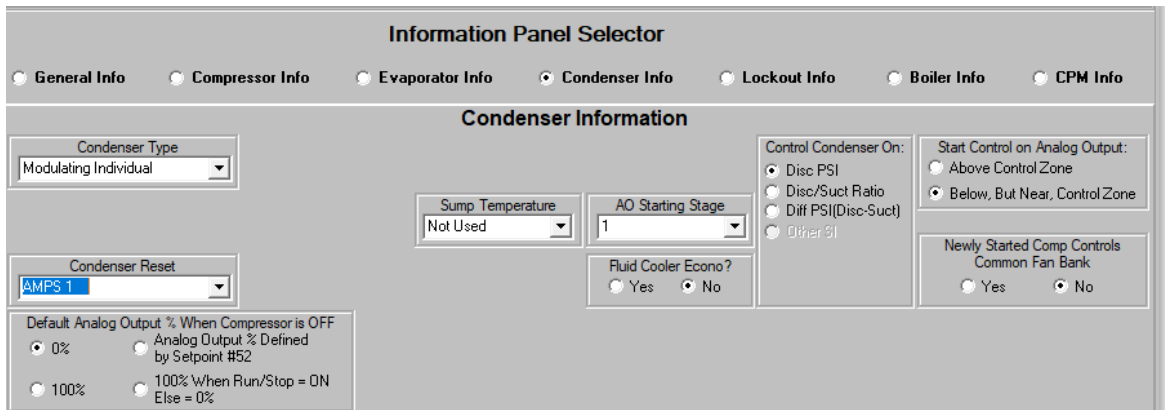

The logic works the same exact way when the discharge superheat rises above 40 degrees only we will decrease the differential every 30 seconds by 5 psi all the way back down to a 0 psi adjustment. The adjustments cannot go to a negative value.

MCS-CONNECT SCREEN ADJUSTMENT - Diff PSI(Disc-Suct

- **Other SI** - Control logic will be the same as Disc PSI control except the value of the sensor that is specified will be used as the control. Note changes to related set points will be required. When this option is selected a “Other Control Sensor” window will enable the sensor to be selected.



To use ‘Other SI’, the condenser type must be a ‘COMMON TYPE’

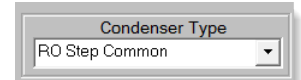

The Magnum will not check for the compressor with the highest discharge pressure but will always use the value of the sensor that is selected as the control.

20.1.2.4. Condenser Reset

If Diff PSI(Disc-Suct) is selected as your condenser type in the MCS Config program you’ll have a “Condenser Adjustment” box in your system status window through MCS Connect. Here you will see the adjustments made to your condenser target based on the discharge superheat. If you’re at least “Factory” authorized you can double click the value in the condenser adjustment box, it will open a window as you see in the example which will allow you to make changes to how the adjustments are made.

If sensor is specified its value will be added to the condenser control set points #45, #46 and #50.

20.1.2.5. Condenser Low Ambient

When a compressor is started its discharge pressure will be used as the controlling pressure for five minutes, enabling that compressor to build head pressure. However, if Setpoint #204 COND LOW AMB is active and there is an ambient temperature sensor reading less than this Setpoint, then this compressor’s discharge pressure will remain in control for an additional time as specified in the “Time (sec)” field.

20.1.2.6. Condenser Related Setpoints

The following are Condenser related Setpoints:

40	CND STG1 ON (Air cooled)	When the discharge pressure is above this value, turn on the first stage of the condenser fans. 'Time (sec)' field: (Applies to compressors with shared condensers) If non-zero, then the compressor in startup state will not be in sole control of the condenser fans, it will control off of highest discharge pressure. If zero, then compressor in startup will have sole condenser control for 5 minutes. This option is selected in in the 'Newly started Comp Controls Common Fan Bank' box in the 'Condenser Information' section under the MAG V8 tab.
41	CND STG1 OFF (RO Type)	If stage 1 of condenser capacity is on and the discharge pressure drops below this value, then turn this stage off.
42	CND DIFF ON (RO Type)	Differential pressure added to setpoint #45 to set the threshold at which each additional stage of condenser capacity will turn on.
43	CND DIFF OFF (RO Type)	Differential pressure added to setpoint #46 to set the threshold at which each additional stage of condenser capacity will turn off.
	CND DELAY (Modulating Type)	If active, this is the time in seconds between adjustments to the water valve. If inactive, then 30 seconds will be used as the delay.
	DUAL PSI DELTA (Dual V8)	Minimum difference in pressure before the second stage of condenser capacity can be started.
44	CND MIN RUN (Modulating Type)	Once a condenser stage has been turned on, it will remain on for at least the amount of minutes specified in this setpoint.
	DUAL TIME DELAY (Dual V8)	Time delay once the pressure difference in setpoint #48 has been reached before the second condenser stage can be started.
	CND START % (Modulating Type)	If active, then the value is the starting % for the AO when the RO that is tied to it turns on. The value in the "Time (SEC)" cell is the AO starting stage. If no Relays are used when CMP starts set value.
45 **	NOT USED	
46	CND PSI TRGT	This is the value that the fans will be modulated to. The High and Low zone cells contain the respective values to form the deadband around the target.
47	CND ADJ DIV (Modulating Type)	Control scaling of the amount the AO is adjusted. The larger the number, the smaller the AO adjustment as the calculated adjustment will be divided by this value.
	CND VFD MIN	If there is a VFD associated with the condenser, this is the starting minimum speed. 'Time (sec)' field: This field contains the condenser stage that must be on before the VFD is modulated.
48	CND MIN SPD (Modulating Type)	Minimum AO % allowed. If compressor is off, then check the "Time (SEC)" field: If 0, then the AO % will be set to the value of this Setpoint. If 2 and the run/stop is set to run, then set the AO % to 100%, else set the AO % to 0%. This option is selected in the "Default Valve Opening % when Comp. is OFF" box in the condenser information section in the MAG HVAC screen.
49	CND ROC - (Modulating Type)	Maximum negative rate of change allowed. If the rate of change is less than this Setpoint, then stop modulating the AO. The absolute value of this Setpoint also serves as the maximum positive rate of change allowed. If the rate of change is greater than the absolute value of this Setpoint, then stop modulating the AO.
50	CND MIN SPD (Modulating Type)	Minimum speed percentage for variable speed condenser control.
	CND ADJ MULT (Modulating Type)	Controls scaling of the amount the AO is adjusted. The larger the number the larger the AO adjustment as the adjustment will be multiplied by this value.

51	CND MAX SPD (RO Type)	Maximum speed percentage for variable speed condenser control.
	CND MIN ADJ (Modulating Type)	The value in this Setpoint is the minimum % the AO will be modulated when a change is made.
52	COND LOW AMB	If active, standard condenser control on compressor startup logic will be bypassed when the ambient temperature is below this value. Normal condenser control will apply, where the compressor with the highest discharge pressure will control the condenser.
54	COND HI AMB	If active, standard condenser control on compressor startup logic will be bypassed when the ambient temperature is above this value. Normal condenser control will apply, where the compressor with the highest discharge pressure will control the condenser.
55	COND FAULT	If setpoint is active, and an alarm type, if a condenser fault occurs an alarm message will be generated. If an lockout type, and a condenser fault occurs, then all compressors associated with this fault will be locked off. For Common VFD Fan Condensers with Bypass: Time in seconds before the bypass can be used when a fault has occurred.
56	COND PHASE FAULT 1	If this set point is active and a digital input has been selected for the Condenser Phase Failure 1 when the compressor is on this digital input will be checked. If the digital input is on for the Time specified for this set point, the circuit will enter a safety state and an alarm will be generated indicating which circuit has the failure.
57	COND PHASE FAULT 2	If this set point is active and a digital input has been selected for the Condenser Phase Failure 2 when the compressor is on this digital input will be checked. If the digital input is on for the Time specified for this set point, the circuit will enter a safety state and an alarm will be generated indicating which circuit has the failure.

20.2. CONDENSER TYPES

20.2.1 No Condenser

This option indicates there is no condenser associated with this unit.

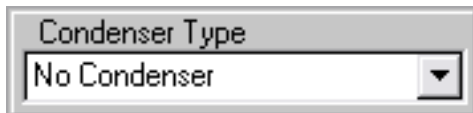

20.2.2 RO Step Common

Condenser Information

Condenser Type RO Step Common	Starting Cond RO Not Used	# of Cond Stages 0
Cond Starting Fault Not Used	# of Cond Faults 0	Fan AO Not Used
Condenser Reset Not Used	Newly Started Comp Controls Common Fan Bank <input type="radio"/> Yes <input checked="" type="radio"/> No	

The RO Step Common of condenser has one bank of fans. Make sure that all compressors in the Circuit Base point to the same common fan bank. The above example does not have a Fan Analog Output and there are three stages of fans starting with CND FAN 1 relay. All stages must be consecutive Relay Outputs.

For example:

Setpoint #	Name	Value
40	CND STG1 ON	200.0P

41	CND STG2 OFF	170.0P
42	CND DIFF ON	15.0P
48	CND DIFF OFF	5.0P

Discharge control pressure is 200.0 P, CND FAN 1, first condenser stage will be turned on.

If control pressure is equal to or greater than 215.0 P then the second stage will be turned on. $(200.0 + (15.0 * 1))$

If control pressure is equal to or greater than 230.0 P then the third stage will be turned on. $(200.0 + (15.0 * 2))$

Discharge control pressure is above 230.0 P; all three condenser stages are on.

When the control pressure drops below 180.0P the third condenser stage will be turned off. $(170.0 + (5.0 * 2))$

When the control pressure drops below 175.0P the second condenser stage will be turned off. $(170.0 + (5.0 * 1))$

When the control pressure drops below 170.0P the first condenser stage will be turned off. (170.0)

Condenser Faults

This example has no condenser faults. If used, and any one of the digital inputs are ON for the time specified in Setpoint #90 if active, then the unit will be locked out and an alarm message will be generated.

20.2.3 RO Step Common with a Fan AO and Condenser Faults



The above example is the same as the previous example with the addition of a Fan AO and two condenser faults.

Fan AO Control (same for all types of air condenser control)

Two more Setpoints than the previous example are needed to control the speed of the fan:

Setpoint #	Name	Value
50	CND MIN SPD	20.0%
51	CND MAX SPD	100.0%

CND FAN 1 will be turned on when the control pressure is equal to or greater than 200.0, same as in previous example. At this point the Fan AO speed will be set to its maximum value, Setpoint #55. If the pressure changes between 170.0 and 214.9 the fan speed will also be modulated proportionally between its maximum and minimum settings. If the pressure is at 185.0 the fan speed will be set to 61.2%. If the pressure is at 190.0 the fan speed will increase to 75.0%. This will provide precision control in maintaining optimum discharge pressure.

If the pressure increases to 215.0 the condenser’s second stage will be turned on and the fan speed will also be at 100.0%. If the pressure changes between 175.0 and 229.9 the fan speed will also be modulated proportionally between its maximum and minimum settings.

If the pressure increases to 230.0 the condenser’s third stage will be turned on and the fan speed will also be at 100.0%. If the pressure changes between 180.0 and 229.9 the fan speed will also be modulated proportionally between its maximum and minimum settings. If the pressure is at 230.0 and above the fan speed will be at 100.0%.

As the pressure decreases toward the Cut Out point the fan speed will decrease toward its minimum setting. Once a stage is turned off, the fan speed will be set to 100.0% and again it will be modulated based upon the pressure.

Condenser Faults

This example has two condenser faults. They must be consecutive digital input types starting with FAN FLT 1. If either of these digital inputs are ON for the time specified in Setpoint #90 if active, then the unit will be locked out and an alarm message will be generated.

20.2.4 RO Step Individual

Condenser Information

Condenser Type
RO Step Combined

Condenser Reset
Not Used

AO Starting Stage
1

Newly Started Comp Controls
Common Fan Bank
 Yes No

The RO Step Individual has a bank of fans for each compressor. The number and location of the fan are specified under the Circuit Base screen.

Information that relates to condensers on the circuit												
Circuit # (reset button)	# of Cond ROs	Starting Condensor RO	Condensor Fan AO	Starting Condenser Fault	# Cond Faults	Cond Fan Bank	Condenser Coil Temp #1	Condenser Coil Temp #2	Tandem EXV Circuit #	EXV Control	Suction Group	Comp Name/ID
1	3	CND FAN 1	Not Used	Not Used	0	1	Not Used	Not Used	1	Suct Splr	1	1
2	3	CND FAN 2	Not Used	Not Used	0	2	Not Used	Not Used	2	Suct Splr	2	2

of Cond ROs –Total number of Relay Outputs of each compressor, in this example there are 3. The number of fans in each compressor does not have to be the same.

Starting Condenser RO – The starting condenser Relay Output. All the Relay Outputs specified for each circuit must follow consecutively to this point. In this example CND FAN 1 is the starting Relay Output for circuit 1 and the other 2 fans follow consecutively in the RO screen.

Condenser Fan AO—If a condenser fan AO was specified in this cell it would function as described in the example in section 7.74.3.6 RO Step Common with a Fan AO and Condenser Faults. There is no condenser fan AO in this example.

Starting Condenser Fault—If there were condenser faults specified in this cell they would function as described in the example in section 7.74.3.6 RO Step Common with a Fan AO and Condenser Faults. There are no condenser faults in this example.

Cond Faults – Total number of Condenser Faults.

Cond Fan Bank – In this type of condenser all compressors should have a different fan bank.

Each compressor fan bank is controlled individually. The discharge pressure for each compressor is used to control condenser logic.

20.2.5 RO Step Combined

The RO Step Combined has a bank of fans that are shared by two consecutive circuits. The number and location of the fans are specified in the Circuit Base screen. This is similar to the RO Step Individual set up except only every other compressor has a condenser fans associated with it.

Information that relates to condensers on the circuit												
Circuit # (reset button)	# of Cond RDs	Starting Condenser RD	Condensor Fan AO	Starting Condenser Fault	# Cond Faults	Cond Fan Bank	Condenser Coil Temp #1	Condenser Coil Temp #2	Tandem EXV Circuit #	EXV Control	Suction Group	Comp Name/ID
1	...	3	FAN 1&3 #1	Not Used	Not Used	0	1	Not Used	Not Used	1	Suct Sptr	1
2	...	0	Not Used	Not Used	Not Used	0	1	Not Used	Not Used	2	Suct Sptr	2
3	...	3	FAN 2&4 #1	Not Used	Not Used	0	3	Not Used	Not Used	3	Suct Sptr	3
4	...	0	Not Used	Not Used	Not Used	0	3	Not Used	Not Used	4	Suct Sptr	4

Circuit 1 and 2 will share the same fan bank specified in the ‘Cond Fan Bank’ cell. Circuit 3 and 4 will also share the same fan bank specified. The highest discharge pressure between the two compressors on each respective circuit will be used as the control pressure for their fan bank.

Condenser Faults

If any of these digital inputs are ON for the time specified in Setpoint #90 if active, then both compressors sharing that condenser will be locked out and an alarm message will be generated. This example has no condenser faults.

20.2.6 Modulating

20.2.6.1. Modulating Common

This type of condenser uses water for condenser cooling. The AO Modulating Valve will modulate the cold water valve based upon the system's highest discharge pressure.

When the delay counts down to zero, an adjustment will be made based on the equation: (Control discharge pressure – Setpoint #50) × Setpoint #54 ÷ Setpoint #51 = Adjustment Value.

When the control discharge pressure is greater than Setpoint #50 plus the value in the high zone: If the control discharge pressure rate of change is dropping too fast (more than twice the value of Setpoint #53), then close the valve by the calculated adjustment. If the control discharge pressure rate of change is dropping too slowly (more than the value of Setpoint #53), then open the valve by the calculated adjustment. Else make no adjustment.

When the control discharge pressure is less than Setpoint #50 minus the value in the low zone: If the control discharge pressure rate of change is increasing too fast (more than twice the value of Setpoint #53) and the control discharge pressure is greater than Setpoint #50 minus 20.0 psi (1.3 bar), then close the valve by the calculated adjustment. If the control discharge pressure rate of change is increasing too slowly (more than the value of Setpoint #53), then open the valve by the calculated adjustment. Else make no adjustment.

When the control discharge pressure is within the zone: If the control discharge pressure rate of change is increasing more than the value of Setpoint #53, then close the valve by 1 percent. If the control discharge pressure change is decreasing more than the value of Setpoint #53, then open the valve by 1 percent.

Modulating Condenser Type: If heat pump and the mode is HEAT (not in defrost) all condenser relays will be turned on and the VFD set to 100% when compressor is turned on. If the control pressure is above the control zone, the condenser will unload; if below the control zone the condenser will load else there will be no change.

20.2.7 Modulating Step Common

Condenser Information

Condenser Type Modulating Step Common	Starting Cond RO CND1 ENBL	# of Cond Stages 2		
Cond Starting Fault Not Used	# of Cond Faults 0	Fan AO CND SPD% 1	Start Control on Analog Output: <input type="radio"/> Above Control Zone <input checked="" type="radio"/> Below, But Near, Control Zone	
Condenser Reset Not Used			Newly Started Comp Controls Common Fan Bank <input type="radio"/> Yes <input checked="" type="radio"/> No	
Default Analog Output % When Compressor is OFF <input checked="" type="radio"/> 0% <input type="radio"/> Analog Output % Defined by Setpoint #52 <input type="radio"/> 100% <input type="radio"/> 100% When Run/Stop = ON Else = 0%				

When a RO is being used with an AO the AO will key off the RO turning on. The RO will turn on when the discharge pressure enters the bottom of the CND HI/LO ZONE (Setpoint #193). At that time the AO will move to its starting % (Setpoint #49). The AO will stay at its starting % until the discharge pressure gets outside the top of the CND HI/LO ZONE (Setpoint #193). At that point the AO will modulate based on Setpoints #51, #53-55. Now if there are 2 RO's tied to the AO and the "AO Starting Stage" is 1 then once the AO gets to 100% the 2nd RO will be turned on after a delay (value in the "MIN VFD Opening" cell for Setpoint #48) and the AO will be set back to its minimum % (Setpoint #52) and then modulate as described above. Now if the pressure begins to fall and goes below the CND HI/LO ZONE (Setpoint #193) the AO will modulate. Once the AO gets to its minimum % (Setpoint #52) the 2nd RO will be turned off after a delay (value in the "MAX VFD Opening" cell for Setpoint #48) and the AO will be set back to 100% and continue to modulate as needed.

If the "AO Starting Stage" is 2 then when the discharge pressure enters the bottom of the CND HI/LO ZONE (Setpoint #193) the 1st RO (stage 1) will be turned on. The 2nd RO will turn on once the discharge pressure

gets outside the Heating Info CND HI/LO ZONE (Setpoint #193) and the delay has been met (value in the “MIN VFD Opening cell” for Setpoint #48) at that time AO will be set to its starting % (Setpoint #49). If the discharge falls below the CND HI/LO ZONE (Setpoint #193) the AO will begin to modulate. Once the AO reaches its minimum % (Setpoint #52) it will turn off the associated RO after a delay (value in the “MAX VFD Opening” cell for Setpoint #48). The 1st RO will remain on until the discharge pressure falls below the CND HI/LO ZONE (Setpoint #193) and the delay has been met (value in the “MAX VFD Opening” cell for Setpoint #48).

20.2.8 Modulating Individual

Condenser Information

Condenser Type: Modulating Individual

Fluid Cooler Econo?: Yes No

Sump Temp SI: Not Used

Control Condenser On: Disc PSI Other SI

Default Valve Opening % when Comp. is OFF: 0% Valve % defined by Setpoint #52 100% when Run/Stop = ON else = 0%

Newly started Comp Controls Common Fan Bank: Yes No

This type of condenser uses water to provide cooling to the compressors. The AO Modulating Valve will modulate the cold water based upon this discharge pressure for each circuit. You may also select Relay Outputs to be turned ON/OFF while modulating the Analog Output.

The individual condensers must be set up in the Circuit Base screen.

The control will be similar to the Modulating Common type, except that the discharge pressure for each circuit will control its own condenser.

20.2.9 RO Step Shared

Condenser Information

Condenser Type: RO Step Combined

Newly Started Comp Controls Common Fan Bank: Yes No

Condenser Reset: Not Used

AO Starting Stage: 1

The RO Shared condenser has banks of fans that are shared between two consecutive circuits. The number and location of the fans are specified under the Circuit Base screen. This is similar to the RO Step Individual set up.

Circuits 1 and 2 will share the fan bank that is specified in the circuit 1 grid in the Circuit Base screen. The highest discharge pressure of these two compressors will be used to control this bank of fans. Circuits 2 and 3 will share the fan bank that is specified in the circuit 2 grid in the Circuit Base screen. The highest discharge pressure of these two compressors will be used to control this bank of fans. In a unit with three circuits, circuit three will not have a fan bank associated with it. It shares circuit 2’s fan bank.

20.2.10 Dual V8

This is a special type of condenser. It is a common circuit control type with two stages of fans and VFD. The control of the fan speed will be different depending on whether one or two stages are on. All circuits are checked to calculate the control discharge pressure, and should be in the same fan bank.

If the control discharge pressure is less than Setpoint #45, then both condenser stages are off and the fan speed is zero.

If the control discharge pressure is greater than Setpoint #45 and less than Setpoint #46 stage 1 will be on. The fan speed will be equal the value of (Setpoint #55 minus Setpoint #54) divided by (Setpoint #46 minus Setpoint #45) and then multiplied by (control discharge pressure minus Setpoint #46) plus Setpoint #54.

If the control discharge pressure increases while in stage 1 above the value of Setpoint #46 plus Setpoint #48 for the time contain in Setpoint #49 stage 2 will be entered. Both relays will be on and the fan speed will be equal the value of (Setpoint #55 minus Setpoint #54) divided by Setpoint #46 and then multiplied by (control discharge pressure minus Setpoint #46) plus Setpoint #54.

If the speed of the condenser fan is less than Setpoint #54 it will be set to that value or if the speed of the condenser fan is greater than Setpoint #55 it will be set to that value.

20.2.11 Common VFD Fan w/Bypass

Condenser Information

Condenser Type Common VFD Fan w/ Bypass	Starting Cond RO CND FAN1-1	# of Cond Stages 1	Fan AO CND1 VFD%	AO Starting Stage 1	Fluid Cooler Econo? <input type="radio"/> Yes <input checked="" type="radio"/> No
Cond Starting Fault Cmp1VfdFit	# of Cond Fault 1	Sump Temperature Not Used	Control Condenser On: <input checked="" type="radio"/> Disc PSI <input type="radio"/> Disc/Suct Ratio <input type="radio"/> Other SI		
Condenser Reset Not Used	Newly Started Comp Controls Common Fan Bank <input checked="" type="radio"/> Yes <input type="radio"/> No				

The Common VFD Fan with a Bypass type of condenser has one fan. All circuits will use this fan; make sure that all circuits in the Circuit Base point to the same common fan bank. The above setup shows that there is one condenser stage. However this type requires the following three consecutive Relay Outputs to be set up. For example:

1-5	...	VFD LOAD
1-6	...	VFD BYPASS
1-7	...	VFD ENABLE

This type of condenser requires one condenser fault. If the fault occurs then the VFD will be bypassed and the fan will run at 100% if needed.

40	CND STG1 ON <i>(Air cooled)</i>	When the discharge pressure is above this value, turn on the first stage of the condenser fans. 'Time (sec)' field: (Applies to compressors with shared condensers) If non-zero, then the compressor in startup state will not be in sole control of the condenser fans, it will control off of highest discharge pressure. If zero, then compressor in startup will have sole condenser control for 5 minutes. This option is selected in in the 'Newly started Comp Controls Common Fan Bank' box in the 'Condenser Information' section under the MAG V8 tab.
41	CND STG1 OFF <i>(RO Type)</i>	If stage 1 of condenser capacity is on and the discharge pressure drops below this value, then turn this stage off.
42	CND DIFF ON <i>(RO Type)</i>	Differential pressure added to setpoint #45 to set the threshold at which each additional stage of condenser capacity will turn on.
43	CND MAX SPD (RO Type)	Maximum speed percentage for variable speed condenser control.
55	COND FAULT	If setpoint is active, and an alarm type, if a condenser fault occurs an alarm message will be generated. If an lockout type, and a condenser fault occurs, then all compressors associated with this fault will be locked off. For Common VFD Fan Condensers with Bypass: Time in seconds before the bypass can be used when a fault has occurred.

Fan control when there is no fault:

The highest discharge pressure of all the compressors is the control value.

The first relay, VFD LOAD, is on and the second relay, VFD BYPASS, is off.

When the control discharge pressure is greater than the value of Setpoint #45, then the third relay (VFD ENABLE) will be turned on and the VFD will be set to the value of Setpoint #55. If the control discharge pressure decreases the VFD will be modulated between Setpoints #54 and #55 based upon the control discharge pressure.

Assume Setpoint values:

40	CND STG1 ON	250 psi
41	CND STG1 OFF	170 psi
48	CND MIN SPD	20%
51	CND MAX SPD	100%

When the discharge control pressure is greater than 250 psi the relay VFD ENABLE will be on and the VFD on the fan will be set to 100%. If the discharge control pressure drops to 210, then the fan speed will be set to 60%. The discharge control pressure is half of its Cut In and Cut Out range ($250 - 170 = 80 / 2 = 40 = 170 + 20 = 210$) therefore, the VFD will be positioned to half of its range ($100 - 20 = 80 / 2 = 40 + 20 = 60$). The VFD will continue to be modulated in this matter until the discharge control pressure drops below 170. Then the VFD will be at 0% and relay VFD ENABLE will remain on. If the pressure goes above 170 the VFD will be modulated. For example if the discharge control pressure goes to 190.0 the VFD will be set to 50%.

Fan control when a fault occurs:

If a fault occurs, an alarm message will be generated, relay VFD LOAD will Lock off, relay VFD ENABLE will be off, the VFD speed will be set to 0% and the bypass, VFD BYPASS, will be enabled if needed after waiting for 30 seconds, Setpoint #90. Once the fan bypass is enabled and the discharge control pressure goes above 250 psi the bypass will be turned on enabling the fan to run at 100% and it will remain on regardless of the discharge control pressure.

If the fault resets itself, and is no longer on, the state of VFD LOAD will be set to AUTO, the VFD BYPASS relay will be turned off and VFD will be enabled to control the fan speed if it is needed.

54	CND MIN SPD	20%
55	CND MAX SPD	100%
90	COND FAULT	30s

When the discharge control pressure is greater than 250 psi the relay VFD ENABLE will be on and the VFD on the fan will be set to 100%. If the discharge control pressure drops to 210, then the fan speed will be set to 60%. The discharge control pressure is half of its Cut In and Cut Out range ($250 - 170 = 80 / 2 = 40 = 170 + 20 = 210$) therefore, the VFD will be positioned to half of its range ($100 - 20 = 80 / 2 = 40 + 20 = 60$). The VFD will continue to be modulated in this matter until the discharge control pressure drops below 170. Then the VFD will be at 0% and relay VFD ENABLE will remain on. If the pressure goes above 170 the VFD will be modulated. For example if the discharge control pressure goes to 190.0 the VFD will be set to 50%.

Fan control when a fault occurs:

If a fault occurs, an alarm message will be generated, relay VFD LOAD will Lock off, relay VFD ENABLE will be off, the VFD speed will be set to 0% and the bypass, VFD BYPASS, will be enabled if needed after waiting for 30 seconds, Setpoint #90. Once the fan bypass is enabled and the discharge control pressure goes above 250 psi the bypass will be turned on enabling the fan to run at 100% and it will remain on regardless of the discharge control pressure.

If the fault resets itself, and is no longer on, the state of VFD LOAD will be set to AUTO, the VFD BYPASS relay will be turned off and VFD will be enabled to control the fan speed if it is needed.

20.2.12 Evaporative types of Condenser Control

Evaporative condensers are used to improve the condensers efficiency by spraying water over the condensing coil from above while air is blown up through the coil from below.

Two types are support:

Condenser Information

Condenser Type
Evap Individual

AO Starting Stage
0

Fluid Cooler Econo?
 Yes No

Sump Temperature
Not Used

Control Condenser On:
 Disc PSI
 Disc/Suct Ratio
 Other SI

Condenser Reset
Not Used

Sump Level Indicator
Not Used

Sump Heater Relay
Not Used

Start Control on Analog Output:
 Above Control Zone
 Below, But Near, Control Zone

Newly Started Comp Controls
Common Fan Bank
 Yes No

Default Analog Output % When Compressor is OFF

0%
 Analog Output % Defined by Setpoint #52
 100%
 100% When Run/Stop = ON Else = 0%

- Evap Individual Step, has the same control logic as Modulating Individual.
- Evap Common, has the same control logic as Modulating Common.

In addition to the standard control logic, the evaporative spraying water requires addition input.

Sump Temperature, this sensor will provide the temperature of the sump, area where the spray water is held.

Sump Level Indicator, if set point #249 and a digital input is specified, if it is continually on for the time greater than the value of the safety time of set point #249 a Sump Low Level alarm will be generated and this condenser will locked off. If the digital goes to an off state and the condenser is locked off, its state will be changed to auto and the condenser will be available.

Sump Heater Relay, if this relay and sump temperature sensor is specified and set point #250 is active, this relay will be turned on and off based upon the values of set point #250.

20.2.12.1. Viewing on MCS-CONNECT and MCS-MAGNUM LCD KEYPAD

20.2.12.1.1. MCS-Connect Display

New columns in the compressor section are being added to the control status window where the adaptive offset values will be display.

System Status									
Capacity Control State	Time	Wanted/ Actual	Step Delay	Wanted %	Rate of Change	Control On	Mode	Ref Type	
UNIT IS HOLDING	00:04:12	0/0	180	0.0	0.0	ChilWtrOut= 46.0F	COOLING	R22	
State	Time	PSI Diff	FLA %	Steps	Lead?	Manual FLA %	Cond. Adap. Cut In Offset		
1)FAST UNLOADING	00:04:12	97.0P	78%	0	Yes	N/A	5.0P		
2)SAFETY TRIPPED	00:04:12	97.0P	78%	0		N/A	0.0P		
Suction Temp	Saturated Suction	Suction Superheat	Disc Temp	Saturated Discharge	Disc Superheat	Subcooling	Liquid Temp	Saturated Liquid Temp	
1) 45.0	33.7	136.3	152.0	101.3	50.7	-3.7	105.0F	101.3	
2) 50.0	33.7	136.3	152.0	101.3	50.7	-3.7	105.0F	101.3	

20.2.12.1.2. MCS-MAGNUM LCD KEYPAD

The adaptive Offset value can be viewed on the MCS-Magnum LCD/Keypad by selecting the “Status” option from the Menu screen. Once in the “Status” screens page down to the compressor 1st screen showing Compressor state, state timer, Suct, Disch, OPD, and Motor values. Then press the right arrow button one time to scroll over to view the AMPS. On the second line below the AMPS heading (not the first line below the heading which displays the comp amps) the Adaptive Offset value is displayed.



20.2.13 PID MOD Individual

Each compressor will have its own condenser Analog Outputs associated with it. The Analog Output for each circuit is modulated based on its own discharge pressure Rate of Change. It can also be controlled on a selected sensor input. You may also select Relay Outputs to be turned ON/OFF while modulating the Analog Output.

PID control will turn an analog output into a stand alone PID controlled output. This output will have a control-sensor that modulates the AO to a maintain target. This logic will run all the time.

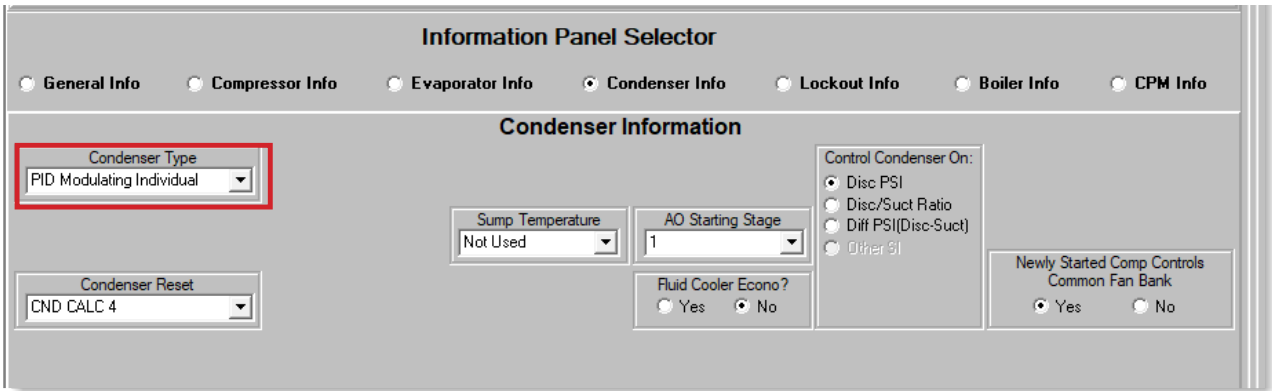

Setpoints used for PID Mod Individual and PID Step Common

40	CND STG1 ON (Air cooled)	When the discharge pressure is above this value, turn on the first stage of the condenser fans. 'Time (sec)' field: (Applies to compressors with shared condensers) If non-zero, then the compressor in startup state will not be in sole control of the condenser fans, it will control off of highest discharge pressure. If zero, then compressor in startup will have sole condenser control for 5 minutes. This option is selected in in the 'Newly started Comp Controls Common Fan Bank' box in the 'Condenser Information' section under the MAG V8 tab.
	PID MOD Individual PID Step Comm	If active, multiplier uses PID condenser control KP (Proportional). Setup as setpoint.
41	CND STG1 OFF (RO Type)	If stage 1 of condenser capacity is on and the discharge pressure drops below this value, then turn this stage off.
	PID MOD Individual PID Step Common	If active, uses Multiplier for Ki adjustments (Integral Time Delay). Setup as setpoint

42	CND DIFF ON (RO Type)	Differential pressure added to setpoint #45 to set the threshold at which each additional stage of condenser capacity will turn on.
	PID MOD Individual PID Step Common	If active, uses Multiplier for Kd adjustments, (ROC Time Delay). Setup as Target.
46	CND PSI TARG (Modulating Type)	Target discharge pressure which the condenser valve will try to maintain by modulating open or closed.
47	CND ADJ DIV (Modulating Type)	Controls scaling of the amount the valve is adjusted (Usually 1). The larger the number the smaller the valve adjustment as the adjustment will be divided by this value.
	CND VFD MIN	If there is a VFD associated with the condenser, this is the starting minimum speed. 'Time (sec)' field: This field contains the condenser stage that must be on before the VFD is modulated.
48	CND MIN SPD (Modulating Type)	Minimum valve opening percentage allowed. If the compressor is off, then check the 'Time (sec)' field: If 0, then set the VFD to the value of this setpoint. If 2 and the run/stop is set to run, then set the VFD to 100%, else set the VFD to 0%. This option is selected in in the 'Default Valve Opening % when Comp. is OFF' box in the 'Condenser Information' section under the MAG V8 tab.
49	CND ROC- (Modulating Type)	Maximum negative discharge pressure rate of change allowed. If the rate of change is less than this setpoint, then stop opening the valve. The absolute value of this setpoint also serves as the maximum positive rate of change allowed. If the rate of change is greater than the absolute value of this setpoint, then stop closing the valve.
50	CND MIN SPD (Modulating Type)	Minimum speed percentage for variable speed condenser control.
	CND ADJ MULT (Modulating Type)	Allows scaling of the amount the valve is adjusted. The larger the number the larger the valve adjustment will be multiplied by this value.
51	CND MAX SPD (Modulating Type)	Maximum speed percentage for variable speed condenser control.

Circuit Base settings

MAGNUM Circuit Base Screen												
Information that relates to Condensers and Evaporators on the circuit												
Circuit # (reset button)	# of Cond ROs	Starting Condenser RO	Condenser Fan AO	Starting Condenser Fault	# Cond Faults	Cond Fan Bank	Condenser Coil Temp #1	Condenser Coil Temp #2	Tandem EXV Circuit #	EXV #3 Circuit#	EXV #4 Circuit#	EXV #5 Circuit#
1	2	CND FAN1-1	CND1 VFD%	CND1 V FLT	1	1	CND1 COIL	Not Used	1	1	1	1
2	2	CND FAN2-1	CND2 VFD%	CND2 V FLT	1	2	CND2 COIL	Not Used	2	2	2	2

20.2.14 PID Step Common

This type of condenser has a common fan bank for the system. The control will be on the systems highest discharge pressure. The Relay Outputs are also supported along with an Analog Output.

PID control will turn an analog output into a stand alone PID controlled output. This output will have a controlling sensor that modulates the AO to a maintain target. This logic will run all the time.

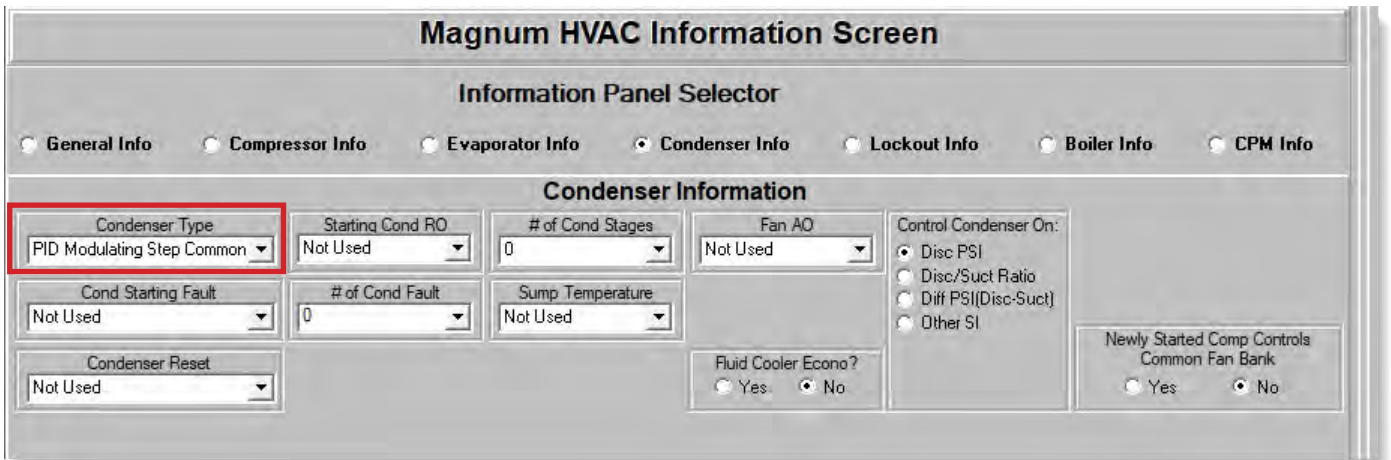

20.3. PID CONTROL

- **Control Target**
SI, AO, or Setpoint used as the target the AO will try to maintain.
- **AO**
Min to Max value the AO can modulate between.
- **Proportional(Kp)**
Multiplier for Kp adjustments.
- **Integral(Ki)**
Multiplier and delay between Ki Adjustments.
- **Derivative(Kd)**
Multiplier and time in seconds interval to calculate Kd.
- **Adjustment Limits**
Min and Max adjustments allowed to the AO per adjustment, both negative and positive.

Under the Analog Outputs window in the MCS Connect software. You'll find an AO PID tab that will show all of the PID CONTROL AOs and all of the calculated adjustments being made to those Analog Outputs. Here you will be able to see all three adjustments being made to the PID. This will assist you in any fine tuning required for the given analog output.

AO #	Analog Outputs	Value	Manual Status	Total Adj.	Proportional Adj.	Integral Delay	Integral Adj.	Derivative Adj.
M- 1	COMP1 SPD%	56.5%	AUTO	1773.2	138.94	0	131.25	138.74
M- 2	COMP2 SPD%	56.5%	AUTO	1798.6	172.03	0	166.97	123.36
M- 3	Exv#1-PID	42.3%	AUTO	1412.9	174.76	0	123.58	125.92
M- 4	Exv#2-PID	51.0%	AUTO	1387.4	177.17	0	172.01	138.94
1-1	CND1 VFD%	100.0%	AUTO	261.8	166.94	0	177.18	133.60
1-2	CND2 VFD%	99.6%	AUTO	1233.6	174.57	0	146.59	126.00
1-3	WTR PUMP1%	0.0%	AUTO	1670.6	174.62	0	128.54	141.49
1-4	WTR PUMP2%	100.0%	AUTO	1745.9	169.44	0	123.55	138.94
2-1	SCEXV1-PID	0.0%	AUTO	1746.4	125.93	0	123.56	169.51
2-2	SCEXV2-PID	0.0%	AUTO	1414.9	128.54	0	179.89	174.62

Chapter - 21. User Logic

Magnum provides the user the ability to customize control logic and calculated values. This is done in MCS-Config by defining a Sensor Input, Relay Output, or Analog Output as a User Logic type. This type of point can be adjusted through MCS-Connect by double clicking on the name of a User Logic point (This requires factory authorization) MCS-Connect identifies a user-defined Relay Output by following the name with (UL), a Sensor Input's Sensor Type cell has User Logic as the type and Analog Output's Type cell has Linear CTRL.

21.1. Operands

Operands are the building blocks of the Magnum User Logic. An operand consists of two parts: the top cell provides a drop down list to select the types and then a drop down list to select the item within that type:

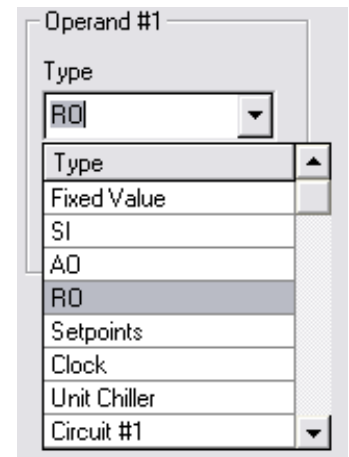

TYPE	ITEM
Fixed Value	Enter a fixed value with decimal place if required.
SI	Select Sensor Input
AO	Select Analog Output
RO	Select Relay Output
Setpoints	Select Setpoint, number is also display for ease of selection. All Setpoints are shown, both active and inactive.
CLOCK	Select system clock. The following can be selected: Hours, Minutes, Seconds, Day of Month, Day of Week (1 = Sunday–7 = Saturday), Year (2 digits), and Month (1-12). These are current values from the Magnum.
Unit Chiller	The following can be selected: FLA %, Steps wanted, Steps ON, Steps available, steps allowed on, % Load, STATE, Lead Compressor, Mode (cooling or heating), and Ice Mode Done (if ice mode option selected).
Compressor #1– Compressor #20	The following can be selected for any compressor: Compressor State, Suction Pressure, Discharge Pressure, Oil Pressure Differential, Motor Amps, Suction Temperature, Discharge Temperature, Oil Temperature, Motor Temperature, EXV Value Position, Oil Pressure, Refrigerant Temperature, Flow Indicator, Compressor Proof, Compressor Speed, Oil Float, Refrigerant Level, Condenser Temperature #1, Condenser Temperature #2, Fla %, Saturated Suction Temperature, Suction Superheat, Saturated Discharge Temperature, and Discharge Superheat. Note all of the above may not exist for an individual configuration.

The value that is passed to the User Logic depends on the item selected. For example:

- A Relay Output's value is 0 if it is off and a 1 if it is on.
- A Digital Input's value is 0 if it is off and a 1 if it is on.
- An Analog Input and Analog Output value are the actual values as displayed, includes the decimal place.
- The unit, compressor, or loop state is a numeric value that will relate to the state names in this manual. This value is show as the number in parenthesis following the state name.

21.2. Operators

The action cell is located between the operand cells.

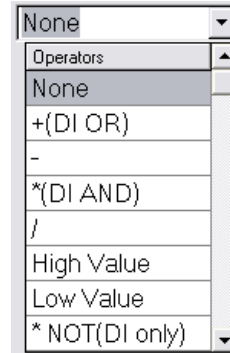

The following actions can be selected from a drop down list this will determine the value of the sensor:

Display as:	Action
None	Second operand is not required.
+ (DI OR)	Add the value of the two operands if they are analog values; if digital then they will be OR together. If digital and either operand is on the result will be 1 (ON).
-	Operand 1 minus Operand 2.
* (DI AND)	Operand 1 times Operand 2 if they are analog values; if digital then they will be AND together. If digital and both operands are on the result will be 1 (ON) else the result will be 0 (OFF).
/	Operand 1 divided by Operand 2
High Value	Result will be the highest value between Operand 1 and Operand 2
Low Value	Result will be the lowest value between Operand 1 and Operand 2
* NOT (DI only)	Operand 1 times the opposite value of Operand 2, which must be a digital. If Operand 2 is on value will be 1; therefore its opposite will be 0.
/ NOT (DI only)	Operand 1 divided by the opposite value of Operand 2, which must be a digital. If Operand 2 is on value will be 1; therefore its opposite will be 0.
>=	Sensor value will be on (true) if Operand 1 is greater than or equal to Operand 2.
<=	Sensor value will be on (true) if Operand 1 is less than or equal to Operand 2.
> NOT (DI only)	Sensor value will be on (true) if Operand 1 is greater than the opposite of Operand 2.
< NOT (DI only)	Sensor value will be on (true) if Operand 1 is less than the opposite of Operand 2.
==	Sensor value will be on (true) if Operand 1 is equal to Operand 2.
NOT = (DI only)	Sensor value will be on (true) if the opposite of Operand 1 is equal to Operand 2.

21.3. User Sensor Input

Selecting the “User Logic” display in the Sensor Information screen of MCS-Connect sets up this type of sensor. This type of sensor can be either an analog or digital sensor. This is a virtual input; the User Logic sensor value is a calculated value instead of a hardwired external sensor.

The screenshot shows a window titled "User Logic SI V11 Form" with the sensor name "LIQ TMP HI". The "Select Display Type (Do this FIRST)" dropdown is set to "TEMP". Under "LIQ TMP HI =", there are two operand boxes. "Operand #1" has a "Type" dropdown set to "SI" and a value dropdown set to "LIQ TMP 1". "Operand #2" has a "Type" dropdown set to "SI" and a value dropdown set to "LIQ TMP 2". A central dropdown menu is set to "High Value". At the bottom are "OK" and "Cancel" buttons.

First select the display type and then complete the selections. Note operand #1 and #2 are defined in the Operands section above and the Action Cell is defined in the drop down menu between.

The window below is from MCS-Config is configuring a User Logic type of sensor. It is a digit type of sensor (ON or OFF) and it is only looking an Operand 1. If the RO Sump and Doors is ON then the value of this sensor will be ON.

21.3.1 Examples of User Logic Sensor Inputs

The window below is from MCS-Config is configuring a User Logic type of sensor. If the Sump and Doors Relay Output is ON, then this sensor will read ON.

The screenshot shows a window titled "User Logic SI V11 Form" with the sensor name "Sump ON". The "Select Display Type (Do this FIRST)" dropdown is set to "DIGITAL/SW". Under "Sump ON =", there is one operand box. "Operand #1" has a "Type" dropdown set to "RO" and a value dropdown set to "Sump&Doors". A central dropdown menu is set to "None". At the bottom are "OK" and "Cancel" buttons.

The window below is from MCS-Config building a User Logic type of sensor. It is a pressure type of sensor (display a value with 1 decimal place). The value of this sensor will be result of Operand 1 minus Operand 2.

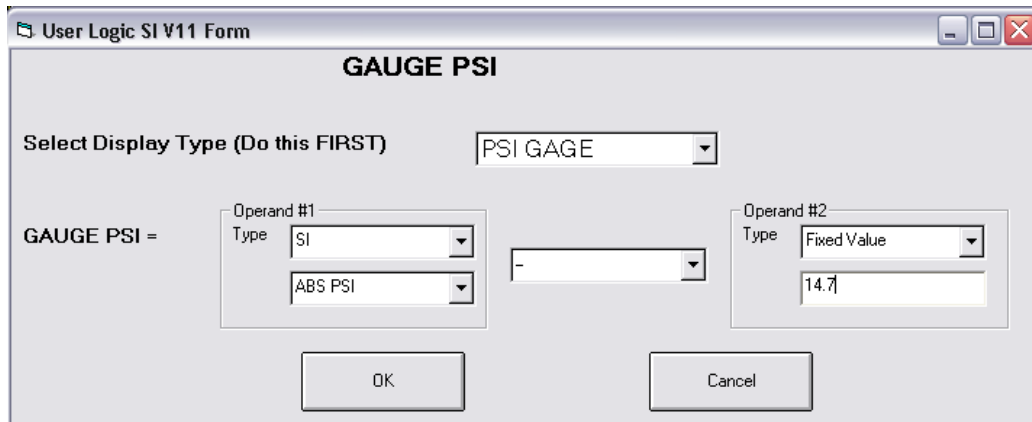

21.4. User Relay Output

User Relay Outputs allow customized control of relays based on operand values. The User Relay Output can calculate a value derived from two operands and combine the calculated value with a greater than and less than conditions to turn a relay ON/OFF. The User relay is capable of delaying the relay ON condition before turning the relay ON. Note this relay can be a virtual relay with nothing wired to it or an actual relay that controls an outbound device.

In the above example the “Store Alarm Msg” option has been enabled. When this relay goes from an OFF to an ON state an alarm message will be generated with the name of this relay.

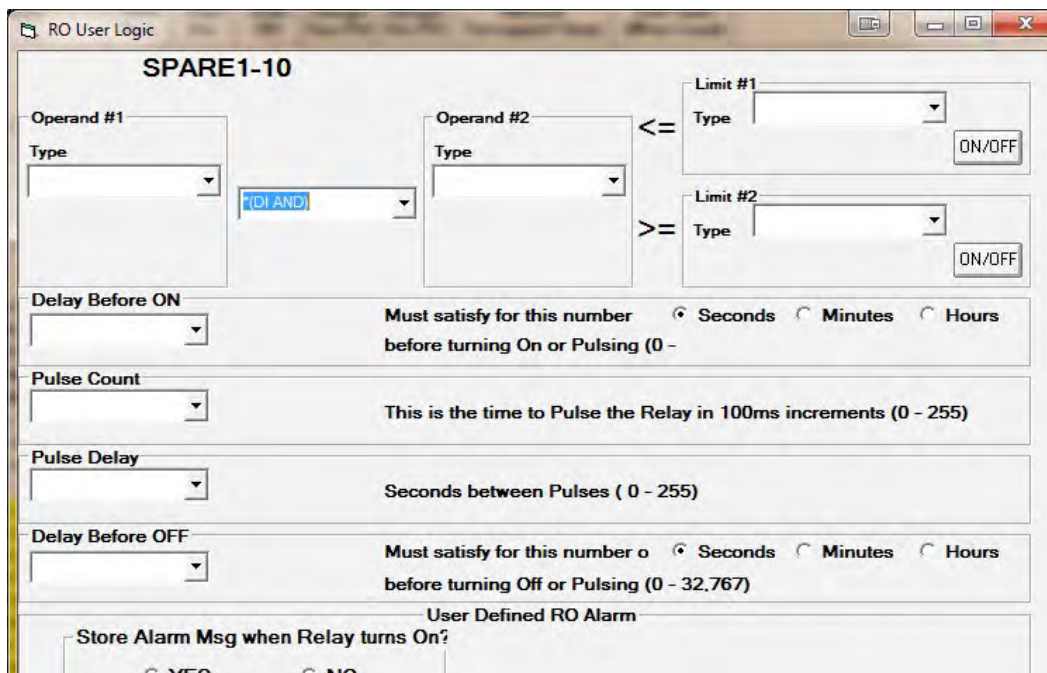

In this example, if either of the operands become true, then this relay will turn ON, an alarm message will be generated, and the General alarm relay will also turn ON.

21.5. User Analog Output

Linear control for Analog Output allows the user to control an analog value based on feedback from a Sensor Input or other operant control input value. The output can be set to control only when a relay is ON and fixed at a given output when the relay is OFF. Linear Control will monitor the Control Input and adjust the Analog Output based the minimum/maximum output values. Linear Control settings are adjustable through MCS-Connect with Factory level authorization.

In the above example if relay 'RUN' is OFF, the value of this Analog Output will be zero. If ON, the value will be calculated based on the Sensor Input 'ChilWtrOut'. If 'ChilWtrOut's value is 40 (or less) then the Analog Output will be set to 0%; If 60 (or above) then the Analog Output will be 100%. The output value will vary based on a linear calculation between these two points.

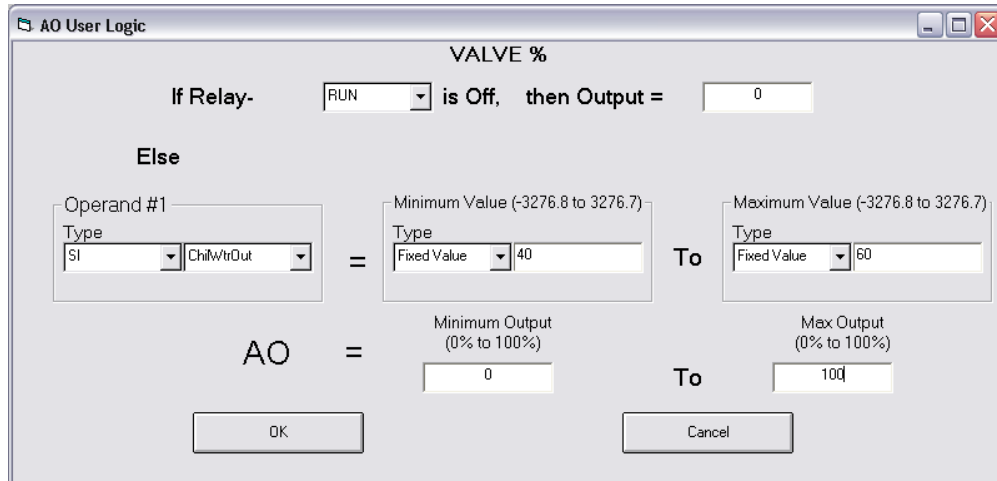

Chapter - 22. Electronic Expansion Valve Control Logic (EXV)

22.1. Electronic Expansion Valve Control Logic (EXV)

The function of the thermostatic expansion valve is to hold a constant evaporator superheat.

The EXV is set up in MCS-Config as follows:

Relay Output Information Screen											
Number	Name	Slide Mult.	Slide Div.	Slide Off.	Design Suc.PSI	Design Dis.PSI	Nominal Tonnage(of Step)	EXV Start (When Lead)	Type	EXV Load Adjust %	EXV Unld Adjust %
M-1	COMP 1						0	28.5	Step w\ EXV		

For relay outputs for Type of Step w\ EXV:

'EXV Start (when Lead)' cell contains the EXV start percentage if this relay is the lead compressor.

'EXV Load Adjust %' cell contains the percentage of adjustment to the EXV when a step is added.

'EXV Unld Adjust %' cell contains the percentage of adjustment to the EXV when a step is deleted.

By clicking on the 'Type of LLS' cell under the Circuit Base screen, select either EXV&LLS or EXV Only for EXV control.

By clicking on the 'EXV Output cell under the Circuit Base screen, select the analog output for controlling this circuits EXV.

By clicking on the 'EXV Control' cell under the Circuit Base screen, the option will cycle between Max Suction Superheat, Discharge Superheat, and Refrigerant Level control. By assigning the 2nd EXV for each circuit in the "Tandem EXV Circuit#" cell.

MAGNUM Circuit Base Screen

Information that relates to compressors on the circuit

Circuit# (reset button)	# of Comp R/Os	Starting Compressor R/O	Part Winding	Start Unload Bypass	Fast Unloader	Type of LLS	2nd LLS	Unloading Stages	Loader Type	HGB	HG Reheat	Liquid Injection	Oil Equalization	Low Disc SuperHeat	External Oil Pump Control	Number of EVAP/REHT	Max EVAP/REHT On	Ave There Reheat Relays?
1	4	COMP 1	No	No	No	EXV&LLS	Yes	0	Unload	None	No	No	No	No	No	0	0	No
2	4	COMP 2	No	No	No	EXV&LLS	Yes	0	Unload	None	No	No	No	No	No	0	0	No
3	0	Not Used	No	No	No	EXV only	No	0	Unload	None	No	No	No	No	No	0	0	No
4	0	Not Used	No	No	No	EXV only	No	0	Unload	None	No	No	No	No	No	0	0	No
5	0	Not Used	No	No	No	None	No	0	Unload	None	No	No	No	No	No	0	0	No
6	0	Not Used	No	No	No	None	No	0	Unload	None	No	No	No	No	No	0	0	No
7	0	Not Used	No	No	No	None	No	0	Unload	None	No	No	No	No	No	0	0	No
8	0	Not Used	No	No	No	None	No	0	Unload	None	No	No	No	No	No	0	0	No

Select Output and Sensor Inputs per circuit

Circuit # (reset button)	Comp Proof	Compr Speed(S) or Modulate Hot Gas All	Compressor Speed Fault	Slide Closed Indicator	Pump Down	Evaporator EXV Output	Circuit Pump/Valve
1	Not Used	CMP SPD%	Not Used	Not Used	DISABLE 1	EXV 1-1	Not Used
2	Not Used	CMP SPD%	Not Used	Not Used	DISABLE 2	EXV 2-1	Not Used
3	Not Used	Not Used	Not Used	Not Used	Not Used	EXV 1-2	Not Used
4	Not Used	Not Used	Not Used	Not Used	Not Used	EXV 2-2	Not Used
5	Not Used	Not Used	Not Used	Not Used	Not Used	Not Used	Not Used
6	Not Used	Not Used	Not Used	Not Used	Not Used	Not Used	Not Used
7	Not Used	Not Used	Not Used	Not Used	Not Used	Not Used	Not Used
8	Not Used	Not Used	Not Used	Not Used	Not Used	Not Used	Not Used

Information that relates to Condensers and Evaporators on the circuit

Circuit # (reset button)	# of Cond R/Os	Starting Condenser R/O	Condenser Fan AD	Starting Condenser Fault	# Cond Faults	Cond Fan Bank	Condenser Coil Temp #1	Condenser Coil Temp #2	Tandem EXV Circuit #	EXV #3 Circuit#	EXV #4 Circuit#	EXV #5 Circuit#	EXV #6 Circuit#	Evaporator EXV Control	Evaporator Type	Suction Group	Comp Name/ID
1	0	Not Used	CND SPD%	Not Used	0	1	Not Used	Not Used	3	1	1	1	1	Fast SSH II	DX Barrel	1	1
2	0	Not Used	CND SPD%	Not Used	0	2	Not Used	Not Used	4	2	2	2	2	Fast SSH II	DX Barrel	2	2
3	0	Not Used	Not Used	Not Used	0	1	Not Used	Not Used	3	3	3	3	3	Fast SSH II	DX Barrel	3	3
4	0	Not Used	Not Used	Not Used	0	2	Not Used	Not Used	4	4	4	4	4	Fast SSH II	DX Barrel	4	4
5	0	Not Used	Not Used	Not Used	0	5	Not Used	Not Used	5	5	5	5	5	Fast SSH II	DX Barrel	5	5
6	0	Not Used	Not Used	Not Used	0	6	Not Used	Not Used	6	6	6	6	6	Fast SSH II	DX Barrel	6	6
7	0	Not Used	Not Used	Not Used	0	7	Not Used	Not Used	7	7	7	7	7	Fast SSH II	DX Barrel	7	7
8	0	Not Used	Not Used	Not Used	0	8	Not Used	Not Used	8	8	8	8	8	Fast SSH II	DX Barrel	8	8

22.1.1 EXV Control States

The EXV Control States show the status of the compressor's expansion valve. If the compressor has an EXV it will be displayed under the Status entry.

Capacity Control State	Time	Wanted/ Actual	Step Delay	Wanted %	Rate of Change	Control On	Mode
UNIT IS HOLDING	00:00:16	1/1	60	100.0	0.0	ChilWtrOut= 55.0F	COOLING
State	Time	Oil Diff	FLA %	Steps	Lead?		
1)FAST UNLOADING	00:00:14	140.0P	97	1	Yes		
2)SAFETY TRIPPED	00:01:15	156.0P	116	0			
Suction Temp	Saturated Suction	Suction Superheat	Disc Temp	Saturated Discharge	Disc Superheat	Ref Type	
1) 45.0	33.0	12.0	152.0	100.6	51.4	R22	
2) 50.0	38.1	11.9	185.0	102.9	82.1	R22	
Valve State	Time	Valve %	SuperHeat	SuperHeat ROC	ADJ Delay		
1) EXV PRE-PMPDWN	00:00:16	15.0	12.0	0.0	0		
2) EXV IS CLOSED	00:01:16	0.0	11.9	0.0	0		

To view the EXV status through the Keypad LCD, select Status from the Main Menu and then page to the EXV screen.

EXV States:

LOCKED OUT	The compressor is in a Lockout state.
IS CLOSED	The associated compressor is OFF and the valve is closed
PRE-PMPDWN	The valve has been in a closed state and the system is now requiring the valve action.
IN STARTUP	At startup the valve will remain in this state for the time in Setpoint #20. At that time the state will be changed to holding, at this point the valve control logic will position the valve.
AT 100%	This state will be entered when the valve opening reaches 100%.
IS HOLDING	Refer to EXV Logic Chart, superheat is in control zone and ROC is acceptable.
IS OPENING	Refer to EXV Logic Chart, superheat is in control zone but rising too fast, ROC less than 1.0.
IS CLOSING	Refer to EXV Logic Chart, superheat is in the control zone and the rate of change is acceptable, ROC greater than -0.5.
LOW SPRHT	Refer to EXV Logic Chart, force a course valve adjustment.
OPENING 4x	Refer to EXV Logic Chart, superheat is above control zone.
OPENING 2x	Refer to EXV Logic Chart, superheat is in control zone but rising too fast, the ROC is greater than 1.0.
LO PSI OPN	Refer to EXV Logic Chart, state indicates that a low suction pressure condition exists. The suction pressure is less than Setpoint #77 "LOW SUCTION" plus twice the value of Setpoint #79 "LOW SUCT RELOAD" and the superheat is greater than Setpoint #9 "SUPERHT TRGT" plus twice the value of Setpoint #10 "SPRHT ZONE+-".
CLOSING 2x	Refer to EXV Logic Chart, superheat is in the control zone and the rate of change is acceptable, the ROC is less than -0.5 and greater than -1.0.
CLOSING 4x	Refer to EXV Logic Chart, superheat is in control zone but falling too fast, ROC less than -1.0.
HI LVL CLS	This state indicates that a high refrigerant level. This state is entered if Setpoint #109 "HiRefLevel" is active and the superheat is greater than the value of this Setpoint.
IS MOP CLS	Refer to EXV Logic Chart. Maximum operating pressure option is active and it is forcing the EXV to close. In this state the EXV valve's opening will be reduced.
IS MOP HLD	Refer to EXV Logic Chart. Maximum operating pressure option is active and it is forcing the EXV to hold.

22.1.2 EXV Maximum Operating Pressure

Setpoint #199 “MOP TARG PSI” must be active if the suction pressure is to be checked for maximum operating pressure.

If the suction pressure is above the MOP control zone, then the EXV state will be changed to EXV IS MOP CLS. The EXV valve opening will be closed by the value in Setpoint #201 with each adjustment. The ‘Time(sec)’ field of Setpoint #201 will be the delay between making adjustments to the EXV valves. The EXV will remain in this state until the suction pressure drops below the top of the MOP control zone. At this point the state will be changed to EXV IS MOP HOLD.

In the Compressor SI screen the active compressors information is to be completed as normal, while only the Suction Pressure and Suction Temperature must be entered for the tandem EXV. The different suction temperature provides separate control for the tandem EXV.

22.1.3 EXV control methods for Step Loading Compressors

Percentage per Step: (Requires Magnum Software HVAC 8.03L and MCS-Config 8.00W or higher)

To control the EXV based on a percentage per step for fixed step compressors, insert the relative load and unload adjustment percentages in the respective fields in the Relay Output screen. The load and unload adjustments will increase or decrease respectively based on a percentage of the current EXV position (not a fixed value)

Here is an example of a Hanbell Screw compressor configured to load by fixed steps:

Relay Output Information Screen							
Number	Name	EXV Start (When Lead)	Type	EXV Load Adjust %	EXV Unld Adjust %	Comments	
M-1	COMP 1	25	Step w\ EXV	50	60		...
M-2	LLS 1	-----	Standard	-----	-----		...
M-3	HotGasByps	0	Step w\ EXV	50	60		...
M-4	UNLOAD 50%	0	Step w\ EXV	30	40		...
M-5	UNLOAD 75%	0	Step w\ EXV	20	30		...

These columns are used for the compressor when there are multiple compressors on a single suction circuit, however, values must be in these fields for this logic to be in effect.

The logic will work as follows: When the compressor starts the EXV will go to the value in the ‘EXV Start (when lead)’ column, in this example it is 25%. The EXV will then modulate normally according to the controlling superheat or refrigerant level, until the unit is ready to load another step of capacity. Assume the EXV has stayed at 35% when the second step of capacity is ready to engage (turning off the Hot Gas Bypass). The EXV adjustment will be 50% (the amount in the ‘EXV Load Adjust’ column of the current EXV position

$$\text{‘EXV Load Adjust’ column (50\%)} \times \text{current EXV position (35\%)} = \text{EXV adjustment (17.5\%)}$$

$$50\% \times 35\% = 17.5\%$$

$$\text{Current EXV position (35\%)} + \text{EXV adjustment (17.5\%)} = \text{New EXV position (42.5\%)}$$

$$35\% + 17.5\% = 42.5\%$$

Therefore the final EXV valve position would be 42.5%

This same calculation will be repeated every time a new stage of capacity is turned on. Conversely, when the unit is unloading, the EXV adjustment will be subtracted from the current EXV position for every step that turns off. Assume the EXV is at 40% and the compressor is at 100% and is ready to unload a step (turning on Unload 75% solenoid).

$$\text{‘EXV Unld Adjust’ column (30\%)} \times \text{current EXV position (40\%)} = \text{EXV adjustment (12\%)} \quad 30\% \times 40\% = 12\%$$

$$\text{Current EXV position (40\%)} - \text{EXV adjustment (12\%)} = \text{New EXV position (28\%)} \quad 40\% - 12\% = 28\%$$

Therefore the final EXV valve position would be 28%

The values given in the example are only start points. You will need to adjust the values for your system. The idea is to jump the EXV position so that the superheat would still be above the target slightly, and then the EXV control logic would then adjust the value to achieve the target superheat. We do not want to open the EXV valve too much when loading or close the valve too much when unloading so we do not cause low superheat or liquid flooding to the compressor.

Chapter - 23. EXV Control SSH, SSH2

MCS has released two new superheat control systems in addition to its existing EXV Superheat Control Systems.

23.1. Fast Suction Superheat (Fast SSH)

Released with firmware 17.26-B.hex with the following objectives:

- Reduce the number of set points required. (SP 65 through 72 were eliminated)
- Provide only one control zone.
- Anytime the superheat moves outside this zone to recovery within two minutes or less.

Provide option to dynamically calculate the EXV starting position

23.2. Fast Suction Superheat 2 (Fast SSH2)

Released with firmware 17.37D1.hex with the following objectives:

- Provide MCS Default set points for all EXV controls types.
- Improve on self learning EXV Valve starting position.
- Add an extended SH ROC to allow finer decisions and reduce valve movement.
- Add explicit states for Fast SSH and Fast SSH2.

23.3. Selecting Fast SSH or Fast SSH2 in MCS-Config

In Fast SSH & Fast SSH2 only Set Points 9 through 20 are used to control the EXV valve. Select Type of Control in Relay Output Information Screen. In the RO screen, from the drop down window in 'Type' you select either 'Step w \ EXV' or 'Screw w \ EXV'

Point Number	Name	Slide Mult.	Slide Div.	Slide Off.	Design Suc.PSI	Design Dis.PSI	Nominal Tonnage(of Step)	EXV Start (When Lead)	Type
M-1	COMP	---	---	---	---	---	0	38	Step w \ EXV
M-2	REV VALVE	---	---	---	---	---	---	---	Step w \ EXV
M-3	SUPPLY FAN	---	---	---	---	---	---	---	Screw w \ EXV
M-4	SPAREM-4	---	---	---	---	---	---	---	Screw NO EXV
M-5	INV RUN	---	---	---	---	---	---	---	Pulse Relay
M-6	INV RESET	---	---	---	---	---	---	---	Alm-Emerg Stop
M-7	GARAGE LT	---	---	---	---	---	---	---	Alm-Freeze Fault
									Alm-Hi Sump Temp

23.4. Circuit Base

In the Circuit Base screen you need to select the Analog Output for the EXV.

Circuit # (reset button)	Alarm Relay	Comp Proof	Compr Speed(%) or Modulate Hot Gas Afl	Compressor Speed Fault	Slide Closed Indicator	Pump Down	Evaporator EXV Output	Flow	Circuit Pump/Valve
1	Not Used	Not Used	Not Used	Not Used	Not Used	DISABLE 1	EXV1 %	Not Used	Not Used
2	Not Used	Not Used	Not Used	Not Used	Not Used	DISABLE 2	RO		Not Used
3	Not Used	Not Used	Not Used	Not Used	Not Used	Not Used	EXV1 %		Not Used
4	Not Used	Not Used	Not Used	Not Used	Not Used	Not Used	EXV2 %		Not Used
5	Not Used	Not Used	Not Used	Not Used	Not Used	Not Used	CHW PMP1%		Not Used
6	Not Used	Not Used	Not Used	Not Used	Not Used	Not Used	CHW PMP2%		Not Used
7	Not Used	Not Used	Not Used	Not Used	Not Used	Not Used	CND VFD1%		Not Used
8	Not Used	Not Used	Not Used	Not Used	Not Used	Not Used	CND VFD2%		Not Used
9	Not Used	Not Used	Not Used	Not Used	Not Used	Not Used	SPARE1-3		Not Used

Next in the Circuit Base screen you need to select 'Fast SSH' or 'Fast SSH2' from the Evaporator EXV Control section drop down menu.

Circuit # (reset button)	# of Cond ROs	Starting Condenser RO	Condenser Fan AO	Starting Condenser Fault	# Cond Faults	Cond Fan Bank	Condenser Coil Temp #1	Condenser Coil Temp #2	Tandem EXV Circuit #	Evaporator EXV Control	
1	...	1	COND FAN	COND CTRL	Not Used	0	1	CONDIN T	Not Used	1	Fast SSH2
2	...	0	Not Used	Not Used	Not Used	0	2	Not Used	Not Used	2	Cond Lvl
3	...	0	Not Used	Not Used	Not Used	0	3	Not Used	Not Used	3	Fast SSH
4	...	0	Not Used	Not Used	Not Used	0	4	Not Used	Not Used	4	Fast SSH2
5	...	0	Not Used	Not Used	Not Used	0	5	Not Used	Not Used	5	Evap Appr
6	...	0	Not Used	Not Used	Not Used	0	1	Not Used	Not Used	1	Fast Evap App
7	...	0	Not Used	Not Used	Not Used	0	2	Not Used	Not Used	2	Fast EypLvl
8	...	0	Not Used	Not Used	Not Used	0	3	Not Used	Not Used	3	Fast DSH

With the release of Fast SSH2 MCS has released a new MCS-Config to support the new functions. The new MCS-Config provides a new tab, 'EXV Control', where you define your system. This then allows MCS-Config to provide MCS Default Set Point Values for you. The figure below shows the Current 'Circuit Base' tab and the new 'EXV Control' tab.



If you enter data in the EXV portion of the Circuit Base tab or in the EXV Control tab it is carried through to the other tab.

23.4.1 Selecting the 'EXV Control' tab you are prompted with the following:

Based on your selections will dictate the set points for compressor control. The subcooler set points are only displayed if a subcooler id present.

23.4.2 Selection Options

Superheat Control based on ?

Superheat Control method type ?

Config Creation or reset to MCS Defaults

EXV Control Wizard

<p>Control Parameter</p> <p><input checked="" type="radio"/> Suction Superheat</p> <p><input type="radio"/> Discharge Superheat</p> <p><input type="radio"/> Evaporator Level</p> <p><input type="radio"/> Condenser Level</p> <p><input type="radio"/> Approach</p>	<p>Heat Exchanger Type</p> <p><input type="radio"/> DX Coil</p> <p><input checked="" type="radio"/> Plate HX</p> <p><input type="radio"/> DX Barrel</p> <p><input type="radio"/> Flooded Barrel</p>	<p>Control Method</p> <p><input type="radio"/> Normal (Original)</p> <p><input type="radio"/> Fast I</p> <p><input checked="" type="radio"/> Fast II</p>	<p>Target Modifier</p> <p><input type="checkbox"/> Low Discharge Superheat</p> <p><input type="checkbox"/> Oversized Condenser/High Ambient</p> <p><input type="checkbox"/> Maximum Operating Pressure(MOP)</p> <p><input type="checkbox"/> Minimum Differential Pressure(MDP)</p> <p><input type="checkbox"/> Target Reset</p> <p><input type="checkbox"/> Low Suction</p> <p><input type="checkbox"/> Low/High Level</p> <p><input type="checkbox"/> Level-->CAP</p>	<div style="border: 1px solid gray; padding: 5px; width: 100px; margin: 0 auto;">Set Values to Default</div>
---	--	---	--	--

Evaporator Type being controlled ?

Functions Effecting Superheat control. Some require set points to be active



NOTE: Once you have clicked on the boxes for your setup, be sure to click on 'Set Values to Default'.

System Setup ROs Sls AOs MAG HVAC Circuit Base Circuit SI Setpoints Auth Schedule BMS Points EXV Control Lookup Table

EXV Control Wizard

Control Parameter

- Suction Superheat
- Discharge Superheat
- Evaporator Level
- Condenser Level
- Approach

Heat Exchanger Type

- DX Coil
- Plate HX
- DX Barrel
- Flooded Barrel

Control Method

- Normal (Original)
- Fast I
- Fast II

Target Modifier

- Low Discharge Superheat
- Oversized Condenser/High Ambient
- Maximum Operating Pressure(MOP)
- Minimum Differential Pressure(MDP)
- Target Reset
- Low Suction
- Low/High Level
- Level-->CAP

Set Values to Default

#	Name	Value	Min	Max	Adjust Value	Time (SEC)	Max Time Allowed (SEC)	Lockout Delay (HRS)	Safety Down Time(MIN)	Active or Non-Active	Select Value: # decimals & print char	Level Of Auth. To Display	Type of Setpoint	Comments	SEC to Ignore Safety	Window to Ext. Safety Time(SEC)	Safety Time Extension (SEC)
9	SH TRG/SHAvg	12	8	18	0.1	1	1	0	0	Active	TEMP	View Only	Time
10	FAST ZONE	2	1.6	3	0.1	0	0	0	0	Active	TEMP	View Only	Time
11	LD/ADJ/REHEAT	0.2	0	1	0.1	0	10	0	0	Active	HUMD or %	View Only	Time
12	SH MPY/ESPRD	2	1	3	1	1	5	0	0	Active	DIGITAL/SW	View Only	Time
13	ROC MPY/LSUC	2	1	3	1	3	5	0	0	Active	DIGITAL/SW	View Only	Time
14	LMIT ADJUST	1	0.1	1.5	0.1	0	0	0	0	Active	DEC/NOCH	View Only	Time
15	V MIN/LS MPY	3	2	50	1	2	5	0	0	Active	HUMD or %	View Only	Time
16	V MAX/NOTUSED	100	60	100	1	0	0	0	0	Active	HUMD or %	View Only	Setpoint
17	LO SUPERHEAT	3.5	2	5	0.1	60	120	2	10	Active	TEMP	View Only	Alarm	...	0	300	120
18	LOW PSI DELY	5	1	30	1	30	60	0	0	Active	SECONDS	View Only	Time
19	EXV DLY/SJrd	1	1	30	1	0	0	0	0	Active	SECONDS	View Only	Time
20	EXV STRT TIME	126	30	144	1	0	12	0	0	Active	SECONDS	View Only	Time

Selection Option →

Compressor EXV Results →

This will set the values to the default for 'Control Parameter, Heat Exchanger Type and the Control Method. Make note that clicking in the 'Target Modifier' require that some set points must be active.

23.4.3 Compressor EXV Results

#	Name	Value	Min	Max	Adjust Value	Time (SEC)	Max Time Allowed (SEC)	Lockout Delay (HRS)	Safety Down Time(MIN)	Active or Non-Active	Select Value: # decimals & print char	Level Of Auth. To Display	Type of Setpoint	Comments	SEC to Ignore Safety	Window to Ext. Safety Time(SEC)	Safety Time Extension (SEC)
9	FAST SH TRGT	12	8	20	0.1	3	7	0	0	Active	TEMP	View Only	Time
10	FAST CTL ZN	1.6	1	3	0.1	0	0	0	0	Active	TEMP	View Only	Time
11	EXV LD/UNLD%	0.3	0	0.5	0.1	0	0	0	0	Active	HUMD or %	View Only	Time
12	SH MPY/LSPRD	2	1	3	1	0	0	0	0	Active	DIGITAL/SW	View Only	Time
13	ROC MPY/LSUC	2	1	3	1	3	5	0	0	Active	DIGITAL/SW	View Only	Time
14	LIMIT ADJUST	1	0.1	1.5	0.1	0	0	0	0	Active	DEC/NOCH	View Only	Time
15	V MIN LS MPY	3	2	25	1	2	5	0	0	Active	HUMD or %	View Only	Time
16	V MAX	100	50	100	1	0	1	0	0	Active	HUMD or %	View Only	Setpoint
17	LO SUPERHEAT	3.5	2	5	0.1	60	120	2	10	Active	TEMP	View Only	Alarm	...	0	300	120
18	LOW PSI DELY	5	1	30	1	30	60	0	0	Active	SECONDS	View Only	Time
19	EXV DELAY	1	1	30	1	0	0	0	0	Active	SECONDS	View Only	Time
20	EXV STRT TIME	126	1	270	9	10	10	0	0	Active	SECONDS	View Only	Time

- Control on 'Suction Superheat'
- Evaporator Type 'Plate HX'
- Control Method 'Fast SSH2'
- MCS Default 'Selected'
- Degrees F or C are automatic

With this release of MCS-Config MCS has developed Default Set Points for all EXV Types

23.4.4 MCS EXV Factory Default Set Point

23.4.4.1. Fast SSH2, Suction Superheat, Plate HX

EXV Control Setpoints																	
#	Name	Value	Min	Max	Adjust Value	Time (SEC)	Max Time Allowed (SEC)	Lockout Delay (HRS)	Safety Down Time(MIN)	Active or Non-Active	Select Value: # decimals & print char	Level Of Auth. To Display	Type of Setpoint	Comments	SEC to Ignore Safety	Window to Ext. Safety Time(SEC)	Safety Time Extension (SEC)
9	TARG/S STOP	12	8	20	0.1	2	7	0	0	Active	... TEMP	Factory L1	Time		...	-----	-----
10	FAST CTL ZN	2	1.6	3	0.1	0	0	0	0	Active	... TEMP	Factory L1	Time		...	-----	-----
11	EXV LD/UNLD%	0	0	0.5	0.1	0	10	0	0	Active	... HUMD or %	Factory L1	Time		...	-----	-----
12	SH MPL/%SPRD	1	1	3	1	5	10	0	0	Active	... DIGITAL/S%	Factory L1	Time		...	-----	-----
13	ROC MPY/LSUC	1	1	3	1	4	15	0	0	Active	... DIGITAL/S%	Factory L1	Time		...	-----	-----
14	LIMIT ADJUST	0.5	0.1	1.5	0.1	0	0	0	0	Active	... DECINCH	Factory L1	Time		...	-----	-----
15	VMIN/LSH MPY	3	2	25	1	2	15	0	0	Active	... HUMD or %	Factory L1	Time		...	-----	-----
16	VMAX	100	50	100	1	0	0	0	0	Active	... HUMD or %	Factory L1	Setpoint		...	-----	-----
17	LO SUPERHEAT	3	2	5	0.1	60	300	2	10	Active	... TEMP	Factory L1	Alarm	...	0	300	120
18	LSUC/LSH DLY	1	1	10	1	1	10	0	0	Active	... SECONDS	Factory L1	Time		...	-----	-----
19	E DLY/S CALC	1	1	30	1	0	10	0	0	Active	... SECONDS	Factory L1	Time		...	-----	-----
20	E STRT/C DLY	126	1	270	1	8	15	0	0	Active	... SECONDS	Factory L1	Time		...	-----	-----

23.4.4.2. Fast SSH2, Suction Superheat, DX Coil

EXV Control Setpoints																	
#	Name	Value	Min	Max	Adjust Value	Time (SEC)	Max Time Allowed (SEC)	Lockout Delay (HRS)	Safety Down Time(MIN)	Active or Non-Active	Select Value: # decimals & print char	Level Of Auth. To Display	Type of Setpoint	Comments	SEC to Ignore Safety	Window to Ext. Safety Time(SEC)	Safety Time Extension (SEC)
9	TARG/S STOP	10	8	18	0.1	4	7	0	0	Active	... TEMP	Factory L1	Time		...	-----	-----
10	FAST CTL ZN	2	1.6	3	0.1	0	0	0	0	Active	... TEMP	Factory L1	Time		...	-----	-----
11	EXV LD/UNLD%	0.2	0	3	0.1	0	0	0	0	Active	... HUMD or %	Factory L1	Time		...	-----	-----
12	SH MPL/%SPRD	1	1	3	1	0	5	0	0	Active	... DIGITAL/S%	Factory L1	Time		...	-----	-----
13	ROC MPY/LSUC	2	1	3	1	3	5	0	0	Active	... DIGITAL/S%	Factory L1	Time		...	-----	-----
14	LIMIT ADJUST	0.5	0.3	0.5	0.1	0	0	0	0	Active	... DECINCH	Factory L1	Time		...	-----	-----
15	VMIN/LSH MPY	3	2	50	1	3	5	0	0	Active	... HUMD or %	Factory L1	Time		...	-----	-----
16	VMAX	100	60	100	1	0	0	0	0	Active	... HUMD or %	Factory L1	Setpoint		...	-----	-----
17	LO SUPERHEAT	4	2	4	0.1	60	120	2	5	Active	... TEMP	Factory L1	Alarm	...	0	300	120
18	LSUC/LSH DLY	5	2	15	1	5	15	0	0	Active	... SECONDS	Factory L1	Time		...	-----	-----
19	E DLY/S CALC	20	1	60	1	8	12	0	0	Active	... SECONDS	Factory L1	Time		...	-----	-----
20	E STRT/C DLY	126	30	180	1	8	12	0	0	Active	... SECONDS	Factory L1	Time		...	-----	-----

23.4.4.3. Fast SSH, Suction Superheat, DX Barrel

EXV Control Setpoints																	
#	Name	Value	Min	Max	Adjust Value	Time (SEC)	Max Time Allowed (SEC)	Lockout Delay (HRS)	Safety Down Time(MIN)	Active or Non-Active	Select Value: # decimals & print char	Level Of Auth. To Display	Type of Setpoint	Comments	SEC to Ignore Safety	Window to Ext. Safety Time(SEC)	Safety Time Extension (SEC)
9	TARG/S STOP	12	8	20	0.1	2	5	0	0	Active	... TEMP	Factory L1	Time		...	-----	-----
10	FAST CTL ZN	2	1.6	3	0.1	1	1	0	0	Active	... TEMP	Factory L1	Time		...	-----	-----
11	EXV LD/UNLD%	0	0	0.5	0.1	0	10	0	0	Active	... HUMD or %	Factory L1	Time		...	-----	-----
12	SH MPL/%SPRD	1	1	3	1	5	10	0	0	Active	... DIGITAL/S%	Factory L1	Time		...	-----	-----
13	ROC MPY/LSUC	1	1	3	1	4	15	0	0	Active	... DIGITAL/S%	Factory L1	Time		...	-----	-----
14	LIMIT ADJUST	0.2	0.1	0.4	0.1	3	6	0	0	Active	... DECINCH	Factory L1	Time		...	-----	-----
15	VMIN/LSH MPY	3	2	25	1	2	15	0	0	Active	... HUMD or %	Factory L1	Time		...	-----	-----
16	VMAX	100	50	100	1	0	0	0	0	Active	... HUMD or %	Factory L1	Setpoint		...	-----	-----
17	LO SUPERHEAT	3	1	5	0.1	120	300	2	10	Active	... TEMP	Factory L1	Alarm	...	0	300	120
18	LSUC/LSH DLY	1	1	10	1	1	10	0	0	Active	... SECONDS	Factory L1	Time		...	-----	-----
19	E DLY/S CALC	1	1	30	1	10	10	0	0	Active	... SECONDS	Factory L1	Time		...	-----	-----
20	E STRT/C DLY	126	1	270	1	8	15	0	0	Active	... SECONDS	Factory L1	Time		...	-----	-----

(Samples of Fast SSH & Fast SSH2 most often used)

23.4.4.4. Fast SSH2, Discharge Superheat, DX Barrel

EXV Control Setpoints																	
#	Name	Value	Min	Max	Adjust Value	Time (SEC)	Max Time Allowed (SEC)	Lockout Delay (HRS)	Safety Down Time(MIN)	Active or Non-Active	Select Value: # decimals & print char	Level Of Auth. To Display	Type of Setpoint	Comments	SEC to Ignore Safety	Window to Ext. Safety Time(SEC)	Safety Time Extension (SEC)
9	DShTRG/ShAvg	30	22	40	0.1	1	1	0	0	Active	... TEMP	Factory L1	Time		...	-----	-----
10	FAST ZONE	2	1.6	3	0.1	0	0	0	0	Active	... TEMP	Factory L1	Time		...	-----	-----
11	LdAdj/REHEAT	0.2	0	3	0.1	0	10	0	0	Active	... HUMD or %	Factory L1	Time		...	-----	-----
12	ShMpy/%SPRED	2	1	3	1	0	5	0	0	Active	... DIGITAL/S%	Factory L1	Time		...	-----	-----
13	RcMpy/LSuMpy	2	1	3	1	3	5	0	0	Active	... DIGITAL/S%	Factory L1	Time		...	-----	-----
14	LmZn/LmbZn	0.5	0.3	0.5	0.1	0	0	0	0	Active	... DECINCH	Factory L1	Time		...	-----	-----
15	VMIN/LSHMpy	3	2	50	1	3	5	0	0	Active	... HUMD or %	Factory L1	Time		...	-----	-----
16	VMAX/NOTUSED	100	60	100	1	0	0	0	0	Active	... HUMD or %	Factory L1	Setpoint		...	-----	-----
17	LSHf/TmFlt	4	2	4	0.1	60	120	2	5	Active	... TEMP	Factory L1	Alarm	...	0	300	120
18	LsStm/AdjTm	5	2	15	1	5	15	0	0	Active	... SECONDS	Factory L1	Time		...	-----	-----
19	EXVDly/Spred	1	1	60	1	8	12	0	0	Active	... SECONDS	Factory L1	Time		...	-----	-----
20	EXVStm/CmpDy	126	30	135	1	8	12	0	0	Active	... SECONDS	Factory L1	Time		...	-----	-----

23.4.4.5. Fast SSH, Suction Superheat, DX Barrel

EXV Control Setpoints																	
#	Name	Value	Min	Max	Adjust Value	Time (SEC)	Max Time Allowed (SEC)	Lockout Delay (HRS)	Safety Down Time(MIN)	Active or Non-Active	Select Value: # decimals & print char	Level Of Auth. To Display	Type of Setpoint	Comments	SEC to Ignore Safety	Window to Ext. Safety Time(SEC)	Safety Time Extension (SEC)
9	TARG/S STOP	12	8	20	0.1	2	5	0	0	Active	... TEMP	Factory L1	Time	
10	FAST CTL ZN	2	1.6	3	0.1	1	1	0	0	Active	... TEMP	Factory L1	Time	
11	EXV LD/UNLD%	0	0	0.5	0.1	0	10	0	0	Active	... HUMD or %	Factory L1	Time	
12	SH MPL/SPRD	1	1	3	1	5	10	0	0	Active	... DIGITAL/SW	Factory L1	Time	
13	RDC MPY/LSUC	1	1	3	1	4	15	0	0	Active	... DIGITAL/SW	Factory L1	Time	
14	LIMIT ADJUST	0.2	0.1	0.4	0.1	3	6	0	0	Active	... DECINCH	Factory L1	Time	
15	VMIN/LSH MPY	3	2	25	1	2	15	0	0	Active	... HUMD or %	Factory L1	Time	
16	VMAX	100	50	100	1	0	0	0	0	Active	... HUMD or %	Factory L1	Setpoint	
17	LD SUPERHEAT	3	1	5	0.1	120	300	2	10	Active	... TEMP	Factory L1	Alarm		... 0	300	120
18	LSUC/LSH DLY	1	1	10	1	1	10	0	0	Active	... SECONDS	Factory L1	Time	
19	E DLY/S CALC	1	1	30	1	10	10	0	0	Active	... SECONDS	Factory L1	Time	
20	E STRT/C DLY	126	1	270	1	8	15	0	0	Active	... SECONDS	Factory L1	Time	

23.4.4.6. Suct Spht, Suction Superheat, DX Barrel

EXV Control Setpoints																	
#	Name	Value	Min	Max	Adjust Value	Time (SEC)	Max Time Allowed (SEC)	Lockout Delay (HRS)	Safety Down Time(MIN)	Active or Non-Active	Select Value: # decimals & print char	Level Of Auth. To Display	Type of Setpoint	Comments	SEC to Ignore Safety	Window to Ext. Safety Time(SEC)	Safety Time Extension (SEC)
9	TARG/S STOP	12	8	20	0.1	2	5	0	0	Active	... TEMP	Factory L1	Time	
10	FAST CTL ZN	2	1.6	3	0.1	1	1	0	0	Active	... TEMP	Factory L1	Time	
11	EXV LD/UNLD%	0	0	0.5	0.1	0	10	0	0	Active	... HUMD or %	Factory L1	Time	
12	SH MPL/SPRD	1	1	3	1	5	10	0	0	Active	... DIGITAL/SW	Factory L1	Time	
13	RDC MPY/LSUC	1	1	3	1	4	15	0	0	Active	... DIGITAL/SW	Factory L1	Time	
14	LIMIT ADJUST	0.2	0.1	0.4	0.1	3	6	0	0	Active	... DECINCH	Factory L1	Time	
15	VMIN/LSH MPY	3	2	25	1	2	15	0	0	Active	... HUMD or %	Factory L1	Time	
16	VMAX	100	50	100	1	0	0	0	0	Active	... HUMD or %	Factory L1	Setpoint	
17	LD SUPERHEAT	3	1	5	0.1	120	300	2	10	Active	... TEMP	Factory L1	Alarm		... 0	300	120
18	LSUC/LSH DLY	1	1	10	1	1	10	0	0	Active	... SECONDS	Factory L1	Time	
19	E DLY/S CALC	1	1	30	1	10	10	0	0	Active	... SECONDS	Factory L1	Time	
20	E STRT/C DLY	126	1	270	1	8	15	0	0	Active	... SECONDS	Factory L1	Time	

23.5. Set Point Descriptions (Fast SSH & Fast SSH2)

Fast SSH set points **Available in MCS release 17.26-B and later**

Fast SSH2 set points **Available in MCS release 17.41 and later**

SP #	Name	Description
9	EXV Target	(Value Field) – This is the superheat target the system will make adjustments to the Electronic Expansion Valve to maintain. (Time Field) – In Fast SSH when in low suction psi this is the number of seconds the suction psi must be increasing before the systems stops adjusting the valve. (Time Field) - In Fast SSH2 it is the number of seconds to calculate the extended slope. When in low suction, adjustments are stopped when the suction pressure slope is positive for 1 second.
10	EXV Fast Zone	((Value Field) – The system makes adjustments to the EXV Valve percentage to maintain the superheat within this range. (Time Field) – The Time Field is not used.
11	EXV Adjustment made when a modulating compressor’s capacity changes	(Value Field) – The opening adjustment that is made to the EXV current valve % when the circuit changes to the loading state or the closing adjustment that is made when the circuit changes to the unloading state. When in the MOP hold state, only closing adjustments are allowed. (Time Field) – When > zero it is used to increase the hold time.
12	Super Heat adjust multiplier	(Value Field) – This value is used to multiply times the calculated value of superheat target – current superheat target value. (The difference from where we want to be verses where we are) (Time Field) – The maximum different between two EXV’s on the same circuit allowed once out of startup and under control.

13	Rate of Change adjust multiplier	<p>(Value Field) - This value is used to multiply times the calculated value of current superheat – the superheat value one second ago. (The slope of the current superheat)</p> <p>Time Field) – If set point type = 'Time' and Time Field is ≥ 2 and ≤ 100 this is the adjustment multiplier for when the system is in Low Suction. It takes the base valve adjustment of 0.5% and multiplies it with this value. Adjustments stop when the suction psi starts too increase. (See set point 9 time field for additional information.) If the conditions are not met then a value of 0.5 is used. (Delay between adjustments is specified in the value field of SP 17.)</p>
14	Limit of Adjustment	<p>(Value Field) – In FSH this value limits the adjustment while the superheat is $<$ then the Fast Zone times two. In FSH2 this value is the maximum limit of the adjustment.</p> <p>(Time Field) - In FSH this value is the limit of adjustment when the superheat $>$ then two times the Fast Zone. Remember in the value field of this set point you are typically using a value of 0.2 to 0.5. In the time field a value of 7 is equivalent to 0.7.</p> <p>(Time Field) - In FSH2 this field is not used.</p>
15	Minimum EXV Valve %	<p>(Value Field) – The minimum position of the valve. Usually 3%. Will need to be larger if hot gas is on system.</p> <p>(Time Field) - The adjustment multiplier for when the system is in Low Superheat.</p>
16	Maximum EXV Valve %	<p>(Value Field) – The maximum position of the valve allowed. Usually 100%. Sometimes used if valve is oversized.</p> <p>(Time Field) – Not Used</p>
17	Low Superheat	<p>(Value Field) – If the superheat falls below this value and stays below for longer than the number of seconds specified in the Time Field, of this set point, the system will enter a safety, generate an alarm and shut off this compressor then restart if required. If this specifies a lockout then it will follow the lockout rules. In FSH and FSH2 the system will take corrective action to correct this potential problem.</p> <p>(Time Field) – Timer for this set point as described.</p>
18	Low Psi Delay	<p>(Value Field) – The value specifies the number of seconds between valve adjustments, (for Low Suction) trying to correct this situation. Adjustments will continue until the slope of the suction pressure starts to increase.</p> <p>(Time Field) – This value specifies the number of seconds delay between adjustments, (for Low Superheat) trying to correct this situation. Adjustments continue until the superheat is above the Value Field.</p>
19	EXV Delay	<p>(Value field) – The value in this field is decremented by the difference between the absolute value of the current superheat – superheat target. When the result reaches zero the FSH & FSH2 make the current calculated adjustment to the current valve percentage.</p> <p>(Time Field) – The value in the time field determines when control will begin when two EXV's are on the same circuit. This value times the value field in the fast zone plus the current target defines when control is taken, at startup. If this value is 10 and the value in the fast zone is 2 and the target is 12 the result would be $(10 * 2 + 12) = 32\%$. When both valves are \leq this % control is taken and then kept within the value specified in the time field of set point 12.</p>
20	EXV Startup Time	<p>(Value Field) – EXV starting time in seconds. The following decisions are made on taking control:</p> <ol style="list-style-type: none"> If the current superheat is $>$ target + 5.0 ° & State timer $>$ Startup time / 2 Take control. If the current superheat is $<$ target – Fast zone & State timer $>$ Startup time / 2 Take Control. If the Suct psi is $<$ Low Suct SP + Low unload & State timer $>$ Startup time / 2 Take Control. If the EXV startup time ≥ 90 & a) or b) is true adjust the valve start percentage

23.5.1 Set Point Adjustments

Fast SSH & Fast SSH2 Common adjustments

When using FSH or FSH2 you should not experience a low suction or low superheat alarm unless you are low on refrigerant or have a mechanical problem. (If you bring on too much condenser that causes the head psi to drop too quickly it will also pull the suction psi with it.) Set the multiplier of SP 13 'Time Field' to a value high enough to recover from a low suction.

23.5.2 Low Suction Multiplier-SP 13

'Time Field' is a multiplier for the change being made to adjust for a Low Suction condition. The MCS Default is 2. If a low suction occurs and the system does not recover in time, an a low suction alarm occurs increase SP 13 Time Field by 1.

If a low suction occurs and the system over corrects, (that is the EXV valve opens more than is required) then reduce SP 13 Time Field by 1.

If an alarm occurs you can increase the multiplier and or decrease the time delay between adjustments. (Set Point 18 Value Field)

23.5.2.1. Low Superheat Adjustment-SP 15

'Time Field' is a multiplier for the change being made to adjust for a Low Superheat condition. The MCS Default is 2.

If a low superheat occurs and the system over corrects, (the EXV valve closes more than is required) then reduce SP 15 Time Field by 1.

If an alarm occurs you can increase the multiplier and or decrease the time delay between adjustments. (Set Point 18 Time Field)

23.5.2.2. EXV Startup Time-SP 20

'Value Field' specifies the maximum time the valve will remain in the EXV Startup State. If the value is less than 90 seconds the Magnum will remain in this state for the entire time specified unless it reaches one of the startup exit conditions covered in SP 20. It is not recommended to make this value less than 25 seconds.

If the value is ≥ 90 the Magnum will calculate a new valve opening percentage, if required. When setting a value of 90, or greater it is recommended it be in increments of 9 for Fast SSH. For Fast SSH the Magnum starts evaluating it's position after 44% of its startup time has passed. In Fast SSH2 it starts evaluation after 50% of its startup time has passed.

23.5.2.3. EXV Compressor Start Delay-SP 20

'Time Field' specifies the number of seconds to delay starting the compressor to allow the valve to partially open. MCS recommends 8 to 10 seconds and not more than 15 seconds. Remember this is part of the EXV startup time.

23.5.2.4. EXV Target & EXV Fast Zone-SP 9

'Value Field' specifies the superheat target we want to achieve and SP 10 'Value Field' specifies the Control Zone we are maintaining. The table shows the MCS recommendations for both English and Metric.

Units	English			Metric		
	Low	Standard	High	Low	Standard	High
Superheat	10.0	12.0	14.0	5.6	6.7	7.8
Fast Zone	1.6	2.0	3.0	0.9	1.1	1.7

23.6. Fast SSH States

Listed below shows the format of the states used.

EXV-AA-BB-CCCC

AA	DESC.	BB	DESC	CCCC	DESC.
HD	HOLDING	>T	GREATER TARG	RcSm	RATE OF CHANGE SMALL
OP	OPENING	<T	LESS TARG	RcLg	RATE OF CHANGE LARGE
CL	CLOSING	Sh	SUPERHEAT	ShHi	SUPERHEAT HIGH
				ShSm	SUPERHEAT SMALL
				Rc=0	RATE OF CHANGE EQUALS ZERO
				InDb	IN DEAD BAND
				InZn	IN ZONE

23.6.1 FAST SSH2 State Format

Listed below shows the format of the states used.

EXV-AA-BB-CCCC

AA	DESC.	BB	DESC	CCCC	DESC.
HD	HOLDING	>T	GREATER TARG	EsLo	EXTENDED SLOPE LOW
OP	OPENING	<T	LESS TARG	EsHi	EXTENDED SLOPE HIGH
CL	CLOSING	Es	EXTENDED SLOPE	0 OR 1	EXTENDED SLOPE IS 0 OR 1
		Sh	SUPERHEAT	= T	SUPERHEAT EQUALS TARGET
				ShHi	SUPERHEAT HIGH
				ShLo	SUPERHEAT LOW
				St=5	STATE TIMER EQUALS 5
				RcSm	RATE OF CHANGE SMALL
				RcLg	RATE OF CHANGE LARGE
				Rc=0	RATE OF CHANGE EQUALS ZERO
				InDb	IN DEAD BAND
				InZn	IN ZONE

Chapter - 24. General Introduction to EXV PID

24.1. MCS PID REQUIREMENTS

- FIRMWARE 17.60E4 or greater
- MCS-CONNECT 18.26.11 or greater
- MCS-CONFIG 18.01N or greater

- An EXV PID controller uses information about: PRESENT, PAST and errors to adjust the Expansion Valve.
- EXV PID automatically applies accurate and responsive correction to a control function.

P	PROPORTIONAL (Kp)	Change in Superheat = Current Superheat minus last Superheat from 1 second ago (Rate of Change)
I	INTEGRAL (Ki)	Offset in Superheat = Current Superheat minus Target Superheat (setpoint #9 value field)
D	DERIVATIVE (Kd)	Velocity of Superheat = Current Superheat minus the Superheat from x seconds ago (setpoint #9 time seconds value)
A	ACCELERATION (Ka)	Change in Velocity = Current Kd minus the Kd from x seconds ago (setpoint #9 time seconds value)

24.2. Calculations for the adjustment to EXV valve

MCS EXV PID algorithm uses two different sets of K multipliers to calculate adjustments to EXV on how far the superheat is from the superheat target, (setpoint #9 value field).

FAST multipliers

SLOW multipliers

#	SetPoints	Value	Time	SEC Ig...	windo...	safety ...	HI zone	LOW z...	Setback
1	COOL TARGET	46.0F	----	----	----	----	----	----	----
2	CTRL ZONE+	0.5F	----	----	----	----	----	----	----
3	CTRL ZONE-	0.5F	----	----	----	----	----	----	----
8	CHAM LIQ INJ	180.0F	----	----	----	----	----	----	----
9	SucSprHtTarg	12.0F	6 S	----	----	----	4.0F	3.5F	0.0F
10	Ki-IntegMult	0.10	0 S	----	----	----	2.20	-2.20	0.10
12	Kp-PropMult	0.30	0 S	----	----	----	0.00	0.00	0.20
13	Kd-DerrMult	0.17	0 S	----	----	----	0.20	-0.20	0.17
14	Ka-AccMult	0.10	0 S	----	----	----	0.00	0.00	0.00
15	ExvMinValve%	5.0%	----	----	----	----	----	----	----
16	ExvMaxValve%	100....	0 S	----	----	----	0.0%	0.0%	15.0%
17	LoSucSuperHt	3.5F	120 S	15	300	60	----	----	----
19	ExvKiDelay	30s	----	----	----	----	----	----	----
20	ExvStartup	10s	5 S	----	----	----	----	----	----

FAST multipliers

SLOW multipliers

PID multipliers setpoints

24.3. EXV PID Firmware

Uses information about: PRESENT, PAST and errors to adjust the Expansion Valve.

- Provides extremely fast reaction to changes in superheat caused in part by the following:
 - High ambient chiller running in low ambient conditions.
 - Condenser fans turning on or off creating large changes in discharge and suction pressure .
 - Subcooling going temporarily negative and not having a solid column of liquid for short periods.
 - Large subcooler / economizers coming on and off.

EXV PID Logic supports:

- Suction Superheat, Discharge Superheat, Evaporator Level and Condenser Level Control.

24.4. MCS PID REQUIREMENTS

- FIRMWARE 17.60E4 or greater
- MCS-CONNECT 18.26.11 or greater
- MCS-CONFIG 18.01N or greater

24.5. Selecting PID in MCS-CONFIG

In PID only setpoints 9 through 20 are used to control the EXV valve. If you select PID as your superheat EXV control and you have a subcooler (an economizer injecting refrigerant into the compression chamber) you will get PIP control on the EXV for the subcooler. The PID set points for the subcooler are 65 through 72. Select Type of Control in Relay Output Information Screen. In the RO screen, from the drop down window in 'Type' you select either 'Step w \ EXV' or 'Screw w \ EXV'.

Relay Output Information Screen									
Point Number	Name	Slide Mult.	Slide Div.	Slide Off.	Design Suc.PSI	Design Dis.PSI	Nominal Tonnage(of Step)	EXV Start (When Lead)	Type
4-1	COMP 1	---	---	---	---	---	0	35	Step w \ EXV
4-2	CHAM INJ 1	---	---	---	---	---	---	---	Standard
4-3	ECONO 1	---	---	---	---	---	0	20	Step w \ EXV
4-4	REV VLV 1	---	---	---	---	---	---	---	Standard

24.6. Circuit Base

In the Circuit Base screen you need to select the Analog Output for the EXV.

Select Output and Sensor Inputs per circuit									
Circuit # (reset button)	Alarm Relay	Comp Proof	Compr Speed(%) or Modulate Hot Gas AN	Compressor Speed Fault	Slide Closed Indicator	Pump Down	Evaporator EXV Output	Flow	
1	Not Used	Not Used	COMP1 SPD	Cmp1VrdFl	Not Used	DISABLE 1	Exv#1-PID	COMP1 FLO	N
2	Not Used	Not Used	COMP2 SPD	Cmp2VrdFl	Not Used	DISABLE 2	RO		N
3	Not Used	Not Used	Not Used	Not Used	Not Used	Not Used	SPARE7-5		W
4	Not Used	Not Used	Not Used	Not Used	Not Used	Not Used	SPARE7-6		W
5	Not Used	Not Used	Not Used	Not Used	Not Used	Not Used	SPARE7-7		W
6	Not Used	Not Used	Not Used	Not Used	Not Used	Not Used	SPARE7-8		W
7	Not Used	Not Used	Not Used	Not Used	Not Used	Not Used	SPARE7-9		W
8	Not Used	Not Used	Not Used	Not Used	Not Used	Not Used	SPARE7-10		W
							COMP1 SPD%		
							COMP2 SPD%		
							Exv#1-PID		



Next in the Circuit Base screen you need to select 'PIP SSH' from the Evaporator EXV Control section drop down menu.

NOTE: TANDEM 6 EXV PER CIRCUIT NOT SUPPORTED IN RTU AND CENTRIFUGAL FIRMWARE

Information that relates to Condensers and Evaporators on the circuit										
Starting condenser Fault	# Cond Faults	Cond Fan Bank	Condenser Coil Temp #1	Condenser Coil Temp #2	Tandem EXV Circuit #	EXV #3 Circuit#	EXV #4 Circuit#	EXV #5 Circuit#	EXV #6 Circuit#	Evaporator EXV Control
Used	0	1	Not Used	Not Used	1	1	1	1	1	PID Cond Lvl
Used	0	2	Not Used	Not Used	2	2	2	2	2	PID Cond Lvl

The MAGNUM supports up to 6 tandem EXVs per circuit.
NOT AVAILABLE with RTU and Centrifugal firmware

With the release of Fast SSH2 AND PID MCS has released a new MCS-Config to support the new functions. The new MCS-Config provides a new tab, 'EXV Control', where you define your system. This then allows MCS-Config to provide MCS Default Set Point Values for you. The figure below shows the Current 'Circuit Base' tab and the new 'EXV Control' tab.

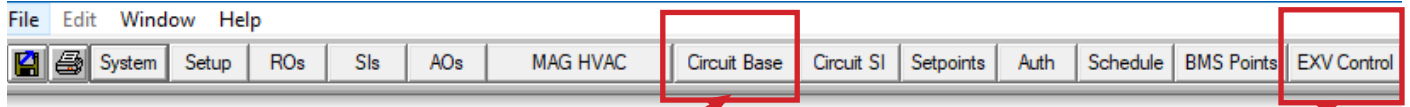

If you enter data in the EXV portion of the Circuit Base tab or in the EXV Control tab it is carried through to the other tab.

24.7. Selecting the 'EXV Control' tab you are prompted with the following:

Selection Option →
(Evaporator and condenser Level not available with Fast I or Fast II Control Method)

EXV Control Wizard

Control Parameter

- Suction Superheat
- Discharge Superheat
- Evaporator Level
- Condenser Level
- Approach

Heat Exchanger Type

- None
- DX Coil
- Plate HX
- DX Barrel
- Flooded Barrel

Control Method

- Normal (Original)
- Fast I
- Fast II
- PID

Target Modifier

- Low Discharge Superheat
- Oversized Condenser/High Ambient
- Maximum Operating Pressure(MOP)
- Minimum Differential Pressure(MDP)
- Target Reset
- Low Suction
- Low/High Level
- Level->CAP

Set Default Values?
Firmware Version 17.56 or Higher Required

EXV Control Setpoints																
#	Name	Value	Min	Max	Adjust Value	Time (SEC)	Max Time Allowed (SEC)	Lockout Delay (HRS)	Safety Down Time(MIN)	Active or Non-Active	Select Value: # decimals & print char	Level Of Auth. To Display	Type of Setpoint	Comments	SEC to Ignore Safety	Win Est. Time
9	SucSprHTTarg	12	8	20	0.1	6	9	0	0	Active	... TEMP	Service L	Target			
10	Ki-IntegMult	0.15	0	3	0.01	0	0	0	0	Active	... DEC2NOCH	Service L	Target			
11	EXV LD/UNLD%	0	0	0.5	0.1	0	0	0	0	Non-Active	... HUMD or %	Service L	Time			
12	Kp-PropMult	0.3	0	3	0.01	0	0	0	0	Active	... DEC2NOCH	Service L	Target			
13	Kd-DerivMult	0.2	0	3	0.01	0	0	0	0	Active	... DEC2NOCH	Service L	Target			
14	Ka-AccelMult	0.1	0	3	0.01	0	0	0	0	Active	... DEC2NOCH	Service L	Target			
15	ExvMinValve%	5	2	25	1	2	10	0	0	Active	... HUMD or %	Service L	Setpoint			
16	ExvMaxValve%	100	50	100	1	0	0	0	0	Active	... HUMD or %	Service L	Target			
17	LD SUPERHEAT	3.5	2	4	0.1	120	180	2	10	Active	... TEMP	Service L	Lockout		15	300
18	LOW PSI DELY	1	1	30	1	3	60	0	0	Non-Active	... SECONDS	Service L	Time			
19	ExvKiDelay	15	1	120	1	0	0	0	0	Active	... SECONDS	Service L	Setpoint			
20	ExvStartup	10	5	45	1	5	10	0	0	Active	... SECONDS	Service L	Time			

Compressor EXV Results →

Based on your selections will dictate the set points for compressor control.

24.8. Selection Options

Superheat Control based on ?

Superheat Control method type ?

Config Creation or reset to MCS Defaults

EXV Control Wizard

Control Parameter

- Suction Superheat
- Discharge Superheat
- Evaporator Level
- Condenser Level
- Approach

Heat Exchanger Type

- None
- DX Coil
- Plate HX
- DX Barrel
- Flooded Barrel

Control Method

- Normal (Original)
- Fast I
- Fast II
- PID

Target Modifier

- Low Discharge Superheat
- Oversized Condenser/High Ambient
- Maximum Operating Pressure(MOP)
- Minimum Differential Pressure(MDP)
- Target Reset
- Low Suction
- Low/High Level
- Level->CAP

Set Default Values?
Firmware Version 17.56 or Higher Required

Evaporator Type being controlled ?

Functions Effecting Superheat control. Some require set points to be active



NOTE: Once you have clicked on the boxes for your setup, be sure to click on **'Set Values to Default'**. This will set the values to the default for **'Control Parameter, Heat Exchanger Type and the Control Method'**. **Make note that clicking in the 'Target Modifier' require that some set points must be active.**

24.9. Compressor EXV Results

EXV Control Setpoints																	
#	Name	Value	Min	Max	Adjust Value	Time (SEC)	Max Time Allowed (SEC)	Lockout Delay (HRS)	Safety Down Time(MIN)	Active or Non-Active	Select Value: # decimals & print char	Level Of Auth. To Display	Type of Setpoint	Comments	SEC to Ignore Safety	Window to Ext. Safety Time(SEC)	Safety Time Extension (SEC)
9	SucSprHtTarg	12	8	20	0.1	6	9	0	0	Active	... TEMP	Service L	Target		...	-----	-----
10	Ki-IntegMult	0.15	0	3	0.01	0	0	0	0	Active	... DEC2NOCH	Service L	Target		...	-----	-----
11	EXV LD/UNLD%	0	0	0.5	0.1	0	0	0	0	Non-Active	... HUMD or %	Service L	Time		...	-----	-----
12	Kp-PropMult	0.3	0	3	0.01	0	0	0	0	Active	... DEC2NOCH	Service L	Target		...	-----	-----
13	Kd-DerivMult	0.2	0	3	0.01	0	0	0	0	Active	... DEC2NOCH	Service L	Target		...	-----	-----
14	Ka-AccelMult	0.1	0	3	0.01	0	0	0	0	Active	... DEC2NOCH	Service L	Target		...	-----	-----
15	ExvMinValve%	5	2	25	1	2	10	0	0	Active	... HUMD or %	Service L	Setpoint		...	-----	-----
16	ExvMaxValve%	100	50	100	1	0	0	0	0	Active	... HUMD or %	Service L	Target		...	-----	-----
17	LO SUPERHEAT	3.5	2	4	0.1	120	180	2	10	Active	... TEMP	Service L	Lockout		... 15	300	60
18	LDW PSI DELY	1	1	30	1	3	60	0	0	Non-Active	... SECONDS	Service L	Time		...	-----	-----
19	ExvKiDelay	15	1	120	1	0	0	0	0	Active	... SECONDS	Service L	Setpoint		...	-----	-----
20	ExvStartup	10	5	45	1	5	10	0	0	Active	... SECONDS	Service L	Time		...	-----	-----

- Control on 'Suction Superheat'
- Evaporator Type 'Plate HX'
- Control Method 'PID'
- MCS Default 'Selected'
- Degrees F or C are automatic

24.10. Set Point Descriptions (PID)

Set points Available in MCS release 17.26-B and later

SP #	Name	Description
9	SPRHT TARGET or LEVEL TARGET	If EXV control is based upon superheat, this is the Superheat target that the Magnum will control from. If EXV control is based upon refrigerant level, this is the refrigerant level target that the Magnum will control from. 'Low Zone' if nonzero then develop control super heat based upon the lowest superheat of any compressor that is on with in this suction group else use the superheat of this compressor. 'Time (sec)' field: Seconds between samples used for calculating the Superheat Rate of Change.
	STAGE 7 CUT IN (Cut In/Out Control)	Stage 7 cut in, Setpoint value contains the voltage when this stage is turned on.
10	SPRHT ZONE +-	The value in this setpoint is added and subtracted to setpoint #9 to determine the upper and lower limits of the control zone respectively. Refer to section on EXV control. 'Time (sec)' field: If non-zero, skip ROC adjustment logic in the control zone.
	STAGE 8 CUT IN (Cut In/Out Control)	Stage 8 cut in, Setpoint value contains the voltage when this stage is turned on.
11	EXV LOAD ADJ	The opening adjustment that will be made to the EXV percentage when the circuit changes to the Loading state or the closing adjustment that will be made when the circuit changes to the Unloading state. Refer to section on EXV control. Note: In MOP hold state, only closing adjustments are allowed.

14	Limit of Adjustment	<p>(Value Field) – In FSH this value limits the adjustment while the superheat is < then the Fast Zone times two. In FSH2 this value is the maximum limit of the adjustment.</p> <p>(Time Field) - In FSH this value is the limit of adjustment when the superheat > then two times the Fast Zone. Remember in the value field of this set point you are typically using a value of 0.2 to 0.5. In the time field a value of 7 is equivalent to 0.7.</p> <p>(Time Field) - In FSH2 this field is not used.</p>
15	Minimum EXV Valve %	<p>(Value Field) – The minimum position of the valve. Usually 3%. Will need to be larger if hot gas is on system.</p> <p>(Time Field) - The adjustment multiplier for when the system is in Low Superheat.</p>
16	Maximum EXV Valve %	<p>(Value Field) – The maximum position of the valve allowed. Usually 100%. Sometimes used if valve is oversized.</p> <p>(Time Field) – Not Used</p>
17	Low Superheat	<p>(Value Field) – If the superheat falls below this value and stays below for longer than the number of seconds specified in the Time Field, of this set point, the system will enter a safety, generate an alarm and shut off this compressor then restart if required. If this specifies a lockout then it will follow the lockout rules. In FSH and FSH2 the system will take corrective action to correct this potential problem.</p> <p>(Time Field) – Timer for this set point as described.</p>
18	Low Psi Delay	<p>(Value Field) – The value specifies the number of seconds between valve adjustments, (for Low Suction) trying to correct this situation. Adjustments will continue until the slope of the suction pressure starts to increase.</p> <p>(Time Field) – This value specifies the number of seconds delay between adjustments, (for Low Superheat) trying to correct this situation. Adjustments continue until the superheat is above the Value Field.</p>
19	EXV Delay	<p>(Value field) – The value in this field is decremented by the difference between the absolute value of the current superheat – superheat target. When the result reaches zero the FSH & FSH2 make the current calculated adjustment to the current valve percentage.</p> <p>(Time Field) – The value in the time field determines when control will begin when two EXV's are on the same circuit. This value times the value field in the fast zone plus the current target defines when control is taken, at startup. If this value is 10 and the value in the fast zone is 2 and the target is 12 the result would be $(10 * 2 + 12) = 32\%$. When both valves are \leq this % control is taken and then kept within the value specified in the time field of set point 12.</p>
20	EXV Startup Time	<p>(Value Field) – EXV starting time in seconds. The following decisions are made on taking control:</p> <ol style="list-style-type: none"> If the current superheat is $>$ target + 5.0 ° & State timer $>$ Startup time / 2 Take control. If the current superheat is $<$ target – Fast zone & State timer $>$ Startup time / 2 Take Control. If the Suct psi is $<$ Low Suct SP + Low unload & State timer $>$ Startup time / 2 Take Control. If the EXV startup time \geq 90 & a) or b) is true adjust the valve start percentage

24.11. PID Example Setpoint Defaults

Default **Celsius** values for Suction Superheat with DX Chiller Barrel.

#	SETPOINT	VALUE	TIME	SEC Ignore	WINDOW EXT	SAFETY EXT	HI ZONE	LOW ZONE	SETBACK	TYPE
9	SucSprHtTarg	6.5C	6 S	-	-	-	3.0C	2.7C	0.0C	TARGET
10	Ki-IntegMult	0.20	0 S	-	-	-	2.20	-2.20	0.10	TARGET
12	Kp-PropMult	0.45	0 S	-	-	-	0.00	0.00	0.20	TARGET
13	Kd-DerrMult	0.15	0 S	-	-	-	0.20	-0.20	0.17	TARGET
14	Ka-AccMult	.10	0 S	-	-	-	0.00	0.00	0.00	TARGET
15	ExvMinValve%	5.0%	-	-	-	-	-	-	-	SETPOINT
16	ExvMaxValve%	100	0 S	-	-	-	0.0%	0.0%	15.0%	TARGET
17	LO SUPERHEAT	1.6F	120 S	15	300	60	-	-	-	LOCKOUT
19	ExvKiDelay	15s	-	-	-	-	-	-	-	SETPOINT
20	ExvStartup	10s	5 S	-	-	-	-	-	-	TIME

Below setpoints are the default **Fahrenheit** values for Suction Superheat with DX Chiller Barrel.

#	SETPOINT	VALUE	TIME	SEC Ignore	WINDOW EXT	SAFETY EXT	HI ZONE	LOW ZONE	SET-BACK	TYPE
9	SucSprHtTarg	12.0F	6 S	-	-	-	4.0F	3.5F	0.0F	TARGET
10	Ki-IntegMult	0.15	0 S	-	-	-	2.20	-2.20	0.10	TARGET
12	Kp-PropMult	0.30	0 S	-	-	-	0.00	0.00	0.20	TARGET
13	Kd-DerrMult	0.20	0 S	-	-	-	0.20	-0.20	0.17	TARGET
14	Ka-AccMult	0.10	0 S	-	-	-	0.00	0.00	0.00	TARGET
15	ExvMinValve%	5.0%	-	-	-	-	-	-	-	SETPOINT
16	ExvMaxValve%	100	0 S	-	-	-	0.0%	0.0%	15.0%	TARGET
17	LO SUPERHEAT	3.5F	120 S	15	300	60	-	-	-	LOCKOUT
19	ExvKiDelay	15s	-	-	-	-	-	-	-	SETPOINT
20	ExvStartup	10s	5 S	-	-	-	-	-	-	TIME

24.12. Logic to Determine which K Multipliers to Use

- Calculations are done every second

24.12.1.1. Switching to Fast K multipliers is based on:

a. Distance from target

- If current superheat is greater than (setpoint #9 value field plus setpoint #9 high zone field x 2)

Setpoint	Value		Hi Zone		Total
#9 SucSprHtTarg	12.0F	+	4.0F x 2	=	20

EXV PID algorithm will use the fast multipliers (Setpoint Value Field)

- If current superheat value is less than (setpoint #9 value field minus setpoint #9 high zone field)

Setpoint	Current Superheat Value		HI Zone		Total
#9 SucSprHtTarg	12.0F	-	4.0F	=	8

EXV PID algorithm will use the fast multipliers (Setpoint Value Field)

#	SetPoints	Value	Time	SEC Ig...	windo...	safety ...	HI zone	LOW z...	Setback
9	SucSprHtTarg	12.0F	6 S	----	----	----	4.0F	3.5F	0.0F
10	Ki-IntegMult	0.10	0 S	----	----	----	2.20	-2.20	0.10
12	Kp-PropMult	0.30	0 S	----	----	----	0.00	0.00	0.20
13	Kd-DerrMult	0.17	0 S	----	----	----	0.20	-0.20	0.17
14	Ka-AccMult	0.10	0 S	----	----	----	0.00	0.00	0.00

FAST multipliers

24.12.1.2. Switching to Slow K multipliers is based on:

b. Distance from target

- If current superheat is less than (setpoint #9 value field plus setpoint #9 low zone field) but above the fast multiplier switch of 8 (12 - 4)

Setpoint	Value		LOW Zone		Total
#9 SucSprHtTarg	12.0F	+	3.5F	=	15.5F

EXV PID algorithm will use the slow multipliers (Setback Value Field)

- If current superheat is more than (setpoint #9 value field minus setpoint #9 low zone field) and below the fast multiplier switch of 20 (12 + 4 x 2)

Setpoint	Value		LOW Zone		Total
#9 SucSprHtTarg	12.0F	-	3.5F	=	8.5

EXV PID algorithm will use the slow multipliers (Setback Value Field)

#	SetPoints	Value	Time	SEC Ig...	windo...	safety ...	HI zone	LOW z...	Setback
9	SucSprHtTarg	12.0F	6 S	----	----	----	4.0F	3.5F	0.0F
10	Ki-IntegMult	0.10	0 S	----	----	----	2.20	-2.20	0.10
12	Kp-PropMult	0.30	0 S	----	----	----	0.00	0.00	0.20
13	Kd-DerrMult	0.17	0 S	----	----	----	0.20	-0.20	0.17
14	Ka-AccMult	0.10	0 S	----	----	----	0.00	0.00	0.00

SLOW multipliers

24.12.1 Rate of Change_- Moving too Fast

1. If current superheat ROC is greater than setpoint #13 (Kd) high zone and current superheat is above target

Current Superheat ROC	Setpoint #13 High Zone	Current Superheat
0.7	.20	16F

EXV PID algorithm will use the fast multipliers (Setpoint Value Field)

2. If current superheat ROC is greater than setpoint #13 (Kd) low zone and current superheat is below target

Current Superheat ROC	Setpoint #13 Low Zone	Current Superheat value
-0.3	-0.20	8

EXV PID algorithm will use the fast multipliers (Setpoint Value Field)

#	SetPoints	Value	Time	SEC Ig...	windo...	safety ...	HI zone	LOW z...	Setback
9	SucSprHTarg	12.0F	6 S	-----	-----	-----	4.0F	3.5F	0.0F
10	Ki-IntegMult	0.10	0 S	-----	-----	-----	2.20	-2.20	0.10
12	Kp-PropMult	0.30	0 S	-----	-----	-----	0.00	0.00	0.20
13	Kd-DerrMult	0.17	0 S	-----	-----	-----	0.20	-0.20	0.17
14	Ka-AccMult	0.10	0 S	-----	-----	-----	0.00	0.00	0.00

FAST multipliers

24.12.2 Rate of Change - Moving Slow Enough

If current superheat ROC is less than setpoint #13 (Kd) high zone and current superheat is above target

Current Superheat ROC	Setpoint #13 High Zone	Current Superheat
0.1	0.20	15F

EXV PID algorithm will use slow multipliers (Setback Field)

If current superheat ROC is less than setpoint #13 (Kd) low zone and current superheat is below target

Current Superheat ROC	Setpoint #13 Low Zone	Current Superheat
-0.1	-0.20	10

EXV PID algorithm will use slow multipliers (Setback Field)

#	SetPoints	Value	Time	SEC Ig...	windo...	safety ...	HI zone	LOW z...	Setback
9	SucSprHTarg	12.0F	6 S	-----	-----	-----	4.0F	3.5F	0.0F
10	Ki-IntegMult	0.10	0 S	-----	-----	-----	2.20	-2.20	0.10
12	Kp-PropMult	0.30	0 S	-----	-----	-----	0.00	0.00	0.20
13	Kd-DerrMult	0.17	0 S	-----	-----	-----	0.20	-0.20	0.17
14	Ka-AccMult	0.10	0 S	-----	-----	-----	0.00	0.00	0.00

SLOW multipliers

24.13. MCS-Connect Evaporator EXV PID Status

Proportional Adjustment
(Current Superheat minus Superheat from last second) x Kp
Kp = setpoint #12/#67 value (fast) or setback value (slow)

Acceleration Adjustment
(Current Kd minus Kd from x seconds ago) x Ka
Ka = setpoint #14/#69 value (fast) or setback value (slow)

Total Adjust
Adjustment made to current EXV position

Controlling parameter (Callout to WTR OUT = 47.7F)

State	Time	PSI Diff	FLA %	Steps	Lead?	Manual Speed %	Condenser Adjustment
1) CMP IS RUNNING	00:42:43	86.1P	36%	1		N/A	-
2) SWITCHED OFF	23:47:26	-9.3P	0%	0	Yes	N/A	-

Evap EXV State	Time	Valve %	Control On Suct Supht	SuperHeat ROC	ADJ Delay	EXV Target (Adjusted)	Prop. Adj.	Int. Adj.	Der. Adj.	Accel. Adj.	Total Adj.	Kp	Ki	Kd
1) EXV IS OPENING	00:00:03	51.8%	15.5	0.7	15	12.0	0.00	0.00	0.17	0.02	0.1	0.50	0.10	0.25
2) EXV IS CLOSED	00:49:14	0.0%	18.3	-0.1	0	12.0	0.00	0.00	0.00	0.00	0.0	1.00	0.10	0.25

Integral Adjustment
(Current Superheat minus Superheat Target setpoint #9 value) x Ki
Ki = setpoint #10/#66 value (fast) or setback value (slow)

Derivative Adjustment
(Current Superheat minus Superheat from x seconds ago) x Kd
Kd = setpoint #13/#68 value (fast) or setback value (slow)

Current K multipliers being used

24.14. Allowing an Adjustments to the EXV Valve

(When Ki & Kd are in opposite, we are going in the right direction)

1. When the Proportional adjust, Integral adjust, Derivative adjust and Acceleration all add up to be \geq to .1 or \leq -.1, the adjustment is made based on that number.
2. The Proportional adjust, Derivative adjust and Acceleration all run every second.
3. The Integral adjust uses setpoint #19 (ExvKiDelay) as a delay before posting a value as long as;
 - a. If the current Integral adjust (Ki) is > 0 and the current superheat $>$ the current target plus setpoint #10 high zone field.
 - b. If the current Integral adjust (Ki) is < 0 and the target superheat $<$ the current target plus setpoint #10 low zone.

Ki adjust HiZone
12 plus 2.20 = 14.2

14.2°F

12°F Superheat Target

9.8°F

Ki adjust LOW zone
12 plus -2.20 = 9.8

No
Ki
Adjust in
this area

#	SetPoints	Value	Time	SEC Ig...	windo...	safety ...	HI zone	LOW z...	Setback	MIN VFD	MAX VFD	MAX V...	Type
9	SucSprHtTarg	12.0F	6 S	----	----	----	4.0F	3.5F	0.0F	----	----	----	TARGET
10	Ki-IntegMult	0.10	0 S	----	----	----	2.20	-2.20	0.10	----	----	----	TARGET

Chapter - 25. EXV Level Control using PID

- The following versions of Firmware are needed to setup EXV Level Control:
- MCS-CONFIG – 17.17.00U or later
- MCS-CONNECT – 17.003.11 or later
- MCS-MAGNUM Firmware - 17.16C or later

25.1. Setting up EXV Level Control

- Setup Analog Outputs to control electronic expansion valves.

Analog Output Information Screen									
Point Number	Name	Control Type	Invert	Comments	Modbus Display Type	Feedback Sensor			
M-1	EEV-1	Standard	NO		Spare	Not Used			
M-2	EEV-2	Standard	NO		Spare	Not Used			

- Setup INPUTS to read evaporator or condenser level.

Sensor Input Information Screen									
Point Number	Name (1 to 10 char)	Display Type	Offset	Manual Value or NC/NO (select to change)	Display Text (select to change)	Temp. / GPM / CFM / Pwr Factor SI	Humd./PSI/ Temp. Diff. / Enthal. Diff.	Auto/Manual (Click here for all)	Circuit Index
1-12	REFLVL1	User Defined	0	0	Not Used	Not Used	Not Used	Auto	Not Used
1-13	REFLVL2	User Defined	0	0	Not Used	Not Used	Not Used	Auto	Not Used

25.1.1 Setting up EXV Level Control – User Defined

- Selecting 'User Defined' type

Sensor Input Information Screen									
Point Number	Name (1 to 10 char)	Display Type	Offset	Manual Value or NC/NO (select to change)	Display Text (select to change)	Temp. / GPM / CFM / Pwr Factor SI	Humd./PSI/ Temp. Diff. / Enthal. Diff.	Auto/Manual (Click here for all)	Circuit Index
1-12	REFLVL1	User Defined	0	0	Not Used	Not Used	Not Used	Auto	Not Used
1-13	REFLVL2	User Defined	0	0	Not Used	Not Used	Not Used	Auto	Not Used
1-14	BARLTMP1	User Logic	0	0	Not Used	Not Used	Not Used	Auto	Not Used
1-15	BARLTMP2	VirtualVane%	0	0	Not Used	Not Used	Not Used	Auto	Not Used
1-16	SPARE	VOLT5DC	0	0	Not Used	Not Used	Not Used	Auto	Not Used
2-1	SPARE2-1	0-600 VAC	0	0	Not Used	Not Used	Not Used	Auto	Not Used
		600VAC4	0	0	Not Used	Not Used	Not Used	Auto	Not Used

Under the Display Type, select User Defined

- Screen below will open:

SI Calculation Wizard

Select Display Type (Do this FIRST)

HUMID or %

	Voltage	=	Value
Point #1	1.2	=	0%
Point #2	3.7	=	100%

Calculate Cancel

1. Setting up the Level Sensor
2. Wire the Level Sensor to the designated input.
3. If available, have the Level Sensor loose and manually move the float or submerge in a bucket of liquid to 100% (standpipe full of refrigerant).
4. Record the voltage input, this would be point #2 on the SI Calculation Wizard
(Ex. Voltage = 3.7 Value = 100%)
5. Move the float to 0% (no refrigerant in the standpipe=empty)
6. Record the voltage input. This would be point #1 on the SI calculation wizard
(Ex. Voltage = 1.2 Value = 0%)

NOTE: If Level Sensor is a 4-20ma output, where at 4ma = 0% level and at 20ma = 100% level, you would put the designated input jumper on digital and the SI calculation wizard would be Setup as:

Point #1 .882 vdc = 0%

Point #2 4.41 vdc = 100%

See APP066- 4-20mA Sensor Connection to MCS-Magnum

25.1.2 Circuit Base Setup

- Point to the EXV outputs in the Circuit Base screen.

MAGNUM Circuit Base Screen

Information that relates to compressors on the circuit

Circuit# (reset button)	# of Comp RDs	Starting Compressor RO	Part Winding	Start Unload Bypass	Fast Unloader	Type of LLS	2nd LLS	Comp. Economizer (Subcooler)	Econo Control	Unloading Stages	Loader Type	HGB	HG Reheat	Liquid Injection	Oil Equalization	Mod Motor Control	Low Disc SuperHeat	External Oil Pump Control
1	3	COMP-1	No	No	No	EXV only	No	No	Slide 2	0	Unload	None	No	No	No	No	No	No
2	3	COMP-2	No	No	No	EXV only	No	No	Slide 2	0	Unload	None	No	No	No	No	No	No
3	0	Not Used	No	No	No	None	No	No	Slide 2	0	Unload	None	No	No	No	No	No	No
4	0	Not Used	No	No	No	None	No	No	Slide 2	0	Unload	None	No	No	No	No	No	No
5	0	Not Used	No	No	No	None	No	No	Slide 2	0	Unload	None	No	No	No	No	No	No
6	0	Not Used	No	No	No	None	No	No	Slide 2	0	Unload	None	No	No	No	No	No	No
7	0	Not Used	No	No	No	None	No	No	Slide 2	0	Unload	None	No	No	No	No	No	No
8	0	Not Used	No	No	No	None	No	No	Slide 2	0	Unload	None	No	No	No	No	No	No

Select Output and Sensor Inputs per circuit

Circuit # (reset button)	Alarm Relay	Comp Proof	Compr Speed(%) or Modulate Hot Gas AP	Compressor Speed Fault	Slide Closed Indicator	Pump Down	Evaporator EXV Output	Flow	Pump/Valve Proof	Circuit Pump/Valve	IGV Open %	Reheat Type	Reheat AD	Reheat RO	Amount of RD's	Reh Fat
1	Not Used	Not Used	Not Used	Not Used	Not Used	PUMPDW	EEV-1	WFS+FT	Not Used	Not Used	Not Used	None	Not Used	Not Used	0	Not Us
2	Not Used	Not Used	Not Used	Not Used	Not Used	PUMPDW	EEV-2	WFS+AFT	Not Used	Not Used	Not Used	None	Not Used	Not Used	0	Not Us
3	Not Used	Not Used	Not Used	Not Used	Not Used	Not Used	Not Used	WATER IN	Not Used	Not Used	Not Used	None	Not Used	Not Used	0	Not Us

- Point to the Refrigerant Level inputs in the Circuit SI screen.

MAGNUM Circuit SI Screen

Circuit # (reset button)	Oil Seal Temp	Pre Oil Filter	Oil Float	Leaving Temp	Refrigerant Temp	Refrig Level	Refrig. Leak Sensor	Vane Position	Evap Suct Temp	Eva
1	Not Used	Not Used	OILLVL1	Not Used	BARLTMP1	REFLVL1	Not Used	Not Used	Not Used	Not
2	Not Used	Not Used	OILLVL2	Not Used	BARLTMP2	REFLVL2	Not Used	Not Used	Not Used	Not
3	Not Used	Not Used	Not Used	Not Used	Not Used	Not Used	Not Used	Not Used	Not Used	Not

- Make sure the Discharge Pressure and Discharge Temperature are pointing to correct sensors for the calculation of discharge superheat.

MAGNUM Circuit SI Screen

Circuit # (reset button)	Suction Pressure	Discharge Pressure	Suction Temperature	Discharge Temperature	Oil Pressure	Oil Temp	Motor Temp	Oil Flow Switch	Liquid Temp	L Pre
1	SUCPRES1	DISPRES1	SUCTEMP1	DISTEMP1	Not Used	WIND.TEMP	MP+OL1	Not Used	Not Used	Not U
2	SUCPRES2	DISPRES2	SUCTEMP2	DISTEMP2	Not Used	WIND.TEMP	MP+OL2	Not Used	Not Used	Not U
3	Not Used	Not Used	Not Used	Not Used	Not Used	Not Used	Not Used	Not Used	Not Used	Not U

25.1.3 Setup using EXV CONTROL WIZARD

- Select the EXV Control button and set up for level control with the desired EXV control method.

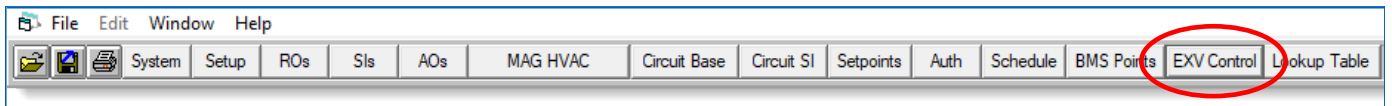

Heat Exchanger Type
Flooded Barrel

EXV Control Wizard

Control Parameter

- Suction Superheat
- Discharge Superheat
- Evaporator Level
- Condenser Level
- Approach

Heat Exchanger Type

- None
- DX Coil
- Plate HX
- DX Barrel
- Flooded Barrel

Control Method

- Normal (Original)
- P&ID
- P&ID
- PID

Target Modifier

- Low Discharge Superheat
- Oversized Condenser/High Ambient
- Maximum Operating Pressure(MOP)
- Minimum Differential Pressure(MDP)
- Target Reset
- Low Suction
- Low/High Level
- Level->CAP

Set Default Values?
Firmware Version 17.56 or Higher Required

Control Parameter
Select Evaporator Level or Condenser Level

Control Method
PID

Set Default Values
Click MCS DEFAULTS

- The following setpoints will be setup:

Setpoint Information Screen																				
#	Name	Value	Min	Max	Adjust Value	Time (SEC)	Max Time Allowed (SEC)	Lockout Delay (HRS)	Safety Down Time(MIN)	Active or Non-Active	Select Value: # decimals & print char	Level Of Auth. To Display	Type of Setpoint	Comments	SEC to Ignore Safety	Window to Ext. Safety Time(SEC)	Safety Time Extension (SEC)	High Zone	Low Zone	Setback
9	EvpLevelTarg	40	25	70	1	6	9	0	0	Active	... HUMD or %	Service L1	Target					0.1	1	0
10	Ki-IntegMult	0.13	0	3	0.01	0	0	0	0	Active	... DEC2NOCH	Service L1	Target					1	-1	0.1
11	EXV LD/UNLD%	0	0	0.5	0.1	0	0	0	0	Non-Active	... HUMD or %	Service L1	Time							
12	Kp-PropMult	0.15	0	3	0.01	0	0	0	0	Active	... DEC2NOCH	Service L1	Target					0	0	0.2
13	Kd-DerivMult	0.03	0	3	0.01	0	0	0	0	Active	... DEC2NOCH	Service L1	Target					0.6	-0.6	0.05
14	Ka-AccelMult	0.05	0	3	0.01	0	0	0	0	Active	... DEC2NOCH	Service L1	Target					0	0	0
15	ExvMinValve%	5	2	25	1	2	10	0	0	Active	... HUMD or %	Service L1	Setpoint							
16	ExvMaxValve%	100	50	100	1	0	0	0	0	Active	... HUMD or %	Service L1	Target					0	0	10
17	LO Suc sprht	1	-20	4	0.1	120	900	2	10	Non-Active	... TEMP	Service L1	Lockout		15	300	60			
18	LOW PSI DELY	1	1	30	1	3	60	0	0	Non-Active	... SECONDS	Service L1	Time							
19	ExvKiDelay	90	1	120	1	0	0	0	0	Active	... SECONDS	Service L1	Setpoint							
20	ExvStartup	30	5	45	1	5	10	0	0	Active	... SECONDS	Service L1	Time							

- NOTE: If more than one circuit is available and you want to control two independent circuit target levels, make setpoint#9 'Non-Active' in the setpoint screen.
- Make the used FLA setpoints#171-190 a 'target' type and set the level target up in the setback field.

Setpoint Information Screen																				
#	Name	Value	Min	Max	Adjust Value	Time (SEC)	Max Time Allowed (SEC)	Lockout Delay (HRS)	Safety Down Time(MIN)	Active or Non-Active	Select Value: # decimals & print char	Level Of Auth. To Display	Type of Setpoint	Comments	SEC to Ignore Safety	Window to Ext. Safety Time(SEC)	Safety Time Extension (SEC)	High Zone	Low Zone	Setback
171	FLA COMP#1	292	200	300	1	1	1	0	0	Active	... AMPS/CT	Factory L1	Target					0	0	42
172	FLA COMP#2	292	200	300	1	1	1	0	0	Active	... AMPS/CT	Factory L1	Target					0	0	34

25.1.4 Low Discharge Superheat EXV Target Adjust Logic

- Requires Firmware Version: MCS-MAGNUM Firmware - 17.61-D or later

Below are three enables for the low discharge EXV target adjustment:



7. Comp has been running for 5 minutes, or
8. Discharge temperature is greater than 130F (or 54.5C), or
9. EXV control is setup for PID Evap, PID Cond, Old Evap Level or Old Cond Level control.

- Make setpoint #110 (LoDisSHExvAd) active if you want to dynamically change the EXV target based on Low Discharge Superheat.

Setpoint Information Screen																				
#	Name	Value	Min	Max	Adjust Value	Time (SEC)	Max Time Allowed (SEC)	Lockout Delay (HRS)	Safety Down Time(MIN)	Active or Non-Active	Select Value: # decimals & print char	Level Of Auth. To Display	Type of Setpoint	Comments	SEC to Ignore Safety	Window to Ext. Safety Time(SEC)	Safety Time Extension (SEC)	High Zone	Low Zone	Setback
109	HiRefLevel	95	50	100	1	120	120	2	10	Active	... HUMD or %	Factory L1	Lockout		600	300	60			
110	LoDisSHExvAd	0.5	0.1	5	0.1	90	300	0	0	Active	... HUMD or %	Factory L1	Target					45	10	30
111	FREEZE	38	36	40	1	3	10	0	0	Active	... TEMP	Factory L1	Lockout		0	0	0			

25.1.4.1. The Low Discharge Superheat logic:

- If Setpoint #110 (#164 for REFR) is setup as a "TARGET" type setpoint the following logic occurs (New Logic):

1. If discharge superheat <= setpoint #110 (#164) low zone value and the low discharge superheat adjusted amount is less than the max adjust limit setpoint #110 setback value and the Time (SEC) value has elapsed, then:
 - a. If Evap Level control, setpoint #110 (#164) value field is subtracted from the EXV Target and this value becomes the new EXV target. The value in the Time (SEC) field will count down again and

another adjustment will be made until the max adjust is reached (setpoint #110 setback value) or the discharge superheat goes above setpoint #110 (#164) low zone value.

- b. For Cond Level control method, setpoint #110 (#164) value field is added to the EXV Target and this value becomes the new EXV Target. The value in the Time (SEC) field will count down again and another adjustment will be made until the max adjust is reached (setpoint #110 setback value) or the discharge superheat goes above setpoint #110 (#164) low zone value.
- Else if discharge superheat \geq setpoint #110 (#164) high zone value and the low discharge superheat adjusted amount is greater than 0 and the Time (SEC) value has elapsed, then:
 - a. If Evap Level control, setpoint #110 (#164) value field is added to the EXV Target and this value becomes the new EXV Target. The value in the Time (SEC) field will count down again and another adjustment will be made until the min adjust is reached (0) or the discharge superheat goes below setpoint #110 (#164) high zone value.

NOTE: The EXV Target adjusted value will not go above the original setpoint Target value.

- b. For Cond Level control method, setpoint #110 (#164) value field is subtracted from the EXV Target and this value becomes the new EXV Target. The value in the Time (SEC) field will count down again and another adjustment will be made until the min adjust is reached (0) or the discharge superheat goes below setpoint #110 (#164) high zone value.

NOTE: The EXV Target adjusted value will not go below the original setpoint Target value.

- Else If Setpoint #110 (#164) is not a "TARGET" type setpoint the following logic occurs (Old Logic):
2. If discharge superheat is $<$ Low discharge superheat safety setpoint #84 value, then:
 - a. If Evap Level or Cond Level and not level target by compressor circuit, then set EXV target to setpoint #110 value.
 - b. Else If Evap Level or Cond Level and EXV target is by compressor circuit, then subtract setpoint #110 value from the current EXV target.

Chapter - 26. Analog Output Control using PID

Required to have the software below or later version
 Config version 18.01T
 Connect version 18.31.15
 Firmware HVAC 17.62R2

PID control will turn an analog output into a stand alone PID controlled output. This output will have a controlling sensor that modulates the AO to a maintain target. This logic will run all the time.

Analog Output Information Screen			
Point Number	Name	Control Type	Invert
▶ 4-4 ...	ExvTpCtrl1	PID CTRL	NO
5-1 ...	ExvTpCtrl2	Standard	NO
5-2 ...	ExvTpCtrl3	PID CTRL	NO
5-3 ...	SPARE5-3	Linear CTRL	NO
5-4 ...	SPARE5-4	Modbus	NO
6-1 ...	SPARE6-1	Digital Scroll	NO
6-2 ...	SPARE6-2	2-10vdc	NO
		Linear/Modbus	NO

ExvTpCtrl1 (0% to 100%)

If Relay- Fan1CmpsOf is Off, then Output = 0

Else

Control Sensor		Control Target	
Point	Value	Point	Value
SI	SupplyTmp1	Setpoint Val	AHU1TrgtTmp

AO = 20 **To** 100

Proportional (Kp)
(-327.68 to 327.67)
Mult. 0.1

Integral (Ki)
(-327.68 to 327.67) (0 to 3200)
Mult. 0.7 Delay 60

Derivative (Kd)
(-327.68 to 327.67) (2 to 60)
Mult. 0.15 Interval 6

Adjustment Limits
Min Adj -5 Max Adj 5

OK

Cancel

NOTE

If AO is modulating the wrong direction, simply make all three multipliers negative values to reverse the direction the AO modulates and vice versa.

If Relay-

If a relay is used and is OFF then associated AO will be set to the defined value and not modulate. If 'not used' the logic is ignored.

Control Sensor

AO or SI point to be used as the controlling sensor for the AO.

Control Target

SI, AO, or Setpoint used as the target the AO will try to maintain.

AO

Min to Max value the AO can modulate between.

Proportional(Kp)

Multiplier for Kp adjustments.

Integral(Ki)

Multiplier and delay between Ki Adjustments

Derivative(Kd)

Multiplier and time in seconds interval to calculate Kd.

Adjustment Limits

Min and Max adjustments allowed to the AO per adjustment, both negative and positive.

Under the Analog Outputs window in the MCS Connect software. You'll find an AO PID tab that will show all of the PID CONTROL AOs and all of the calculated adjustments being made to those Analog Outputs. Here you will be able to see all three adjustments being made to the PID. This will assist you in any fine tuning required for the given analog output.

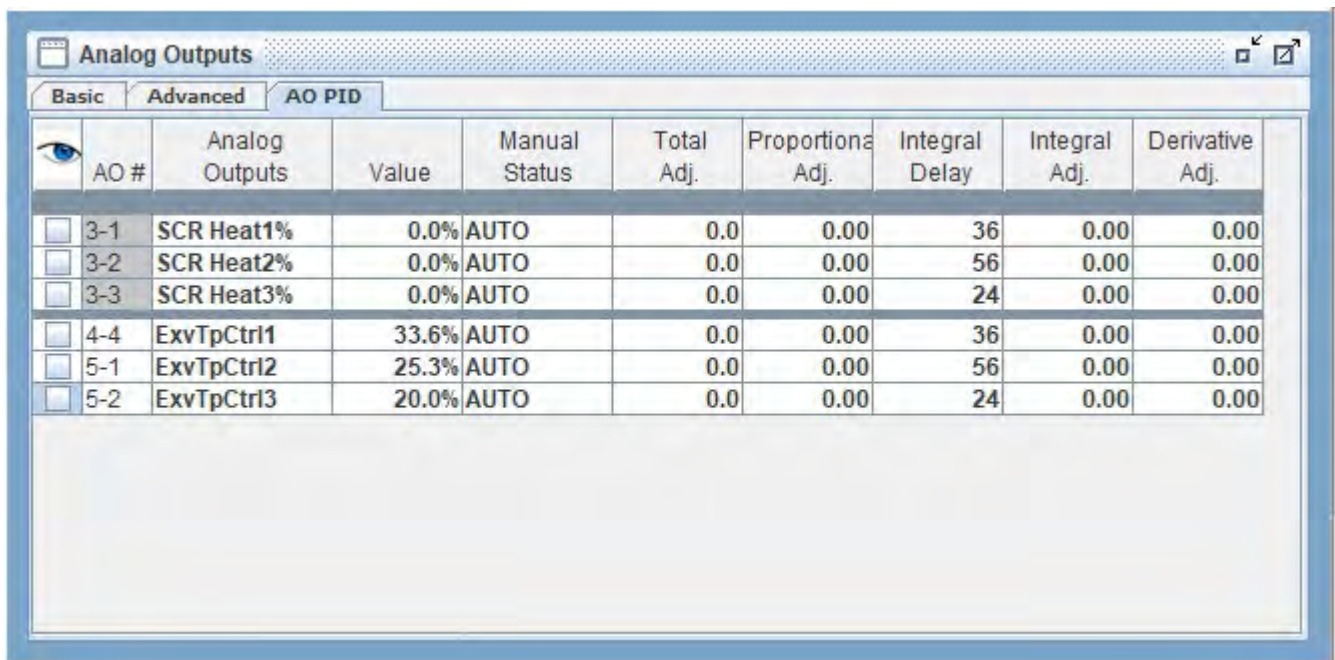

AO #	Analog Outputs	Value	Manual Status	Total Adj.	Proportional Adj.	Integral Delay	Integral Adj.	Derivative Adj.
3-1	SCR Heat1%	0.0%	AUTO	0.0	0.00	36	0.00	0.00
3-2	SCR Heat2%	0.0%	AUTO	0.0	0.00	56	0.00	0.00
3-3	SCR Heat3%	0.0%	AUTO	0.0	0.00	24	0.00	0.00
4-4	ExvTpCtrl1	33.6%	AUTO	0.0	0.00	36	0.00	0.00
5-1	ExvTpCtrl2	25.3%	AUTO	0.0	0.00	56	0.00	0.00
5-2	ExvTpCtrl3	20.0%	AUTO	0.0	0.00	24	0.00	0.00

Chapter - 27. Hardware & Software support information

Refer to MCS web site at mcscontrols.com.

27.1. OEM Factory Checkout Procedure

Then select the "Support" button and then select "Installation, Testing & Unit Commissioning".

27.2. Hardware Trouble Shooting

Then select the "Support" button and then select "Hardware Troubleshooting".

27.3. The MCS Trouble Shooting Quick Reference Sheet

The following is a quick summary

PROBLEM	POTENTIAL SOLUTION
No Sensor + 5 vdc	Indicates a possible shorted input sensor Remove all sensor + 5 vdc wires. Wait about 30 to 60 seconds. If + 5 vdc returns, replace one sensor wire at a time until the + 5 vdc is lost again. This will be the shorted sensor.
A sensor input reads -99.9	This indicates an open sensor input signal or 5 VDC problem. Check sensor wiring for missing wire or poor connection. Check sensor for bad sensor. Check + 5 vdc on sensor input to ground. If less than 5 VDC is on the sensor 5 VDC terminal block, the problem is with probably a shorted sensor. (A poly fuse protects the board) Remove all sensor input terminals. Wait about 1 min. or until 5 VDC restored at sensor input. Connect terminals 1 at time until short reappears & fix bad sensor.
A sensor input reads +999.9	This indicates a shorted sensor input signal. Check sensor wiring for +5VDC shorted to signal etc. Check sensor for bad sensor.
A pressure sensor is reading more than 1 psi off (The temperature & humidity sensors do not require calibration.)	This indicates the transducer sensor input needs to be calibrated via the offset capability in the software. (Transducers by design need to be calibrated based on construction and altitude.) You need to have a valid Auth code to change sensor offsets You must use the Windows based software package 'PConn' See PConn Interactive section for instructions. ('Change SI Status, Manual Value and / or offset.)
Invalid reading on one sensor input.	This indicates an input problem with 1 sensor. Verify jumper settings correct for that SI.
'MCS CONTROLLER INITIALIZATION' on LCD display.	Indicates Micro in constant reset. Check incoming power > 105 VAC or 22 VAC
Top row of LCD display all bars & 2nd row blank.	Indicates software chip problem possible. Possible U11 software version incorrect or chip bad. Possible U13 GAL chip incorrect or chip bad. Possible bad connection or cable between LCD and MCS8

PROBLEM	POTENTIAL SOLUTION
LCD blank.	Indicates bad connection. Connector J2 on MCS not on or offset on connector. Resistor adjustment VR1 out of adjustment.
Lost I/O	Indicates communications problem. Verify RS485 LED blinking. Verify termination jumper J6 only on at MCS-8 & last I/O. Verify MCS-8 & I/O address's set correctly. Verify wiring from MCS-8 to each I/O correct. Check fuses/120 VAC on I/O units
Changes to MCS not being made from the unit's keypad.	This indicates inability to write to chip U10. Verify 'EEP WRITE ENABLE' jumper W6 is on. Not authorized
MCS-PConnect – cannot make changes	This indicates you are not at a proper authorization level. Follow steps below for proper authorization From either the SYSTEM INFO or STATUS screen, under PConn, click on the 'AUTH' button on the lower right of your LCD display. Follow prompts and enter a valid 4-digit authorization number. The authorization level is displayed at the top of the display and is reflected via the color of the AUTH button. RED = view only YELLOW = service level BLUE = Supervisor level Green = Factory level
Invalid authorization	This indicates an invalid auth number. Follow steps below for proper authorization Press SERVICE DIAGNOSTICS key until the authorization option appears Press the ENTER key From the "Display Status" press keys corresponding to your authorization number. Press ENTER
SI from AMPS board 10 A low.	This indicates a problem with this SI only. Jumper setting on this SI in wrong position. Incorrect sensor type used.
INVALID CONFIG VER	Indicates layout of CFG wrong. CFG layout for different version than software chip U11.
INVALID CONFIG TYPE	Indicates U10 CFG incompatible with U11 software. Example U10 CFG for home while U11 for chiller.
INVALID CONFIG	Indicates Checksum invalid Reload CFG
Sensor input believed invalid (Under Sensor Diagnostic Sub Menu)	Verify Berg jumpers using Quick Reference Sheets Check board version number Check wiring of sensor

PROBLEM	POTENTIAL SOLUTION
<p>Communications to MCS-485-GATEWAY from MCS-Connect not working.</p>	<p>Verify red LED on the gate way is blinking. This indicates that the MCS-Connect program is talking to the gateway. Verify that the two wire shielded cable is properly wired from the RS-485 connector to the gateway. Verify red LED (Located just to he left of the RS-485 connector on the MCS-8 board is blinking. This indicates that the MCS-8 is responding to the gateway. If both of these LED are blinking, check the address of the MCS-8 and any other MCS-8s that are on the network. Each must have a unique address. This address can be changed from the MCS-8. Proper authorization is required. Enter the UNIT INFORMATION screen by depressing the SERVICE DIAGNOSTIC key and scrolling to this item. Depress the ENTER key and scroll to the NETWORK ADDRESS screen. Change address if needed. Verify + 12 vdc to MCS-485-GATEWAY</p>
<p>INVALID CONFIG</p>	<p>Indicates Checksum invalid Either set to factory defaults on reset settings.</p>

--- NOTE ---

ALL SENSOR INPUTS SHOULD BE SHIELDED CABLE WITH SHIELD TIED TO GROUND ON MCS-8 SENSOR INPUT GROUND TERMINAL

Chapter - 28. MODBUS RTU

Modbus RTU is supported directly by the MCS-Magnum using the RS485 port.

Please note this is the same port you plug into the RS232, so if using Modbus RTU you cannot plug you laptop into RS232 port on the older keypad.

Please note the RS485 follows industry standard, two wire twisted pair in shielded cable.

28.1. Setup the Modbus from MCS-Config's Magnum Setup Screen(see below):

The screenshot displays the 'MAGNUM Setup Screen' with various configuration options. The 'MAG RTU' tab is selected. The 'RS485 Communication' section is highlighted with a red box, showing the following settings:

- RTU Protocol Address: 1
- Protocol Type: MODBUS RTU
- Baud Rate: 9600
- Slave Address: 1
- Disable Alarm Grid Pop-Up In MCS-Connect?: Yes No

Other visible settings include:

- Display Units: Deg F / PSI
- Default LCD Display: UNIT STATUS
- Default Display Point: (empty)
- Max Lockout Resets per Day: 6
- Auth Level Bypass: Supervisor Level
- Lockout Reset SI: Not Used
- History Sample Rate (Seconds): 90
- Activate Keypad Cursor Quick Move Feature?: Yes No
- Generate Alarm for Network Time Synchronization: Yes No
- Generate Alarm When Configuration is Updated: Yes No
- Display Alarm Character(a) On Keypad LCD Screen: Yes No
- Total Number of RO's: 30
- Total Number of AO's: 17
- Total Number of SI's: 81
- Number of RO Boards: 1
- Number of SI16 boards: 3
- Type of I/O Boards: RO-8 & SI-16 & MCS I/O RO-10 & SI-16-A04
- MCS-Thermostat: Yes No
- Factory Startup: Enable This Feature? Yes No; Feature Is Active? (Password Entered) Yes No
- Run Hour Lockout: Enable This Feature? Yes No; Feature Is Active? (Password Entered) Yes No
- Daylight Savings Time: Daylight Savings Time Active Yes No; Daylight Savings Time DOW: Sunday; Daylight Savings Time Hour: 2
- Spring Forward Month: March; Spring Forward Begin Date: 8; Spring Forward End Date: 14; Fall Back Month: November; Fall Back Begin Date: 1; Fall Back End Date: 7
- Ethernet Communication: Static IP Dynamic IP; IP Address: 192.168.10.253; Subnet Mask: 255.255.255.0; Default Gateway: 192.168.10.1; MCS IP Port: 5001; BACnet Device ID: 181 02; BACnet Port: 47 808; Extended BACnet Device ID: (empty); Hardcoded Port Numbers: Modbus Port = 502; Website Port = 80; BACnet MV Values Start At: Zero One
- System Graphic Information: Name of Graphic .html file : C://MCS/Graphics/ RL134/SystemOverview.html

28.2. From MCS-Connect's Service Window RS485 tab(see below):

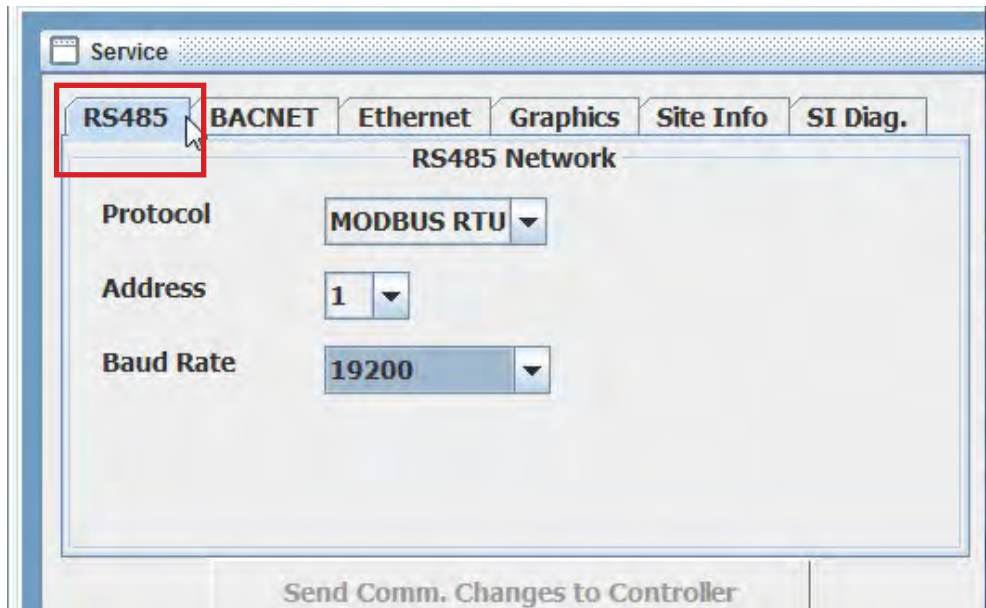

28.3. From MCS-Magnum LCD/Keypad(see below):

Service Tools (RS485 Network)



28.4. In MCS-CONFIG you can see & print a list of the Modbus Registers (see below):

BMS Communication Protocols					
					CREATE MCS-BMS-GATEWAY CSV FILES
<input checked="" type="radio"/> SI Points <input type="radio"/> RO Points <input type="radio"/> RO Run Hours <input type="radio"/> RO Cycles <input type="radio"/> AO Points <input type="radio"/> Setpoint Values <input type="radio"/> Unit Control Info <input type="radio"/> Compressor Points <input type="radio"/> Writable Points <input type="radio"/> Alarms					
Sensor Input Status					
POINT MAPPING INFO BUILT IN MCS-MAGNUM					
MCS-MAGNUM		BACNET ID		MODBUS IP & RTU	
PT	Name	Object ID	Name	Register	# Assumed Dec
M-1	ChilWtr In	AI:1	ChilWtr In	30001	1
M-2	ChilWtrOut	AI:2	ChilWtrOut	30002	1
M-3	SUCT PSI 1	AI:3	SUCT PSI 1	30003	1
M-4	DISC PSI 1	AI:4	DISC PSI 1	30004	1
M-5	OIL PSI 1	AI:5	OIL PSI 1	30005	1
M-6	AMPS 1	AI:6	AMPS 1	30006	1
M-7	SUCT TMP 1	AI:7	SUCT TMP 1	30007	1
M-8	DISC TMP 1	AI:8	DISC TMP 1	30008	1
M-9	MTR TMP 1	AI:9	MTR TMP 1	30009	1
M10	MTR FLT 1	AI:10	MTR FLT 1	30010	0
M11	OIL LVL 1	AI:11	OIL LVL 1	30011	0
M12	DISABLE 1	AI:12	DISABLE 1	30012	0
M13	CHW FLOW	AI:13	CHW FLOW	30013	0
M14	PHASELOSS	AI:14	PHASELOSS	30014	0
M15	RUN/STOP	AI:15	RUN/STOP	30015	0

The MCS-Magnum Modbus RTU setting allow you to specify the Modbus Slave address, Modbus Baud rate (4800, 9600, 19200, 38400, 57600 are supported).

The number data bit is 8, stop bit is 1 and parity is none (these parameter are **not adjustable**).

The sensors inputs are 16 bit signed values. (Read input Registers, Function code = 4)

- The analog sensor inputs values typically have 1 assumed decimal place, meaning a value of 12.3 will be transmitted as value 123. The # of decimal point depending on the sensor type define in the MCS-MAGNUM CONFIG. Most sensor types are 1 decimal place.

But take care there are a few 2 decimal and a few zero decimal place types.

The BMS point list has a column which indicates how many assumed decimal are contained in the value.

- The digital sensor inputs values will be 0 or 1, 0 = off and 1 = on.

The analog outputs are 16 bit signed values. (Read Input Registers, Function code = 4)

- The analog output have 1 assumed decimal place, meaning a value of 12.3 will be transmitted as value 123.

The relay outputs are 16 bit packed values. (Read Coil Status , Function code = 1)

- Each bit within the 16 bits can contains a relay output. A bit value of 0 = relay off, 1 = relay on.

The number of packed bit depends on the requesting Modbus message.

If only one coil is asked for, then only bit 0 will contains a relay status value and bit 1 thru 7 are do not care.

If two relays are asked for, then bit 0 and bit 1 will contains values and bit 2 thru 7 are do not care.

The setpoints are 16 bit signed values. (Read Holding Registers, Function code = 3)

- The setpoints values typically have 1 assumed decimal place, meaning a value of 12.3 will be transmitted as value 123.

The # of decimal point depending on the setpoint type defined in the MCS-MAGNUM CONFIG.

Chapter - 29. BMS Communication Protocols

The MCS-Magnum supports as standard: BACnet IP, Modbus RTU, and Modbus TCP/IP protocols.

Using the MCS-BMS-GATEWAY, the MCS-Magnum can also support Johnson N2, LonTalk and Bacnet MSTP.

Supported baud rates for Modbus RTU and Johnson N2 are 4800bps, 9600bps, 19200bps, 38400bps, and 57600bps.

29.1. MCS-Magnum to BMS Connections

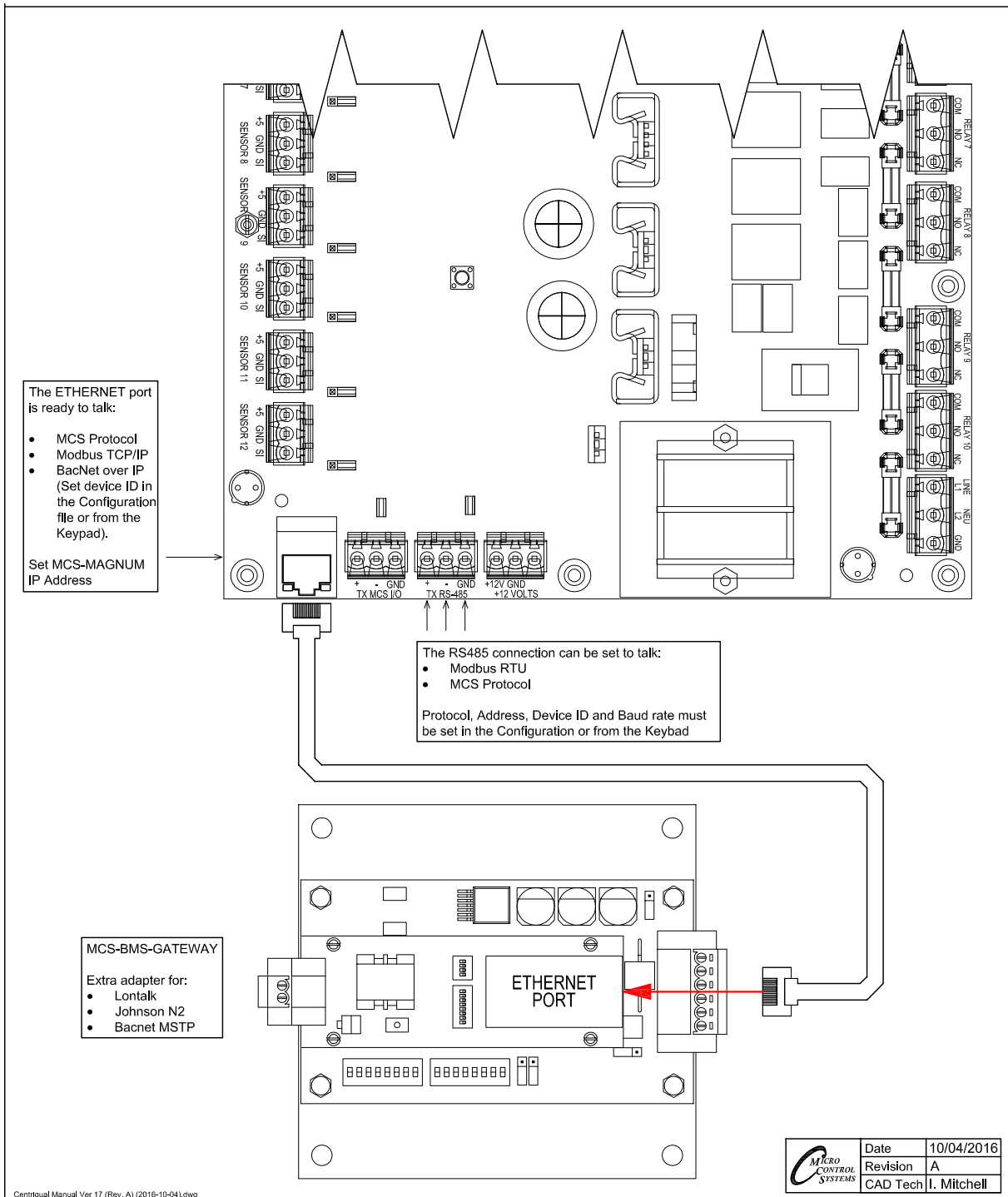

Centrigual Manual Ver 17 (Rev. A) (2016-10-04).dwg

29.2. Sensor Input Points

Sensor numbering is based upon the MCS-MAGNUM or SI16-AO4 hardware type board Notable BACnet properties available: Units

Magnum	BACnet ID	BACnet Name	Modbus Register	N2
Sensor M-1	AI: 1	Refer to Config	*30001	*AI: 1
Sensor M-2	AI: 2	Refer to Config	*30002	*AI: 2
Sensor M-3	AI: 3	Refer to Config	*30003	*AI: 3
Sensor M-4	AI: 4	Refer to Config	*30004	*AI: 4
Sensor M-5	AI: 5	Refer to Config	*30005	*AI: 5
Sensor M-6	AI: 6	Refer to Config	*30006	*AI: 6
Sensor M-7	AI: 7	Refer to Config	*30007	*AI: 7
Sensor M-8	AI: 8	Refer to Config	*30008	*AI: 8
Sensor M-9	AI: 9	Refer to Config	*30009	*AI: 9
Sensor M-10	AI:10	Refer to Config	*30010	*AI: 10
Sensor M-11	AI:11	Refer to Config	*30011	*AI: 11
Sensor M-12	AI:12	Refer to Config	*30012	*AI: 12
Sensor M-13	AI:13	Refer to Config	*30013	*AI: 13
Sensor M-14	AI:14	Refer to Config	*30014	*AI: 14
Sensor M-15	AI:15	Refer to Config	*30015	*AI: 15
Sensor M-16	AI:16	Refer to Config	*30016	*AI: 16
Sensor 1-1	AI:17	Refer to Config	*30017	*AI: 17
Sensor 1-2	AI:18	Refer to Config	*30018	*AI: 18
Sensor 1-3	AI:19	Refer to Config	*30019	*AI: 19
Sensor 1-4	AI:20	Refer to Config	*30020	*AI: 20
Sensor 1-5	AI:21	Refer to Config	*30021	*AI: 21
Sensor 1-6	AI:22	Refer to Config	*30022	*AI: 22
Sensor 1-7	AI:23	Refer to Config	*30023	*AI: 23
Sensor 1-8	AI:24	Refer to Config	*30024	*AI: 24
Sensor 1-9	AI:25	Refer to Config	*30025	*AI: 25
Sensor 1-10	AI:26	Refer to Config	*30026	*AI: 26
Sensor 1-11	AI:27	Refer to Config	*30027	*AI: 27
Sensor 1-12	AI:28	Refer to Config	*30028	*AI: 28
Sensor 1-13	AI:29	Refer to Config	*30029	*AI: 29
Sensor 1-14	AI:30	Refer to Config	*30030	*AI: 30
Sensor 1-15	AI:31	Refer to Config	*30031	*AI: 31
Sensor 1-16	AI:32	Refer to Config	*30032	*AI: 32
Sensor 2-1	AI:33	Refer to Config	*30033	*AI: 33
Sensor 2-2	AI:34	Refer to Config	*30034	*AI: 34
Sensor 2-3	AI:35	Refer to Config	*30035	*AI: 35
Sensor 2-4	AI:36	Refer to Config	*30036	*AI: 36
Sensor 2-5	AI:37	Refer to Config	*30037	*AI: 37
Sensor 2-6	AI:38	Refer to Config	*30038	*AI: 38
Sensor 2-7	AI:39	Refer to Config	*30039	*AI: 39
Sensor 2-8	AI:40	Refer to Config	*30040	*AI: 40

Magnum	BACnet ID	BACnet Name	Modbus Register	N2
Sensor 2-9	AI:41	Refer to Config	*30041	*AI: 41
Sensor 2-10	AI:42	Refer to Config	*30042	*AI: 42
Sensor 2-11	AI:43	Refer to Config	*30043	*AI: 43
Sensor 2-12	AI:44	Refer to Config	*30044	*AI: 44
Sensor 2-13	AI:45	Refer to Config	*30045	*AI: 45
Sensor 2-14	AI:46	Refer to Config	*30046	*AI: 46
Sensor 2-15	AI:47	Refer to Config	*30047	*AI: 47
Sensor 2-16	AI:48	Refer to Config	*30048	*AI: 48
Sensor 3-1	AI:49	Refer to Config	*30049	*AI:49
Sensor 3-2	AI:50	Refer to Config	*30050	*AI: 50
Sensor 3-3	AI:51	Refer to Config	*30051	*AI: 51
Sensor 3-4	AI:52	Refer to Config	*30052	*AI: 52
Sensor 3-5	AI:53	Refer to Config	*30053	*AI: 53
Sensor 3-6	AI:54	Refer to Config	*30054	*AI: 54
Sensor 3-7	AI:55	Refer to Config	*30055	*AI: 55
Sensor 3-8	AI:56	Refer to Config	*30056	*AI: 56
Sensor 3-9	AI:57	Refer to Config	*30057	*AI: 57
Sensor 3-10	AI:58	Refer to Config	*30058	*AI: 58
Sensor 3-11	AI:59	Refer to Config	*30059	*AI: 59
Sensor 3-12	AI:60	Refer to Config	*30060	*AI: 60
Sensor 3-13	AI:61	Refer to Config	*30061	*AI: 61
Sensor 3-14	AI:62	Refer to Config	*30062	*AI: 62
Sensor 3-15	AI:63	Refer to Config	*30063	*AI: 63
Sensor 3-16	AI:64	Refer to Config	*30064	*AI: 64
Sensor 4-1	AI:65	Refer to Config	*30065	*AI: 65
Sensor 4-2	AI:66	Refer to Config	*30066	*AI: 66
Sensor 4-3	AI:67	Refer to Config	*30067	*AI: 67
Sensor 4-4	AI:68	Refer to Config	*30068	*AI: 68
Sensor 4-5	AI:69	Refer to Config	*30069	*AI: 69
Sensor 4-6	AI:70	Refer to Config	*30070	*AI: 70
Sensor 4-7	AI:71	Refer to Config	*30071	*AI: 71
Sensor 4-8	AI:72	Refer to Config	*30072	*AI: 72
Sensor 4-9	AI:73	Refer to Config	*30073	*AI: 73
Sensor 4-10	AI:74	Refer to Config	*30074	*AI: 74
Sensor 4-11	AI:75	Refer to Config	*30075	*AI: 75
Sensor 4-12	AI:76	Refer to Config	*30076	*AI: 76
Sensor 4-13	AI:77	Refer to Config	*30077	*AI: 77
Sensor 4-14	AI:78	Refer to Config	*30078	*AI: 78
Sensor 4-15	AI:79	Refer to Config	*30079	*AI: 79
Sensor 4-16	AI:80	Refer to Config	*30080	*AI: 80

*- Indicates value multiplied by 10 to include one decimal place. (I.e. BMS value of 500 indicates actual value 50.0)

29.3. Relay Output Points

Relay Output points are read-only. Sensor numbering is based upon RO-10 hardware type board

Magnum	BACnet ID	BACnet Name	Modbus	N2
Relay M-1	BO: 1	Refer to Config	00001	BO: 1
Relay M-2	BO: 2	Refer to Config	00002	BO: 2
Relay M-3	BO: 3	Refer to Config	00003	BO: 3
Relay M-4	BO: 4	Refer to Config	00004	BO: 4
Relay M-5	BO: 5	Refer to Config	00005	BO: 5
Relay M-6	BO: 6	Refer to Config	00006	BO: 6
Relay M-7	BO: 7	Refer to Config	00007	BO: 7
Relay M-8	BO: 8	Refer to Config	00008	BO: 8
Relay M-9	BO: 9	Refer to Config	00009	BO: 9
Relay M-10	BO:10	Refer to Config	00010	BO: 10
Relay 1-1	BO:11	Refer to Config	00011	BO: 11
Relay 1-2	BO:12	Refer to Config	00012	BO: 12
Relay 1-3	BO:13	Refer to Config	00013	BO: 13
Relay 1-4	BO:14	Refer to Config	00014	BO: 14
Relay 1-5	BO:15	Refer to Config	00015	BO: 15
Relay 1-6	BO:16	Refer to Config	00016	BO: 16
Relay 1-7	BO:17	Refer to Config	00017	BO: 17
Relay 1-8	BO:18	Refer to Config	00018	BO: 18
Relay 1-9	BO:19	Refer to Config	00019	BO: 19
Relay 1-10	BO:20	Refer to Config	00020	BO: 20
Relay 2-1	BO:21	Refer to Config	00021	BO: 21
Relay 2-2	BO:22	Refer to Config	00022	BO: 22
Relay 2-3	BO:23	Refer to Config	00023	BO: 23
Relay 2-4	BO:24	Refer to Config	00024	BO: 24
Relay 2-5	BO:25	Refer to Config	00025	BO: 25
Relay 2-6	BO:26	Refer to Config	00026	BO: 26
Relay 2-7	BO:27	Refer to Config	00027	BO: 27
Relay 2-8	BO:28	Refer to Config	00028	BO: 28
Relay 2-9	BO:29	Refer to Config	00029	BO: 29
Relay 2-10	BO:30	Refer to Config	00030	BO: 30
Relay 3-1	BO:31	Refer to Config	00031	BO: 31
Relay 3-2	BO:32	Refer to Config	00032	BO: 32
Relay 3-3	BO:33	Refer to Config	00033	BO: 33
Relay 3-4	BO:34	Refer to Config	00034	BO: 34
Relay 3-5	BO:35	Refer to Config	00035	BO: 35
Relay 3-6	BO:36	Refer to Config	00036	BO: 36
Relay 3-7	BO:37	Refer to Config	00037	BO: 37
Relay 3-8	BO:38	Refer to Config	00038	BO: 38
Relay 3-9	BO:39	Refer to Config	00039	BO: 39
Relay 3-10	BO:40	Refer to Config	00040	BO: 40

Magnum	BACnet ID	BACnet Name	Modbus	N2
Relay 4-1	BO:41	Refer to Config	00041	BO: 41
Relay 4-2	BO:42	Refer to Config	00042	BO: 42
Relay 4-3	BO:43	Refer to Config	00043	BO: 43
Relay 4-4	BO:44	Refer to Config	00044	BO: 44
Relay 4-5	BO:45	Refer to Config	00045	BO: 45
Relay 4-6	BO:46	Refer to Config	00046	BO: 46
Relay 4-7	BO:47	Refer to Config	00047	BO: 47
Relay 4-8	BO:48	Refer to Config	00048	BO: 48
Relay 4-9	BO:49	Refer to Config	00049	BO: 49
Relay 4-10	BO:50	Refer to Config	00050	BO: 50
Relay 5-1	BO:51	Refer to Config	00051	BO: 51
Relay 5-2	BO:52	Refer to Config	00052	BO: 52
Relay 5-3	BO:53	Refer to Config	00053	BO: 53
Relay 5-4	BO:54	Refer to Config	00054	BO: 54
Relay 5-5	BO:55	Refer to Config	00055	BO: 55
Relay 5-6	BO:56	Refer to Config	00056	BO: 56
Relay 5-7	BO:57	Refer to Config	00057	BO: 57
Relay 5-8	BO:58	Refer to Config	00058	BO: 58
Relay 5-9	BO:59	Refer to Config	00059	BO: 59
Relay 5-10	BO:60	Refer to Config	00060	BO: 60
Relay 6-1	BO:61	Refer to Config	00061	BO: 61
Relay 6-2	BO:62	Refer to Config	00062	BO: 62
Relay 6-3	BO:63	Refer to Config	00063	BO: 63
Relay 6-4	BO:64	Refer to Config	00064	BO: 64
Relay 6-5	BO:65	Refer to Config	00065	BO: 65
Relay 6-6	BO:66	Refer to Config	00066	BO: 66
Relay 6-7	BO:67	Refer to Config	00067	BO: 67
Relay 6-8	BO:68	Refer to Config	00068	BO: 68
Relay 6-9	BO:69	Refer to Config	00069	BO: 69
Relay 6-10	BO:70	Refer to Config	00760	BO: 70
Relay 7-1	BO:71	Refer to Config	00071	BO: 71
Relay 7-2	BO:72	Refer to Config	00072	BO: 72
Relay 7-3	BO:73	Refer to Config	00073	BO: 73
Relay 7-4	BO:74	Refer to Config	00074	BO: 74
Relay 7-5	BO:75	Refer to Config	00075	BO: 75
Relay 7-6	BO:76	Refer to Config	00076	BO: 76
Relay 7-7	BO:77	Refer to Config	00077	BO: 77
Relay 7-8	BO:78	Refer to Config	00078	BO: 78
Relay 7-9	BO:79	Refer to Config	00079	BO: 79
Relay 7-10	BO:80	Refer to Config	00070	BO: 80

*- Indicates value multiplied by 10 to include one decimal place. (I.e. BMS value of 500 indicates actual value 50.0)

Analog Output Points Analog Output points are read-only. Sensor numbering is based upon SI16-AO4 hardware type board. Notable BACnet properties available: Units

Magnum	BACnet ID	BACnet Name	Modbus Register	N2
Analog Out M-1	AO:1	Refer to Config	*30201	*AO: 1
Analog Out M-2	AO:2	Refer to Config	*30202	*AO: 2
Analog Out M-3	AO:3	Refer to Config	*30203	*AO: 3
Analog Out M-4	AO:4	Refer to Config	*30204	*AO: 4
Analog Out 1-1	AO:5	Refer to Config	*30205	*AO: 5
Analog Out 1-2	AO:6	Refer to Config	*30206	*AO: 6
Analog Out 1-3	AO:7	Refer to Config	*30207	*AO: 7
Analog Out 1-4	AO:7	Refer to Config	*30208	*AO: 8
Analog Out 2-1	AO:8	Refer to Config	*30209	*AO: 9
Analog Out 2-2	AO:10	Refer to Config	*30210	*AO: 10
Analog Out 2-3	AO:11	Refer to Config	*30211	*AO: 11
Analog Out 2-4	AO:12	Refer to Config	*30212	*AO: 12
Analog Out 3-1	AO:13	Refer to Config	*30213	*AO: 13
Analog Out 3-2	AO:14	Refer to Config	*30214	*AO: 14
Analog Out 3-3	AO:15	Refer to Config	*30215	*AO: 15
Analog Out 3-4	AO:16	Refer to Config	*30216	*AO: 16
Analog Out 4-1	AO:17	Refer to Config	*30217	*AO: 17
Analog Out 4-2	AO:18	Refer to Config	*30218	*AO: 18
Analog Out 4-3	AO:19	Refer to Config	*30219	*AO: 19
Analog Out 4-4	AO:20	Refer to Config	*30220	*AO: 20

*- Indicates value multiplied by 10 to include one decimal place. (I.e. BMS value of 500 indicates actual value 50.0)

29.4. Setpoints

Setpoints are read-only. Notable BACnet properties available: Units

Magnum	BACnet ID	BACnet Name	Modbus	N2
Setpoint #1	AV:0	STP# 1-<Setpoint name>	40301	ADF:1
Setpoint #21	AV:88	STP# 21-<Setpoint name>	40321	ADF:89
Setpoint #163	AV:230	STP# 163-<Setpoint name>	40463	ADF:231

*- Indicates value multiplied by 10 to include one decimal place. (I.e. BMS value of 500 indicates actual value 50.0)

29.5. Chiller/Compressor States

State values are read-only. Notable BACnet properties available: Number of States, State-Text (Contains character text of current state)

Magnum	BACnet ID	BACnet Name	Modbus Register	N2
Chiller Unit State	MV:0	CHILLER STATE	30306	BYT:1
Compressor #1 State	MV:1	COMPRESSOR #1 STATE	30307	BYT:2
Compressor #2 State	MV:2	COMPRESSOR #2 STATE	30308	BYT:3
Compressor #3 State	MV:3	COMPRESSOR #3 STATE	30309	BYT:4
Compressor #4 State	MV:4	COMPRESSOR #4 STATE	30310	BYT:5
Compressor #5 State	MV:5	COMPRESSOR #5 STATE	30311	BYT:6
Compressor #6 State	MV:6	COMPRESSOR #6 STATE	30312	BYT:7

Magnum	BACnet ID	BACnet Name	Modbus Register	N2
Compressor #7 State	MV:7	COMPRESSOR #7 STATE	30313	BYT:8
Compressor #8 State	MV:8	COMPRESSOR #8 STATE	30314	BYT:9
Compressor #9 State	MV:130	COMPRESSOR #9 STATE	30560	BYT:131
Compressor #10 State	MV:131	COMPRESSOR #10 STATE	30561	BYT:132
Compressor #11 State	MV:132	COMPRESSOR #11 STATE	30562	BYT:133
Compressor #12 State	MV:133	COMPRESSOR #12 STATE	30563	BYT:134
Compressor #13 State	MV:134	COMPRESSOR #13 STATE	30564	BYT:135
Compressor #14 State	MV:135	COMPRESSOR #14 STATE	30565	BYT:136
Compressor #15 State	MV:136	COMPRESSOR #15 STATE	30566	BYT:137
Compressor #16 State	MV:137	COMPRESSOR #16 STATE	30567	BYT:138
Compressor #17 State	MV:138	COMPRESSOR #17 STATE	30568	BYT:139
Compressor #18 State	MV:139	COMPRESSOR #18 STATE	30569	BYT:140
Compressor #19 State	MV:140	COMPRESSOR #19 STATE	30570	BYT:141
Compressor #20 State	MV:141	COMPRESSOR #20 STATE	30571	BYT:142

29.6. Other Points

These points are read-only.

Magnum	BACnet ID	BACnet Name	Modbus	N2
Wanted FLA%	AV:3	Wanted FLA%	30318	ADF:4
Steps Wanted	AV:4	Steps Wanted On	30315	ADF:5
Steps On	AV:5	Steps On	30316	ADF:6
Step Delay	AV:6	Step Delay	30317	ADF:7
Compressor #1 FLA%	AV:7	C1_FL A%	*30319	*ADF:8
Compressor #1 Sat Suction	AV:10	C1_Sat Suct	*30327	*ADF:11
Compressor #1 Sat Disch	AV:11	C1_Sat Disch	*30329	*ADF:12
Compressor #1 Disch SH	AV:12	C1_Disch SH	*30330	*ADF:13
Compressor #1 Suct SH	AV:13	C1_Suct SH	*30328	*ADF:14
Compressor #1 Oil Pres Diff	AV:63	C1_Oil Pres Diff	*30375	*ADF:64
Compressor #2 FLA%	AV:14	C2_FL A%	*30320	*ADF:15
Compressor #2 Sat Suction	AV:17	C2_Sat Suct	*30331	*ADF:18
Compressor #2 Sat Disch	AV:18	C2_Sat Disch	*30333	*ADF:19
Compressor #2 Disch SH	AV:19	C2_Disch SH	*30334	*ADF:20
Compressor #2 Suct SH	AV:20	C2_Suct SH	*30332	*ADF:21
Compressor #2 Oil Pres Diff	AV:64	C2_Oil Pres Diff	*30376	*ADF:65
Compressor #3 FLA%	AV:21	C3_FL A%	*30321	*ADF:22
Compressor #3 Sat Suction	AV:24	C3_Sat Suct	*30335	*ADF:25
Compressor #3 Sat Disch	AV:25	C3_Sat Disch	*30337	*ADF:26
Compressor #3 Disch SH	AV:26	C3_Disch SH	*30338	*ADF:27
Compressor #3 Suct SH	AV:27	C3_Suct SH	*30336	*ADF:28
Compressor #3 Oil Pres Diff	AV:65	C3_Oil Pres Diff	*30377	*ADF:66
Compressor #4 FLA%	AV:28	C4_FL A%	*30322	*ADF:29
Compressor #4 Sat Suction	AV:31	C4_Sat Suct	*30339	*ADF:32
Compressor #4 Sat Disch	AV:32	C4_Sat Disch	*30341	*ADF:33
Compressor #4 Disch SH	AV:33	C4_Disch SH	*30342	*ADF:34
Compressor #4 Suct SH	AV:34	C4_Suct SH	*30340	*ADF:35
Compressor #4 Oil Pres Diff	AV:66	C4_Oil Pres Diff	*30378	*ADF:67
Compressor #5 FLA%	AV:35	C5_FL A%	*30323	*ADF:36
Compressor #5 Sat Suction	AV:38	C5_Sat Suct	*30343	*ADF:39

Magnum	BACnet ID	BACnet Name	Modbus	N2
Compressor #5 Sat Disch	AV:39	C5_ Sat Disch	*30345	*ADF:40
Compressor #5 Disch SH	AV:40	C5_Disch SH	*30346	*ADF:41
Compressor #5 Suct SH	AV:41	C5_Suct SH	*30344	*ADF:42
Compressor #5 Oil Pres Diff	AV:67	C5_Oil Pres Diff	*30379	*ADF:68
Compressor #6 FLA%	AV:42	C6_FLA%	*30324	*ADF:43
Compressor #6 Sat Suction	AV:45	C6_Sat Suct	*30347	*ADF:46
Compressor #6 Sat Disch	AV:46	C6_ Sat Disch	*30349	*ADF:47
Compressor #6 Disch SH	AV:47	C6_Disch SH	*30350	*ADF:48
Compressor #6 Suct SH	AV:48	C6_Suct SH	*30348	*ADF:49
Compressor #6 Oil Pres Diff	AV:68	C6_Oil Pres Diff	*30380	*ADF:69
Compressor #7 FLA%	AV:49	C7_FLA%	*30325	*ADF:50
Compressor #7 Sat Suction	AV:52	C7_Sat Suct	*30351	*ADF:53
Compressor #7 Sat Disch	AV:53	C7_ Sat Disch	*30353	*ADF:54
Compressor #7 Disch SH	AV:54	C7_Disch SH	*30354	*ADF:55
Compressor #7 Suct SH	AV:55	C7_Suct SH	*30352	*ADF:56
Compressor #7 Oil Pres Diff	AV:69	C7_Oil Pres Diff	*30381	*ADF:70
Compressor #8 FLA%	AV:56	C8_FLA%	*30326	*ADF:57
Compressor #8 Sat Suction	AV:59	C8_Sat Suct	*30352	*ADF:53
Compressor #8 Sat Suction	AV:59	C8_Sat Suct	*30355	*ADF:60
Compressor #8 Sat Disch	AV:60	C8_ Sat Disch	*30357	*ADF:61
Compressor #8 Disch SH	AV:61	C8_Disch SH	*30358	*ADF:62
Compressor #8 Suct SH	AV:62	C8_Suct SH	*30356	*ADF:63
Compressor #8 Oil Pres Diff	AV:70	C8_Oil Pres Diff	*30382	*ADF:71
Compressor #9 FLA%	AV:440	C9_FLA%	*30572	*ADF:441
Compressor #9 Sat Suction	AV: 443	C9_Sat Suct	*30584	*ADF: 442
Compressor #9 Sat Disch	AV: 444	C9_ Sat Disch	*30586	*ADF: 443
Compressor #9 Disch SH	AV: 445	C9_Disch SH	*30587	*ADF: 444
Compressor #9 Suct SH	AV: 446	C9_Suct SH	*30585	*ADF: 445
Compressor #9 Oil Pres Diff	AV:524	C9_Oil Pres Diff	*30656	*ADF:525
Compressor #10 FLA%	AV:447	C10_FLA%	*30573	*ADF:448
Compressor #10 Sat Suction	AV: 450	C10_Sat Suct	*30588	*ADF: 451
Compressor #10 Sat Disch	AV: 451	C10_ Sat Disch	*30590	*ADF: 452
Compressor #10 Disch SH	AV: 452	C10_Disch SH	*30591	*ADF: 453
Compressor #10 Suct SH	AV: 453	C10_Suct SH	*30589	*ADF: 454
Compressor #10 Oil Pres Diff	AV:525	C10_Oil Pres Diff	*30657	*ADF:526
Compressor #11 FLA%	AV:454	C11_FLA%	*30574	*ADF:455
Compressor #11 Sat Suction	AV: 457	C11_Sat Suct	*30592	*ADF: 458
Compressor #11 Sat Disch	AV: 458	C11_ Sat Disch	*30594	*ADF: 459
Compressor #11 Disch SH	AV: 459	C11_Disch SH	*30595	*ADF: 460
Compressor #11 Suct SH	AV: 460	C11_Suct SH	*30593	*ADF: 461
Compressor #11 Oil Pres Diff	AV: 526	C11_Oil Pres Diff	*30658	*ADF: 527
Compressor #12 FLA%	AV: 461	C12_FLA%	*30575	*ADF: 462
Compressor #12 Sat Suction	AV: 464	C12_Sat Suct	*30596	*ADF: 465
Compressor #12 Sat Disch	AV: 465	C12_ Sat Disch	*30598	*ADF: 466
Compressor #12 Disch SH	AV: 466	C12_Disch SH	*30599	*ADF: 467
Compressor #12 Suct SH	AV: 467	C12_Suct SH	*30597	*ADF 468
Compressor #12 Oil Pres Diff	AV:527	C12_Oil Pres Diff	*30659	*ADF:528
Compressor #13 FLA%	AV:468	C13_FLA%	*30576	*ADF:469
Compressor #13 Sat Suction	AV: 471	C13_Sat Suct	*30600	*ADF: 470
Compressor #13 Sat Disch	AV: 472	C13_ Sat Disch	*30602	*ADF: 473
Compressor #13 Disch SH	AV: 473	C13_Disch SH	*30603	*ADF: 474
Compressor #13 Suct SH	AV: 474	C13_Suct SH	*30600	*ADF: 475

Magnum	BACnet ID	BACnet Name	Modbus	N2
Compressor #13 Oil Pres Diff	AV: 528	C13_Oil Pres Diff	*30661	*ADF: 529
Compressor #14 FLA%	AV: 475	C14_FL A%	*30577	*ADF: 476
Compressor #14 Sat Suction	AV: 478	C14_Sat Suct	*30604	*ADF: 479
Compressor #14 Sat Disch	AV: 479	C14_Sat Disch	*30606	*ADF: 480
Compressor #14 Disch SH	AV: 480	C14_Disch SH	*30607	*ADF: 481
Compressor #14 Suct SH	AV: 481	C14_Suct SH	*30605	*ADF: 482
Compressor #14 Oil Pres Diff	AV: 529	C14_Oil Pres Diff	*30661	*ADF: 530
Compressor #15 FLA%	AV: 482	C15_FL A%	*30578	*ADF: 483
Compressor #15 Sat Suction	AV: 485	C15_Sat Suct	*30608	*ADF: 486
Compressor #15 Sat Disch	AV: 486	C15_Sat Disch	*30610	*ADF: 487
Compressor #15 Disch SH	AV: 487	C15_Disch SH	*30611	*ADF: 488
Compressor #15 Suct SH	AV: 488	C15_Suct SH	*30609	*ADF: 489
Compressor #15 Oil Pres Diff	AV: 530	C15_Oil Pres Diff	*3062	*ADF: 531
Compressor #16 FLA%	AV: 489	C16_FL A%	*30579	*ADF: 490
Compressor #16 Sat Suction	AV: 492	C16_Sat Suct	*30612	*ADF: 493
Compressor #16 Sat Disch	AV: 493	C16_Sat Disch	*30614	*ADF: 494
Compressor #16 Disch SH	AV: 494	C16_Disch SH	*30615	*ADF: 495
Compressor #16 Suct SH	AV: 495	C16_Suct SH	*30613	*ADF: 496
Compressor #16 Oil Pres Diff	AV: 531	C16_Oil Pres Diff	*30663	*ADF: 532
Compressor #17 FLA%	AV: 496	C17_FL A%	*30580	*ADF: 497
Compressor #17 Sat Suction	AV: 499	C17_Sat Suct	*30616	*ADF: 500
Compressor #17 Sat Disch	AV: 500	C17_Sat Disch	*30618	*ADF: 501
Compressor #17 Disch SH	AV: 501	C17_Disch SH	*30619	*ADF: 502
Compressor #17 Suct SH	AV: 502	C17_Suct SH	*30617	*ADF: 503
Compressor #17 Oil Pres Diff	AV: 532	C17_Oil Pres Diff	*30664	*ADF: 533
Compressor #18 FLA%	AV: 503	C18_FL A%	*30581	*ADF: 504
Compressor #18 Sat Suction	AV: 506	C18_Sat Suct	*30620	*ADF: 507
Compressor #18 Sat Disch	AV: 507	C18_Sat Disch	*30622	*ADF: 508
Compressor #18 Disch SH	AV: 508	C18_Disch SH	*30623	*ADF: 509
Compressor #18 Suct SH	AV: 509	C18_Suct SH	*30621	*ADF: 510
Compressor #18 Oil Pres Diff	AV: 533	C18_Oil Pres Diff	*30665	*ADF: 534
Compressor #19 FLA%	AV: 510	C19_FL A%	*30582	*ADF: 511
Compressor #19 Sat Suction	AV: 513	C19_Sat Suct	*30624	*ADF: 514
Compressor #19 Sat Disch	AV: 514	C19_Sat Disch	*30626	*ADF: 515
Compressor #19 Disch SH	AV: 515	C19_Disch SH	*30627	*ADF: 516
Compressor #19 Suct SH	AV: 516	C19_Suct SH	*30625	*ADF: 517
Compressor #19 Oil Pres Diff	AV: 534	C19_Oil Pres Diff	*30666	*ADF: 535
Compressor #20 FLA%	AV: 517	C20_FL A%	*30583	*ADF: 518
Compressor #20 Sat Suction	AV: 520	C20_Sat Suct	*30628	*ADF: 521
Compressor #20 Sat Disch	AV: 521	C20_Sat Disch	*30630	*ADF: 522
Compressor #20 Disch SH	AV: 522	C20_Disch SH	*30631	*ADF: 523
Compressor #20 Suct SH	AV: 523	C20_Suct SH	*30629	*ADF: 524
Compressor #20 Oil Pres Diff	AV: 535	C20_Oil Pres Diff	*30667	*ADF: 536

*- Indicates value multiplied by 10 to include one decimal place. (I.e. BMS value of 500 indicates actual value 50.0)

29.7. Network inputs to MCS-Magnum

The MCS-Magnum can receive changes from the network to enable or disable the Network Run/Stop, Network Target Reset (adjustments to the Cooling Target, Setpoint #1, based on Setpoint #21), Network Demand FLA, and Network Demand Steps.

The MCS-Magnum must be setup to accept these inputs. The configuration file must contain a Network Run/Stop, Network Target, Network Demand FLA, and Network Demand Steps sensors.

Magnum	BACnet ID	BACnet Name	Modbus	N2
Network Run/Stop	AV:246	Net_R/S	40201	BO:247
Network Target/Reset	AV:247	Net_Tar/Res	40202	AO:248
Network Demand/FLA	AV:248	Net_Demad_FLA	40204	AO:249
Network Demand/Steps	AV:249	Net_Demad_Steps	40205	AO:250

Note the following Information panel has a Network Run/Stop, and /or Network Target Reset sensors inputs indicated. This is an example of how MCS-Config must be setup in the General Information and Evaporator Information panels.

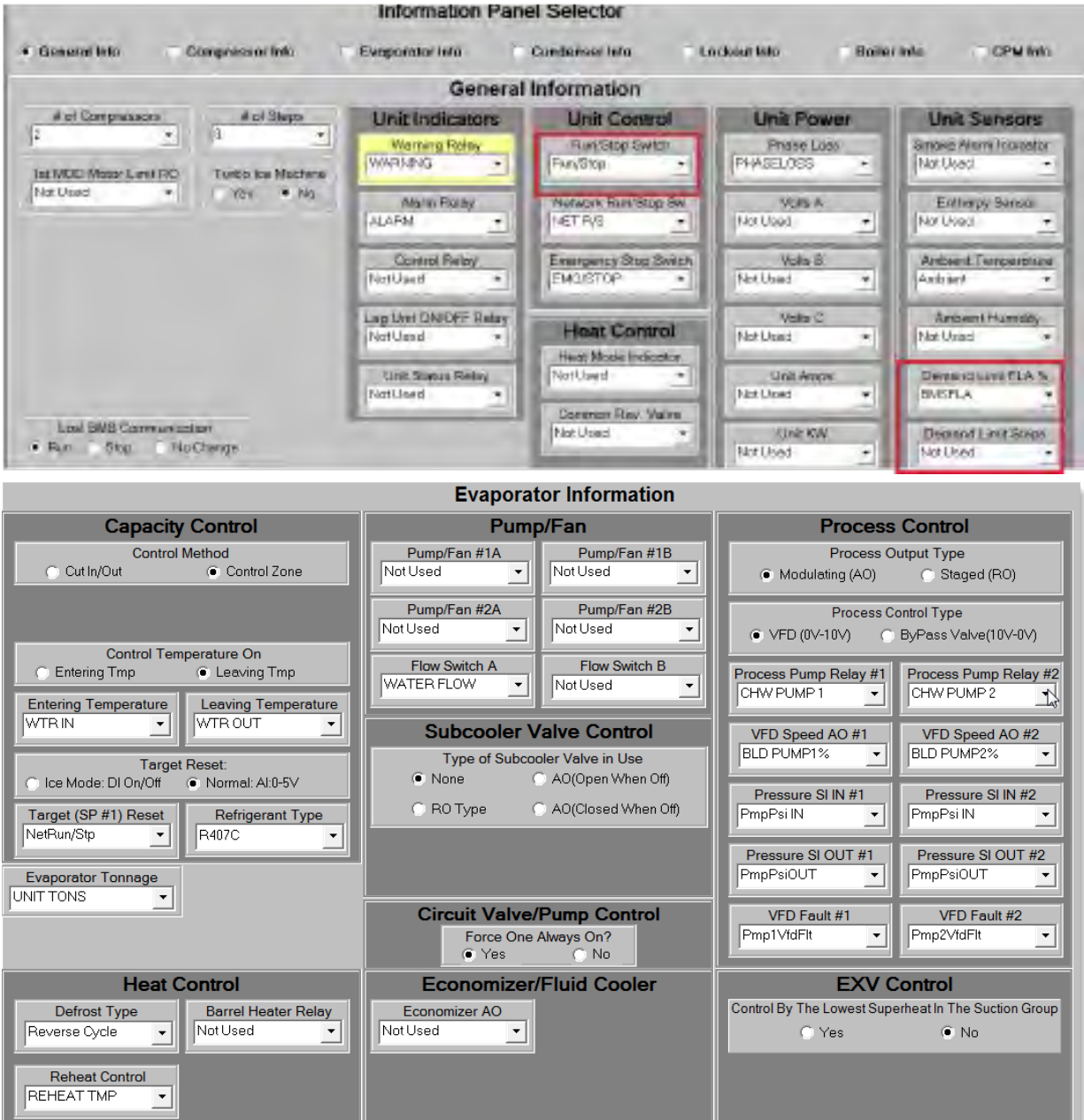

The sensors must be set up as follows (This is only an example)

1-1	BMS R/S	BMS RUN	Not Used	Open=OFF	OFF/ON	Not Used	Not Used	Auto
1-2	BMS TRS	BMS CW RSET	0	0	Not Used	Not Used	Not Used	Auto
1-3	BMSFLA	BMS Dmd FLA%	0	0	Not Used	Not Used	Not Used	Auto
1-4	BMSSteps	BMS Dmd Step	0	0	Not Used	Not Used	Not Used	Auto

Chapter - 30. REFR Unit and Compressor State Chart

BMS Points Unit State Chart		
State #	State #	
MCS & Modbus	BACnet	State Text/Name
0	1	UNIT IN POWER UP
1	2	POWER LOSS DELAY
2	3	NO RUN- I/O LOST
3	4	UNIT IN LOCKOUT
4	5	UNIT IS OFF
5	6	UNIT IS HOLDING
6	7	UNIT UNLOADING
7	8	UNIT IS LOADING
8	9	NO RUN - SAFETY
9	10	RUN/STOP SW OFF
10	11	SCHEDULED OFF
11	12	OFF-NO FLOW(s)
12	13	OFF-NO COND FLOW
13	14	AMBIENT OFF
14	15	PROCESS HEAT OFF
15	16	UNIT IS UNLOADED
16	17	UNIT IS LOADED
17	18	OFF TMP-ICE MADE
18	19	ECONOMIZER ONLY
19	20	SWITCHING MODES
20	21	DEF-STARTING CMP
21	22	DEFROSTING COILS

BMS Points Unit Mode Chart		
State #	State #	
MCS & Modbus	BACnet	State Text/Name
0	1	CHILLER MODE
1	2	ICE MAKING MODE
2	3	HEATING MODE
3	4	DEHUMID MODE
4	5	VENT ONLY
5	6	DEHUMID MODE
6	7	OFF
7	8	SWITCHING MODES
8	9	COOLING w/HEAT
9	10	HEATING w/COOL
10	11	DEFROSTING

BMS Points RTU Building Mode Chart		
State #	State #	
MCS & Modbus	BACnet	State Text/Name
0	1	LOST IO LOCKED
1	2	CMP LOCKED OUT
2	3	SWITCHED OFF
3	4	UNLD & PMPDWN
4	5	CMP ANTICYCLE
5	6	CMP OFF/READY
6	7	OIL PMP LUBING
7	8	CMP IS RUNNING
8	9	CMP UNLOADED
9	10	CMP UNLD STEP1
10	11	CMP UNLD STEP2
11	12	CMP IS HOLDING
12	13	CMP IS LOADING
13	14	CMP IS UNLNDING
14	15	CMP IS RUNNING
15	16	FAST UNLOADING
16	17	LO SUCT UNLOAD
17	18	LO SUCT HOLD
18	19	HI DISC UNLOAD
19	20	HI DISC HOLD
20	21	SAFETY TRIPPED
21	22	LO TEMP UNLOAD
22	23	HI AMP UNLNDING
23	24	HI AMP HOLD
24	25	HI DIS TMP HLD
25	26	CMP IS AT 40%
26	27	CMP IS AT 70%
27	28	HI WATER HOLD
28	29	DEFROST EVAP#1
29	30	DRIP DOWN #1
30	31	DEFROST EVAP#2
31	32	DRIP DOWN #2
32	33	DEF-START COMP
33	34	DEF-PUMP DOWN
34	35	DEFROST COILS
35	36	DEF-AIR NORMAL
36	37	DEF-AIR HOTGAS
37	38	CMP OFF/D-DOWN
38	39	CMP OFF/DefAIR

MCS-MAGNUM BMS PROTOCOLS

The following Protocols are available with the Magnum. Changes can be made to the settings using the Keypad or can be made using MCS-CONNECT SERVICE WINDOW.

1. BACnet IP
2. MCS PROTOCOL
3. MODBUS RTU PROTOCOL
4. ETHERNET PROTOCOL (this protocol is always active)
5. MODBUS IP (this protocol is always active)

30.8.1 BACNET OVER IP PROTOCOL

The BACNET DEVICE ID is a five-digit number. The first three digits are based on MCS's Bacnet Vendor ID 181, and the last two are set by the Bacnet/MSTP address.

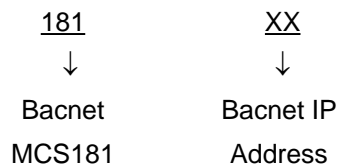

In case the end user would like to set up an ID other than 181-XX, there is an extended BACnet setting that can only be set in MCS Config.

The following changes can be made using the Keypad or can be made using MCS-CONNECT SERVICE WINDOW.

The **BACnet IP** address can be verified and changed (with the proper authorization code) from the Keypad/LCD. The following steps will display the Bacnet IP Network address, and the the TCP/IP port:

- Press the Menu key, select Serv Tools, and then press the Enter key.
- Use **↑** arrow to **BACnet Setting** then press Enter.
- Select address then press Enter. Change the address so it matches the last two digits of the device ID then press Enter.
- Use **↓** arrow to tab to the TCP/IP address.
- Select address then press Enter. Change the address and port to match your device.

30.8.2 ETHERNET NETWORK PROTOCOL

The following steps will display the **ETHERNET NETWORK** settings:

If you are going to manually assign the IP Address, Subnet Mask, and Default Gateway.

- Press the Menu key, select Serv Tools, and then press the Enter key.
- Select Ethernet Network then press Enter.
- Set "DYNAMIC IP" to NO.
- Set the "IP Address".
- Set the "Subnet Mask".
- Set "Default Gateway".
- Reset Magnum for change to take effect.

If you are going to let your network assign the IP Address, Subnet Mask, and Default Gateway:

- Press the Menu key, select Serv Tools, and then press the Enter key.
- Select Ethernet Network then press Enter.
- Set "DYNAMIC IP" to YES.
- Connect the MCS-Magnum to the network and power up the board.

29.7.1 MODBUS RTU PROTOCOL

The Modbus RTU address can be verified and changed (with the proper authorization code) from the keypad/LCD or can be made using MCS-CONNECT SERVICE WINDOW.

The following steps will display the Modbus RTU Network address, and the Baud Rate:

- Press the Menu key, select Serv Tools, and then press the Enter key.
- Select RS485 Network then press Enter.
- Select Protocol then press Enter. Change the protocol to Modbus RTU.
- Select address then press Enter. Change the address then press Enter.
- Select Baud then press Enter. Set the baud rate then press Enter.
- Connect the communication wires to the TX RS485 three-position terminal located above the Ethernet connector.
- Reset Magnum for change to take effect.

29.7.2 MODBUS TCP/IP PROTOCOL

This protocol is always active.

Make sure the MCS-Magnum network settings are set correctly.

If you are going to manually assign the IP Address, Subnet Mask, and Default Gateway.

Press the Menu key, select Serv Tools, and then press the Enter key.

- Select Ethernet Network then press Enter.
- Set "DYNAMIC IP" to NO.
- Set the "IP Address".
- Set the "Subnet Mask".
- Set "Default Gateway".
- Reset Magnum for change to take effect.

If you are going to let your network assign the IP Address, Subnet Mask, and Default Gateway:

- Press the Menu key, select Serv Tools, and then press the Enter key.
- Select Ethernet Network then press Enter.
- Set "DYNAMIC IP" to YES.
- Connect the MCS-Magnum to the network and power up the board.

29.8. PROTOCOLS USING MCS-BMS-GATEWAY

The MCS-BMS-GATEWAY is a microprocessor based communication device that provides translation from BACnet IP to LonTalk, BACnet MSTP, or Johnson Control N2.

Information that can be transmitted includes the status of control points, alarm information, digital inputs, analog inputs or setpoints.

For more information on the MCS-BMS-GATEWAY please go to www.mcscontrols.com.

Chapter - 31. NETWORK PROTOCOLS

Network protocols are formatting rules that specify how data is sent and received between devices. Protocols are necessary for devices to interact with each other.

31.1. Protocols MCS controllers support:

1. BACNET
2. MODBUS RTU
3. ETHERNET
4. MCS
5. LONTALK
6. JOHNSON N2

MCS Network Protocol Support		
	Magnum	MicroMag
Over Ethernet	Bacnet IP	MCS-Bacnet-Router2
	Modbus IP	In Development
	MCS IP	MCS-Ethernet
Over RS485	Modbus RTU	
	MCS 485	
	Bacnet MS/TP	MCS-BMS-Gateway
Over LonWorks	Johnson N2	MCS-BMS-Gateway
	LonTalk	MCS-BMS-Gateway

✓ = Built in Support

Requires MCS-BMS-GATEWAY

31.2. MCS-MAGNUM USING RS-485

Using the RS485, the MCS-Magnum can be connected to the BMS (Modbus RTU or MCS 485)

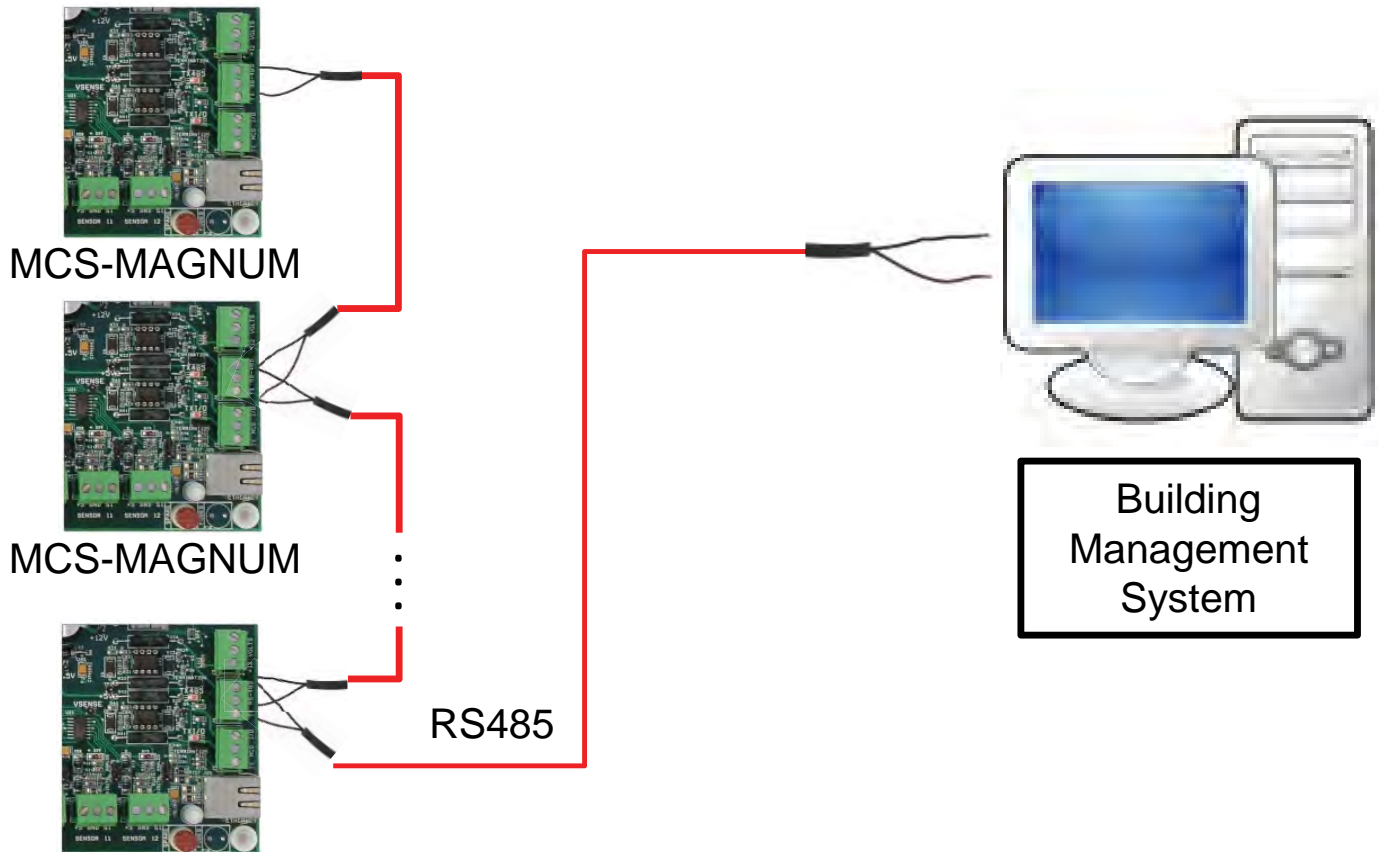

31.3. Wiring Multiple MCS Controllers

- Using the RS485, the network must be wired controller to controller
- Star configurations not allowed
- Up to 30 controllers can be wired together

Wiring Multiple MCS Controllers Using RS-485

Using the RS485, the MCS-Magnum can be connected to the BMS (Modbus RTU or MCS 485)

- Using the RS485, the network must be wired controller to controller.
- Star configurations not allowed.
- Up to 30 controllers can be wired together.



The RS232 cannot be used with different protocols when the RS485 is used.

MCS-MAGNUM #1
or MCS-MicroMag

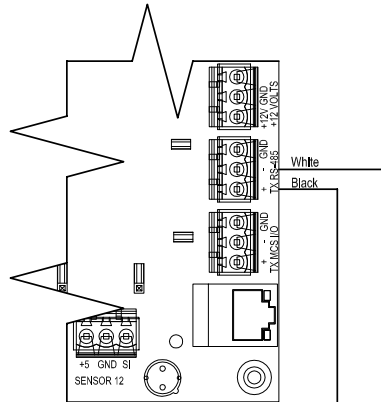

MCS-MAGNUM #2
or MCS-MicroMag

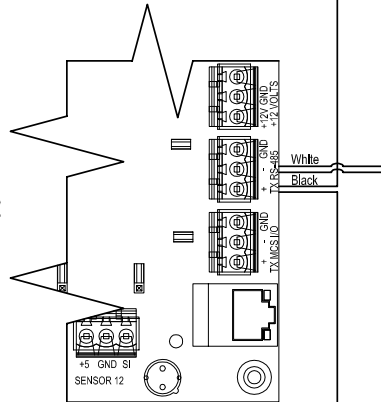

MCS-MAGNUM #3
or MCS-MicroMag

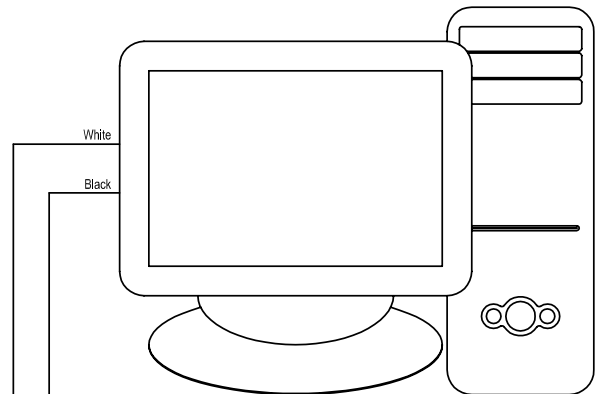
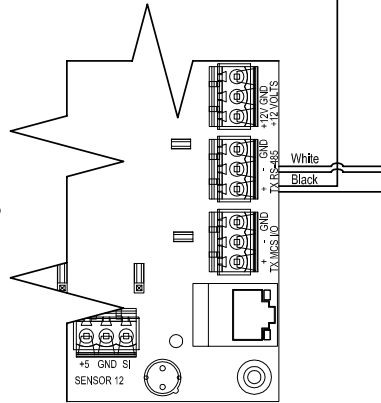

Building
Management
System

31.4. MCS-MAGNUM USING ETHERNET

- Using the Ethernet, the MCS-Magnum can be connected to:
- BMS (Bacnet IP or Modbus IP)
- MCS-Touch (MCS-Connect)
- PC (MCS-Connect)
- Internet access through router (which allows connection via MCS-Connect from anywhere)

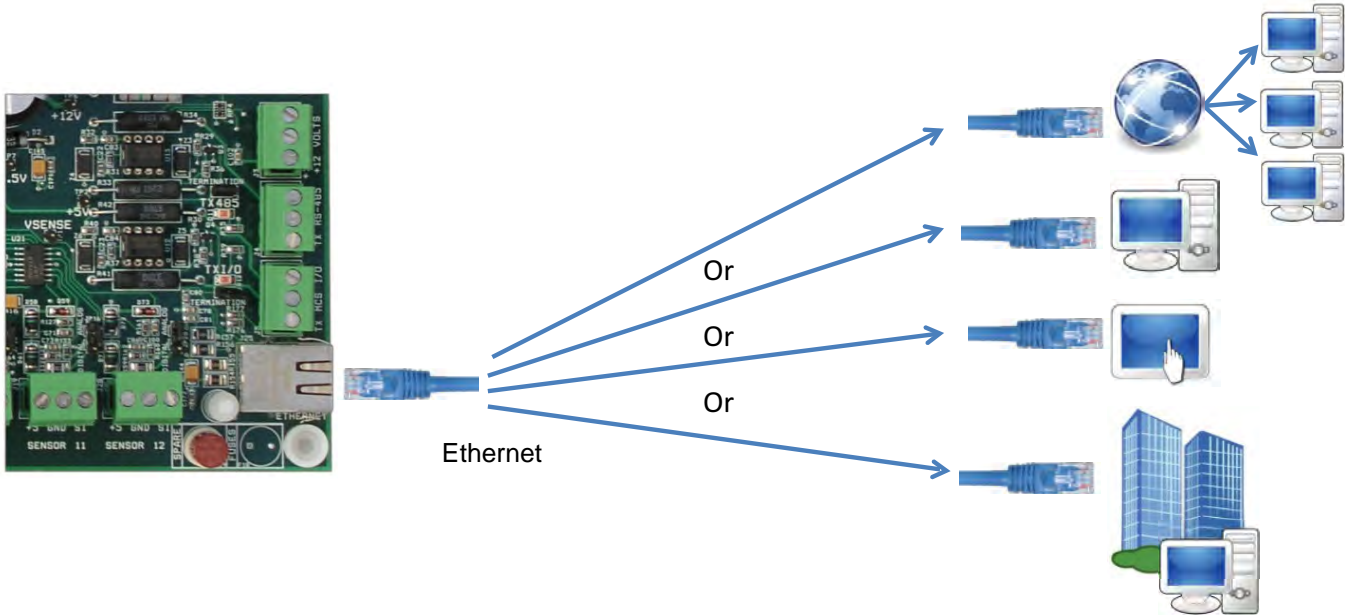

31.5. EXAMPLE NETWORK

31.5.1 Standalone MCS-Magnum

- MCS-Touch
- BMS (Johnson N2 or LonTalk or Bacnet MSTP)
- Internet Access

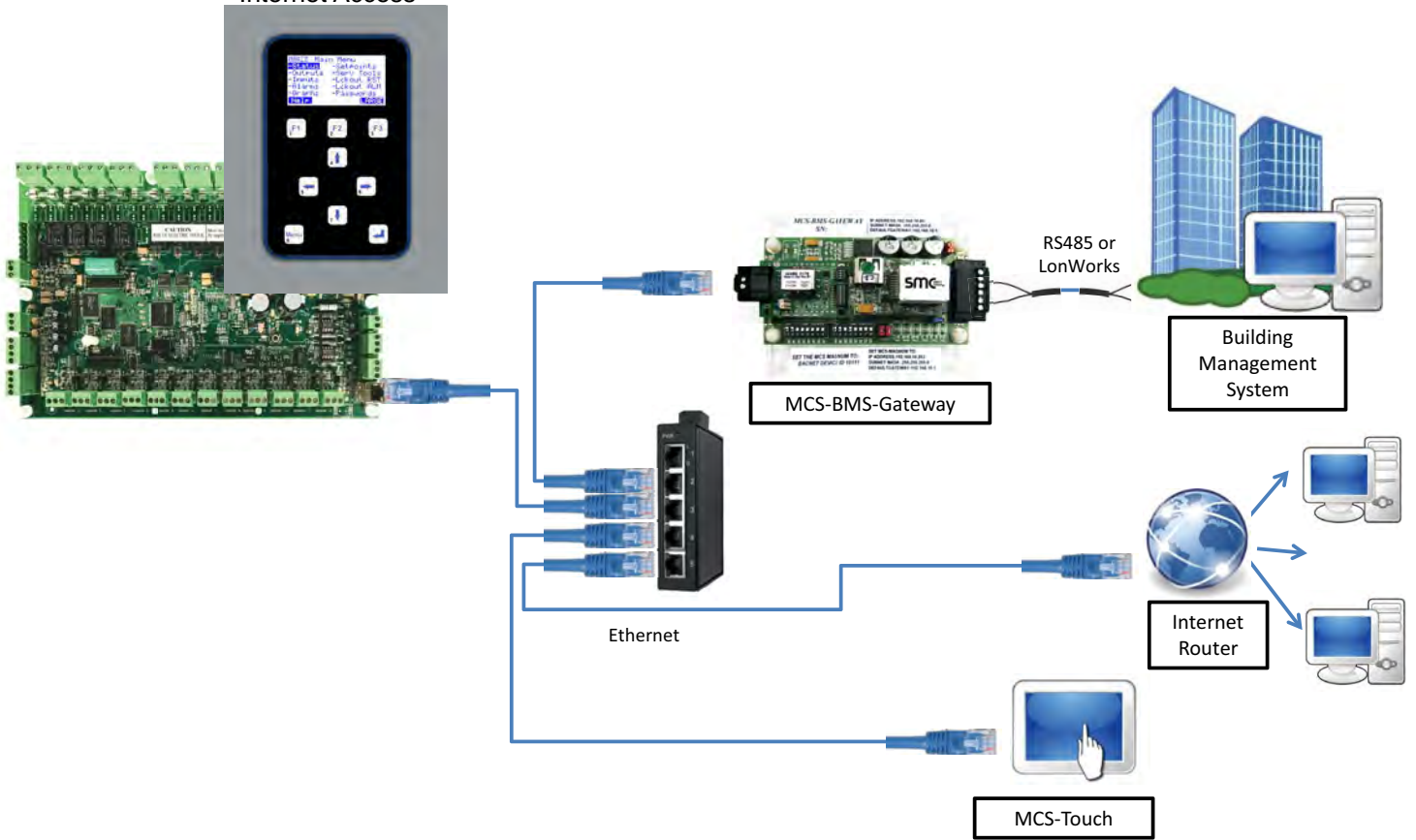

31.5.2 MULTIPLE MCS-MAGNUM ENCLOSURES

- Internet Access
- BMS (Bacnet IP or Modbus IP)

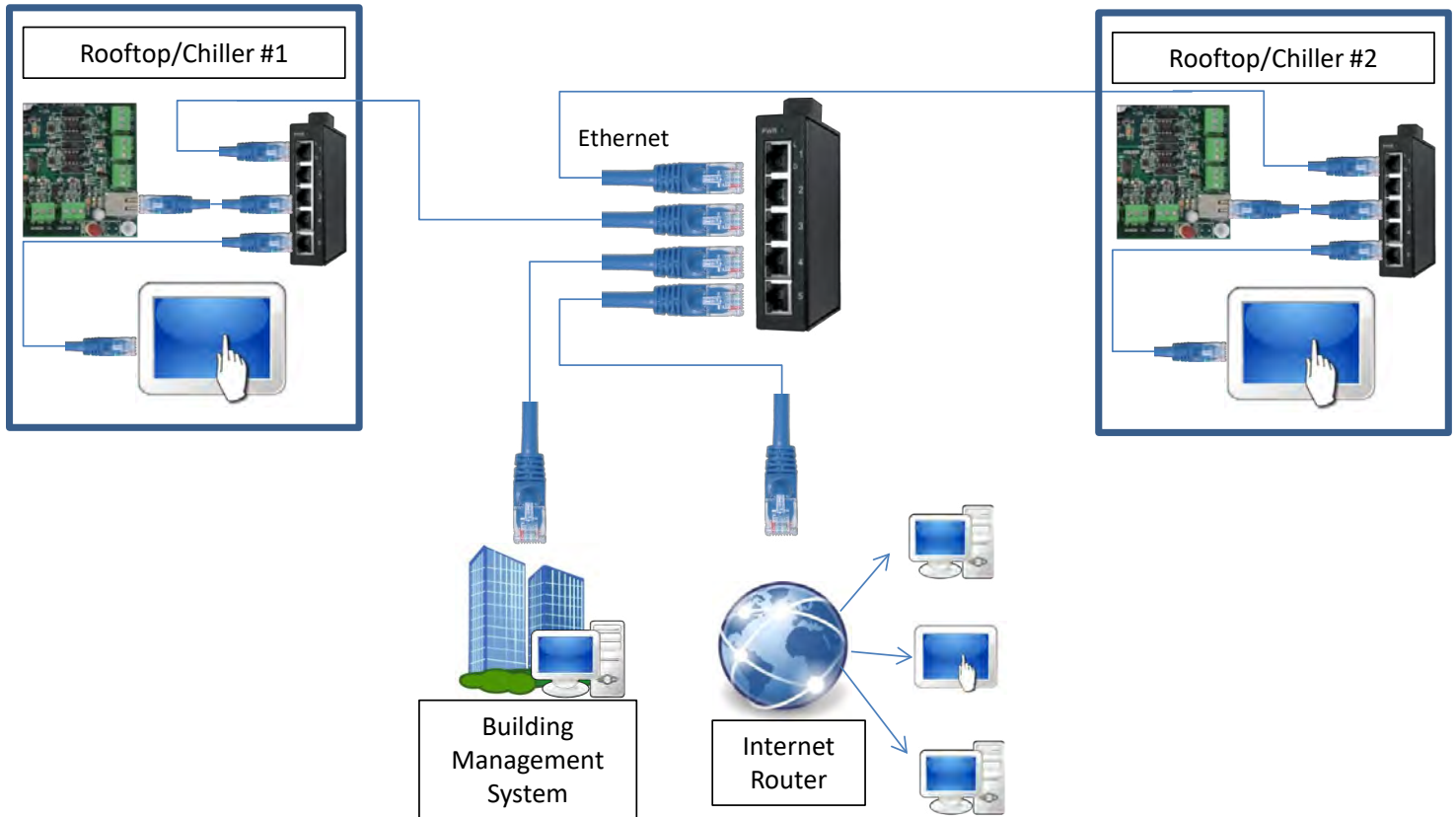

31.6. MULTIPLE MCS-MAGNUM BMS RS485 WIRING DIAGRAM

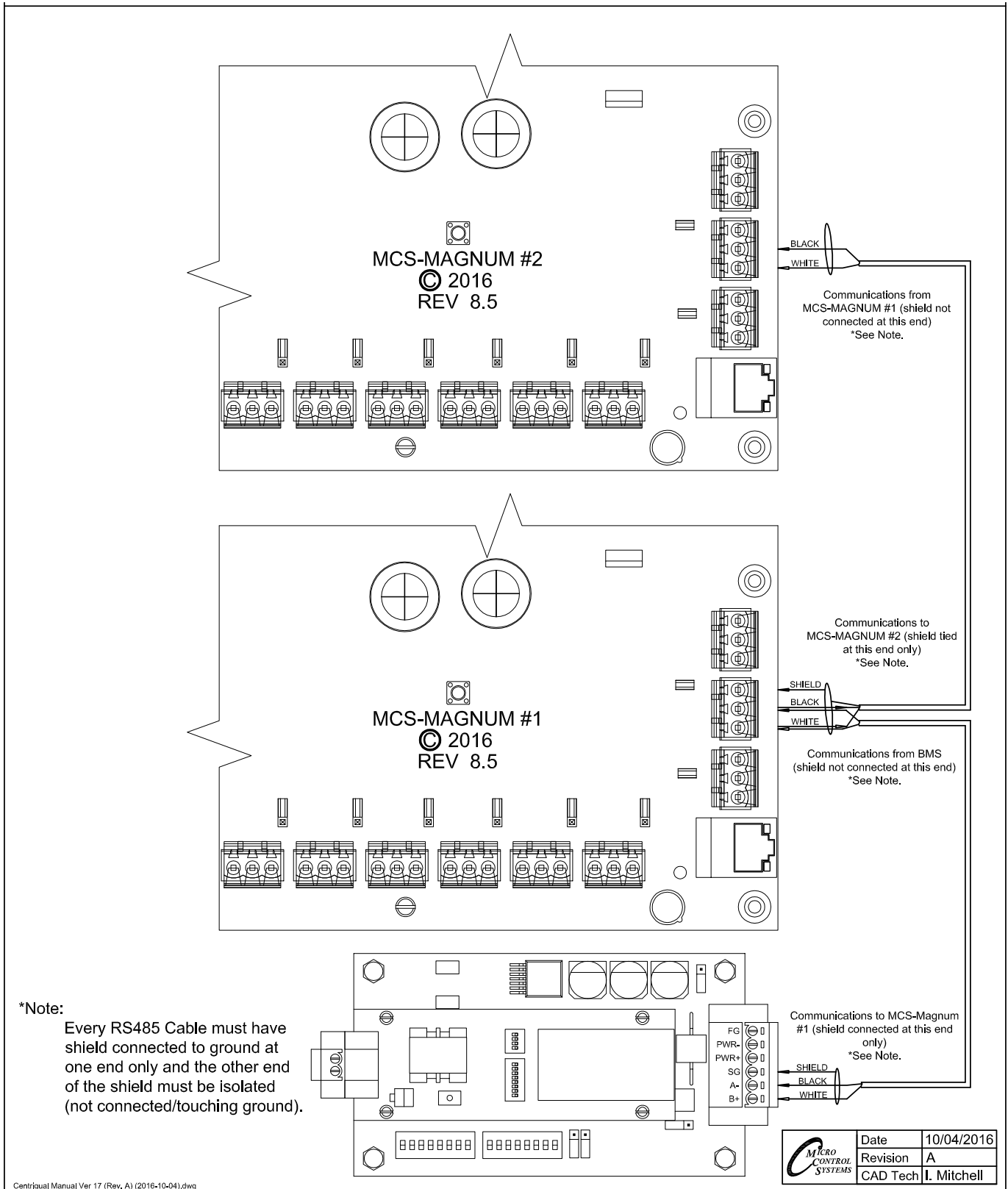

	Date	10/04/2016
	Revision	A
	CAD Tech	I. Mitchell

Centrigual Manual Ver 17 (Rev. A) (2016-10-04).dwg

Chapter - 32. Set Point Definitions

Setpoint Information Screen

#	Name	Value	Min	Max	Adjust Value	Time (SEC)	Max Time Allowed (SEC)	Lockout Delay (HRS)	Safety Down Time(MIN)	Active or Non-Active	Select Value: # decimals & print char	Level Of Auth. To Display	Type of Setpoint	Comments	SEC to Ignore Safety	Window to Ext. Safety Time(SEC)	Safety Time Extension (SEC)
---	------	-------	-----	-----	--------------	------------	------------------------	---------------------	-----------------------	----------------------	---------------------------------------	---------------------------	------------------	----------	----------------------	---------------------------------	-----------------------------

(Number)–From 1 to 255 (maximum number of Setpoints supported). Only active Setpoints will be displayed in MCS-Connect and on the keypad display.

Name–The Setpoint's name consists of up to 12 characters. The name is displayed following the number on the LCD display. The Setpoint name can be changed to make it more meaningful to the current application, however the function of the Setpoint will remain the same.

Value–The value or target of the Setpoint. With proper authorization this value can be changed, within limits that have been established in MCS-Config.

Min–The minimum value that can be set. This field is not displayed and cannot be changed in MCS-Connect or in the keypad display.

Max–The maximum value that can be set. This field is not displayed and cannot be changed in MCS-Connect or in the keypad display.

Adjust Value–The interval that the value field can be changed by. This field is not displayed and cannot be changed in MCS-Connect or in the keypad display.

'Time (sec)' – this field has two purposes:

1) In either a LOCKOUT or ALARM type; this is the length of time the Setpoint must be true before it will trip. This time is always in seconds and it is displayed on the keypad display and MCS-Connect if the Setpoint is either a LOCKOUT or ALARM type. This field can be changed in MCS-Connect and through the keypad.

2) In a non-safety type Setpoint this field can be used as an extra timer. This will be specified in the Setpoint definition if it is used.

Lockout Delay Hrs. – If a second safety occurs within this time, the unit or compressor will be locked out. This field is not displayed and cannot be changed through MCS-Connect or in the keypad display.

Safety Down Time (min.) – After the first safety occurs the Magnum will wait this number of minutes before the unit or associated compressor is allowed to run again.

Active or Non-Active – Only active Setpoints will be displayed in MCS-Connect or on the keypad display, but only if the needed authorization level has been achieved.

Select Value: # decimals and print char – This indicates the number of decimal places and the unit character that accompanies the value displayed. The number of decimal places is crucial when the Value, Minimum, and Maximum data is entered in MCS-Config.

Level of Auth. To Display – This column indicates what authorization level a user must have in order to view the Setpoint from MCS-Connect or the keypad display.

Comments – This column allows the user to add comments about the function of the Setpoint.

BMS Writeable (Click Here to Disable All) – The Magnum software will enable communications with an outside source, building management system (BMS), to modify the value of a set point. Object is to provide maximum flexibility and capability with an BMS.

32.1. Setpoint Types

There are six different types of Setpoints. The Magnum software determines if a Setpoint contains a target value or is a safety. If it is a safety then its type determines what action the Magnum will take when the safety occurs (either locking out the unit or generating an alarm only).

32.1.1 SETPOINT

This type of Setpoint contains a target or provides information for some action. The time element in this type can be used for an additional counter if specified. This time is not displayed and cannot be changed through MCS-Connect or from the keypad display.

32.1.2 LOCKOUT

This type of Setpoint contains a safety value and the time that the safety must be violated before the safety will trip. Once a safety has tripped the Magnum will take the appropriate action, shutting down the entire package or an individual compressor depending on the purpose of the safety. The Magnum will then wait the Safety Down Time contained in that Setpoint before trying to return the normal. If successful, the system will continue to operate. If a second trip occurs on the same Setpoint within the Lock Out Delay Time that is contained in that Setpoint the system will move to a LOCKOUT state. If the lockout delay time is set to zero the lockout will occur on the first trip. This requires manual intervention to reset the system. With each safety trip, the Magnum will generate an alarm; refer to section 8 Magnum Alarms and Safeties.

Sec. to ignore safety - If this value is not zero, at compressor startup this safety will be ignored for the time in this field.

Window to extend Safety 'Time (sec)' – If this value is not zero, at compressor startup the normal Safety Time will be increased by the value in Safety Time Extension field for the time specified in this field.

Safety Time Extension (Sec) – This is the value that will be added to the Safety Time during the Window to extend Safety Time period.

32.1.3 ALARM

This type of Setpoint has two uses:

- 1) When it is used as a safety, it will be similar to the LOCKOUT Setpoint except it will never cause a lock out. The system will continue to try returning to normal operation after waiting the safety down time. An ALARM Setpoint type will never require manual intervention to reset the system.
- 2) When the Setpoint is being used as a second timer it will be available to change in a live unit. If the type is not changed to ALARM then the time field cannot be viewed or changed from a live unit.

Sec. to ignore safety - If this value is not zero, at compressor startup this safety will be ignored for the time in this field.

Window to extend Safety 'Time (sec)' – If this value is not zero, at compressor startup the normal Safety Time will be increased by the value in Safety Time Extension field for the time specified in this field.

Safety Time Extension (Sec) – This is the value that will be added to the Safety Time during the Window to extend Safety Time period.

32.1.4 Time

This type of Setpoint allows the 'Time (SEC)' value to be displayed and modified in a live unit.

32.1.5 Target

This type of set point is used to develop a target with a high and low zone values.

The decimal characteristics of these values are the same as the Value field

High Zone – The value of this cell is added to the Value cell to create the high zone value.

Low Zone – The value of this cell is subtracted from the Value cell to create the low zone value.

Night Setback – If system has an unoccupied mode, this value is used to modify the value of the 'Value' cell.

32.1.6 Delay

This type of set point is used to develop a target with a high and low zone values.

The decimal characteristics of these values are the same as the Value field

High Zone – The value of this cell is added to the Value cell to create the high zone value.

Low Zone – The value of this cell is subtracted from the Value cell to create the low zone value.

Night Setback – If system has an unoccupied mode, this value is used to modify the value of the 'Value' cell.

32.2. Window/Safety extension

32.2.1 Time and seconds to ignore for setpoints

Seconds to ignore – This is the time in seconds to ignore the associated safety at compressor start up.

The window to extend safety time and safety time extension fields work together.

Window to extend safety – This value in seconds is the time window when the compressor starts that the **safety time extension** is added to the safety **time(sec)** value.

Safety time extension – This value is the time that is added to the **time(sec)** value during the **window to extend safety time(sec)** time.

Example – Unsafe suction setpoint has a 3 second safety trip. So if we add a 120 to our window to extend safety, we will then be telling the controller at startup we’re going to extend that 3 second safety trip for 120 seconds. This is where the Safety time extension comes into play. If we put a 6 in this field we’re telling the controller for the first 120 seconds at startup we’re extending the safety trip time to 9 seconds (3 second trip plus the 6 second extension). Once the 120 seconds expires we will then revert back to a 3 second trip time for the duration of the compressors run time till the next startup.

System Setup ROs SIs AOs MAG HVAC Circuit Base Circuit SI Setpoints Auth Schedule BMS Points Lookup Table																
Setpoint Information Screen																
Name	Value	Min	Max	Adjust Value	Time (SEC)	Max Time Allowed (SEC)	Lockout Delay (HRS)	Safety Down Time(MIN)	Active or Non-Active	Select Value: # decimals & print char	Level Of Auth. To Display	Type of Setpoint	Comments	SEC to Ignore Safety	Window to Ext. Safety Time(SEC)	Safety Time Extension (SEC)
LOW SUCTION	55	35	65	1	90	120	2	10	Active	... PSI GAGE	View Only	Lockout	...	5	900	120
LO SUCT UNLD	2	2	6	1	0	0	0	0	Active	... PSI GAGE	View Only	Setpoint	...	---	---	---
LO SUCT RELD	5	3	8	1	0	0	0	0	Active	... PSI GAGE	View Only	Setpoint	...	---	---	---
UNSAFE SUCT	10	5	25	1	3	3	0	0	Active	... PSI GAGE	View Only	Lockout	...	3	120	6

32.3. Set points for MAG REFR V17 Software

1	CTL TARGET	Control target. This value is used as the base to develop the Control Zone. Refer to setpoints # 2 and #3. The control target is used with the control zone and rate of change of the controlling sensor to determine required action for the system. The controlling sensor is usually one of the following: Leaving Temperature – Most common used as a target, fitting for most applications. Return Temperature – Used in sites with large air masses, ice rinks, common areas, etc. Suction Pressure – Used in continuously running process systems.
2	CTL ZONE +	Added to the CTL TARGET to create the upper limit of the control zone.
3	CTL ZONE -	Subtracted from the CTL TARGET to create the lower limit of the control zone.
4	HGS TEMP ON	This setpoint is used with screw compressors with a hot gas bypass solenoid. When this setpoint is active and the control temperature is less than the CTL TARGET plus the value in this setpoint and the FLA % is within 25% of setpoint #31 "MIN SLIDE%", the hot gas bypass solenoid for the compressor will be turned on. 'Time (sec)' field: If this field is not zero, it is added to setpoint #31 to determine when the hot gas solenoid is to be turned on. If zero, then the value of 2.5 is added.
5	HGS TEMP OFF	This setpoint is used with screw compressors with a hot gas bypass solenoid. When this setpoint is active and the control temperature is greater than the CTL TARGET plus the value in this setpoint or the FLA % is not within 25% of setpoint #31 "MIN SLIDE%", the hot gas bypass solenoid for the compressor will be turned off. 'Time (sec)' field: If this field is not zero, it is added to setpoint #31 to determine when the hot gas solenoid is to be turned off. If zero, then the value of 3.0 is added.
6 **	HGS PSI ON not used	This setpoint is used with screw compressors with a hot gas bypass solenoid. When this setpoint is active and the suction pressure is less than the value of this setpoint and the FLA % is within 25% of the setpoint #31 "MIN SLIDE%", the hot gas bypass solenoid for the compressor will be turned on.
7 **	HGS PSI OFF not used	This setpoint is used with screw compressors with a hot gas bypass solenoid. When this setpoint is active and the suction pressure is greater than the value of this setpoint or the FLA % is not within 25% of the setpoint #31 "MIN SLIDE%", the hot gas bypass solenoid for the compressor will be turned off.
8 **	L.INJECT.ON not used	This setpoint can be used for both liquid injection solenoids. Value: Liquid injection is turned on when the discharge temperature is greater than or equal to this setpoint, and is turned off when the discharge temperature is less than this setpoint minus 10.0°F (5.5°C). 'Time (sec)' field: If the first liquid injection solenoid has been on for a time greater than this value, then turn on the second liquid injection solenoid.
9	SPRHT TARGET or LEVEL TARGET	If EXV control is based upon superheat, this is the Superheat target that the system will control from. If EXV control is based upon refrigerant level, this is the refrigerant level target that the system will control from. 'Low Zone' if nonzero then develop control super heat based upon the lowest superheat of any compressor that is on with in this suction group else use the superheat of this compressor. 'Time (sec)' field: Seconds between samples used for calculating the Superheat Rate of Change.
10	SPRHT ZONE +-	The value in this setpoint is added and subtracted to setpoint #9 to determine the upper and lower limits of the control zone respectively. 'Time (sec)' field: If non-zero, skip ROC adjustment logic in the control zone.

11	EXV LOAD ADJ	The opening adjustment that will be made to the EXV percentage when the circuit changes to the Loading state, or the closing adjustment that will be made when the circuit changes to the Unloading state. Note: In MOP hold state, only closing adjustments are allowed.
12	EXV FINE ADJ	The adjustment is made when in the 1st zone above or below the control zone. Refer to section on EXV control.
13	EXV COURSE	If a course adjustment to the EXV when in the 2nd zone above or below the control zone. If the type is TIME and the time (SEC) field is greater than 1 and less than 7 then multiple the value field by the time field else multiple by 2 for adjustment amount. If a course adjustment to the EXV when in the 3rd zone above or below the control zone. Multiple value by the by 2 for adjustment amount. If a course adjustment to the EXV when above or below the 3rd zone the control zone. The value is the adjustment amount. Refer to section on EXV control. If a course adjustment to the EXV when in the 3rd zone above or below the control zone. Multiple value by the by 2 for adjustment amount. If a course adjustment to the EXV when above or below the 3rd zone the control zone. The value is the adjustment amount. Refer to section on EXV control.
14	EXV LOAD DIV	The EXV slide adjustment can be fined tuned by dividing by the value of this set point. Note the value of this set point is used regardless if the set point is active or not.
15	EXV MIN %	This is the minimum valve position allowed when modulating the expansion valve. This value should be set so when hot gas is applied the valve opening is adequate. Note the value of this set point is used regardless if it is active or not. Refer to section on EXV control. Note the value of this set point is used regardless if it is active or not.
16	EXV MAX %	This is the maximum position allowed when modulating the expansion valve to maintain the superheat target. This value should be the valve % opening at full capacity plus a 10 to 15 % margin.
17	LO SUPERHEAT	If super heat is less or equal to this value and the control slope is less that the roc for zone 3, make a slide adjustment of 3 times the value of set point #13. If the calculated superheat remains below this value for the time specified in the Time (SEC) cell, the Magnum will generate a LOW SUPERHEAT alarm. Refer to section on EXV control.
18	LOWSUCPSI DLY	Delay in seconds when in 'Low Suction PSI Opening' between adjustments to the EXV valve.
19	EXV DELAY	Delay in seconds between valve adjustments. Should not be less than 48. (When adjusting at 4x this will allow 12 seconds for the controller to process the results of the last action before making the next adjustment)
20	EXV STRT TIME	This is the time in seconds to hold the valve at the start % setpoint when the compressor starts. Since the superheat calculation is not valid when the compressor is not running the EXV logic sets the valve to a given position for a set time to allow the system to develop a valid superheat. 'Time (sec)' field: If zero, then there is no delay when a compressor is ready to start. If non-zero, this is the time delay in which the EXV valve is allowed to open before the compressor starts.

21 **	MAX TRG RESET not used	This value is used to adjust setpoint #1 "CTL TARGET". The sensor input value will vary between 0 and 5 volts and the adjustment to the control target will be modulated from negative "MAX TRG RESET" to the positive "MAX TRG RESET" value.
22	LOW AMBIENT	If the ambient temperature is below this value the system will be disabled and the unit state will be AMBIENT OFF. The unit will remain off until the ambient temperature rises above this setpoint value by 5.0F (2.5C).
23	POWERUP DELAY	The time in seconds that the system will remain in the START UP state before moving to the next state.
24	HI AMBIENT	If the ambient temperature is above this value the system will be disabled and the unit state will be AMBIENT OFF. The unit will remain off until the ambient temperature drops below this setpoint value by 5.0F (2.5C).
25	STEP SENSTIY	This value is used to adjust the rate of response to changes in the control algorithm. 1 is the fastest response, whereas higher numbers will mean a more gradual response. Used only with the Magnum Control Zone control method.
26	STEP DELAY	Value: This is the time delay before making adjustments to the system capacity. Used with both the Magnum Control Zone and Voltage Step control method. 'Time (sec)' field: If used, this will force a minimum time delay between any two compressor starts. This time delay is specified in the 'Minimum Delay Between Compressor Starts' box in the 'Compressor Information' section under the MAG REFR tab.
27	MAX ROC -	Maximum negative Rate of Change allowed before preventing the unit from loading. If the ROC is less than this value the capacity control state is set to HOLDING. Used only with the Magnum Control Zone control method.
28	MAX ROC +	Maximum positive Rate of Change allowed before preventing the unit from unloading. If the ROC is greater than this value the capacity control state is set to HOLDING. Used only with the Magnum Control Zone control method.
29	ROC INTERV	Seconds between samples used for calculating the Rate of Change. Used only with the Magnum Control Zone control method. (Maximum 60 seconds)
30	MAX FLA % or MAX VFD %	Indicates the maximum amp draw or speed allowed. Usually set to 100%, else compressors will load to the value of this setpoint until all steps are on, then the system will load to 100%. 'Time (sec)' field: If non-zero, then force individual compressors to stay at maximum capacity when another compressor starts. This option is selected in the 'Keep Running Comp at 100% when starting next?' box in the 'Compressor Information' section under the MAG V8 tab.
31	MIN FLA % or MIN VFD %	Value: Indicates the minimum amp draw or speed allowed (usually 40%). This is where the slide valve or VFD will be set when the compressor is turned on. This % is a function of actual amp draw relative to the FLA. 'Time (sec)' field: If used, this forces a time delay before unloading all running compressors before the next compressor is started. This time delay is specified in the 'Unload Compressor Before Starting Next' box in the 'Compressor Information' section under the MAG V8 tab. 'Target' field: Adds support to force the digital compressor speed to a different min value if only the digital compressor is running on the suction group. In order to use this new logic you must make setpoint #31 "Min Spd%" a "TARGET" type and put in the Low Zone column the min speed value you want to running the digital compressor when only the digital compressor is running on the suction group.
32	MAX ADJUST %	Indicates the maximum percentage change that can be made to the slide valve or VFD. 'Time (sec)' field: A zero indicates that the calculated FLA will be used, else the value in setpoint #31 will be used when starting the next compressor. This value is specified in the 'Wanted FLA starting next Compressor' box in the 'Compressor Information' section under the MAG V8 tab.

33	MIN ADJUST %	Indicates the minimum percentage change that can be made to the slide valve or the VFD.
34	SLIDE SENSITY	This controls the sensitivity of the adjustment made to the Wanted Percentage (adjustments are relative to the difference between the current control sensor and target). The larger the value the larger the adjustment (usually 1).
35	LOAD PULSE	Length of time to engage the slide valve load solenoid in tenths of a second (usually between 1 and 9). 'Time (sec)' field: If non-zero, use this value as a multiplier to increase the load pulse when the compressor's amp draw is more than twice the value of setpoint #36 "AMP DB LO".
36	UNLOAD PULSE	Length of time to engage the slide valve unload solenoid in tenths of a second (usually between 1 and 9).
37	LUBE OIL TMP	Safety. If oil seal temperature sensor and this set point is active then when the compressor is running the oil temperature will be checked for a low condition based on the values in this set point.
38 **	LUBE OIL PSI not used	The oil must reach this pressure before the circuit will move out of the LUBE state.
39	LUBE DELAY	This is the maximum time that a compressor can be in the LUBE state. When this time is exceeded, an alarm is generated and the compressor is locked out. Both the oil temperature and pressure must be satisfied before the LUBE state will be exited. Refer to the OIL PMP LUBING state.
40	CND STG1 ON (Air cooled)	When the discharge pressure is above this value, turn on the first stage of the condenser fans. 'Time (sec)' field: (Applies to compressors with shared condensers) If non-zero, then the compressor in startup state will not be in sole control of the condenser fans, it will control off of highest discharge pressure. If zero, then compressor in startup will have sole condenser control for 5 minutes. This option is selected in in the 'Newly started Comp Controls Common Fan Bank' box in the 'Condenser Information' section under the MAG V8 tab.
	PID MOD Individual PID Step Comm	If active, multiplier uses PID condenser control KP (Proportional). Setup as setpoint.
41	CND STG1 OFF (RO Type)	If stage 1 of condenser capacity is on and the discharge pressure drops below this value, then turn this stage off.
	PID MOD Individual PID Step Common	If active, uses Multiplier for Ki adjustments (Integral Time Delay). Setup as setpoint
42	CND DIFF ON (RO Type)	Differential pressure added to setpoint #45 to set the threshold at which each additional stage of condenser capacity will turn on.
	PID MOD Individual PID Step Common	If active, uses Multiplier for Kd adjustments, (ROC Time Delay). Setup as Target.
44	CND MIN RUN (Modulating Type)	Once a condenser stage has been turned on, it will remain on for at least the amount of minutes specified in this setpoint.
	DUAL TIME DELAY (Dual V8)	Time delay once the pressure difference in setpoint #48 has been reached before the second condenser stage can be started.
45 **	LO AMB COND OFF not used	
46	CND PSI TARG (Modulating Type)	Target discharge pressure which the condenser valve will try to maintain by modulating open or closed.

47	CND ADJ DIV (Modulating Type)	Controls scaling of the amount the valve is adjusted (Usually 1). The larger the number the smaller the valve adjustment as the adjustment will be divided by this value.
	CND VFD MIN	If there is a VFD associated with the condenser, this is the starting minimum speed. 'Time (sec)' field: This field contains the condenser stage that must be on before the VFD is modulated.
48	CND MIN SPD (Modulating Type)	Minimum valve opening percentage allowed. If the compressor is off, then check the 'Time (sec)' field: If 0, then set the VFD to the value of this setpoint. If 2 and the run/stop is set to run, then set the VFD to 100%, else set the VFD to 0%. This option is selected in in the 'Default Valve Opening % when Comp. is OFF' box in the 'Condenser Information' section under the MAG V8 tab.
49	CND ROC- (Modulating Type)	Maximum negative discharge pressure rate of change allowed. If the rate of change is less than this setpoint, then stop opening the valve. The absolute value of this setpoint also serves as the maximum positive rate of change allowed. If the rate of change is greater than the absolute value of this setpoint, then stop closing the valve.
50	CND MIN SPD (Modulating Type)	Minimum speed percentage for variable speed condenser control.
	CND ADJ MULT (Modulating Type)	Allows scaling of the amount the valve is adjusted. The larger the number the larger the valve adjustment will be multiplied by this value.
51	CND MAX SPD (Modulating Type)	Maximum speed percentage for variable speed condenser control.
52	COND LOW AMB	Standard condenser logic dictates that a newly started compressor will use its own discharge pressure as the control for the first five minutes. If this setpoint is active and the ambient temperature sensor is reading less than the value of this setpoint, then this compressor's discharge pressure will remain in control for the additional time in seconds as specified in the 'Time (sec)' field.
53 **	LOW AMBIENT OFF not used	
54	COND HI AMB	If active, standard condenser control on compressor startup logic will be bypassed when there is a high ambient temperature. If the condenser type is common and the ambient temperature is above the value of this setpoint, then the compressor with the highest discharge pressure will have control of the condenser.
55	COND FAULT	For Condensers with Fault Indicators: If setpoint is active, a condenser fault occurs, and the setpoint type is Alarm, then an alarm message will be generated. If the type is Lockout, and a condenser fault occurs, then all of the compressors associated with this fault will be locked off. For Common VFD Fan Condensers with Bypass: Time in seconds before the bypass can be used when a fault has occurred.
56	COND PHASE Fault 1	If this set point is active and a digital input has been selected for the Condenser Phase Failure 1 when the compressor is on this digital input will be checked. If the digital input is on for the Time specified for this set point, the circuit will enter a safety state and an alarm will be generated indicating which circuit has the failure.
57	COND PHASE Fault 2	If this set point is active and a digital input has been selected for the Condenser Phase Failure 2 when the compressor is on this digital input will be checked. If the digital input is on for the Time specified for this set point, the circuit will enter a safety state and an alarm will be generated indicating which circuit has the failure.

58	CFG TESTING	This must be setup as 'Non-Active. If active the system will not lockout when an I/O communications signal is lost. This setpoint should NOT be active in a live unit.
59	ACYC OFF->ON	This is the anti-cycle time delay (in seconds) from when the compressor was turned off. The compressor must wait the time frame (in seconds) in this setpoint, from last shutting off, before being allowed to start again.
60	ACYC ON->ON	This is the anti-cycle time delay (in seconds) from when the compressor was turned on. The compressor must wait the time (in seconds) in this setpoint, from last start, before being allowed to start again.
61 **	PMP CUT IN not used	
62	PMP DWN OFF	This is the suction pressure value for turning off the compressor when in the PUMP DOWN or for opening the liquid line solenoid during the PRE-PUMP down state. 'Time (sec)' field: If non-zero, then the system will bypass the pre-pump down state. This option is selected in the 'Pre-Pump Out' box in the 'Compressor Information' section under the MAG V8 tab.
63	PMP DWN DELY	Maximum time delay (in seconds) that a compressor can remain in the PUMP DOWN or PRE-PUMP down states.
64	COMP MIN RUN	This is the minimum run time (in minutes) for a compressor once it is turned on. This minimum run time can be overridden by a safety condition, however.
65	STARTER DLAY	This setpoint controls the start of a compressor's second relay. If the 'Select Value: # decimals & print char' cell is set to 'HUMD or %' then logic is: If the slide amp percentage is less than the value of this setpoint and the first relay has been on for 2 seconds or it has been on longer than the value in the safety time of this setpoint, then turn on the second relay. Else it is off. If the 'Select Value: # decimals & print char' cell is set to 'Seconds' then the setpoint's value is a time delay between the first and second relay's starts. Used for part wind (typical value of 1) and star delta (typical value of 5) starter.
66 **	OIL PUMP OFF not used	If oil pump is set up to cycle and discharge psi minus, etc.(specified in MCS-Config), this Setpoint is not used. If Discharge PSI minus Suction PSI is less than Setpoint #74 minus 10 PSI than turn on the oil pump RO. If Discharge PSI minus Suction PSI is greater than Setpoint #74, turn off the oil pump RO.
67	HI AMPS	This setpoint is a percentage of the FLA; it is used to create the high amp draw limit. The value of this setpoint is multiplied by the respective compressor's full load amps setpoint (#171 through #190) to obtain its upper limit. If the compressor's amps exceed this value for the time specified in this setpoint, then a safety trip occurs.
68	LO AMPS	This setpoint is a percentage of the FLA; it is used to create the low amp draw limit. The value of this setpoint is multiplied by the respective compressor's full load amps setpoint (#171 through #190) to obtain its lower limit. If the compressor's amps fall below this value for the time specified in this setpoint, then a safety trip occurs.
69	LOW SUCTION	If active, the system checks for low suction pressure for each running compressor. If suction pressure is less than this value for the specified period of time, a safety trip occurs. Refers to 'Suction Pressure' column in the Circuit SI screen.

70	LO SUCT UNLD	The purpose of this setpoint is to take corrective action to prevent a low suction pressure safety trip. For fixed step compressors: If a compressor has more than one step, is fully loaded, and if the suction pressure is less than the value of setpoint #77 "LOW SUCTION" plus the value of this setpoint, then one step of capacity will be turned off. For infinite step compressors: If a compressor has a suction pressure less than the value of setpoint #69 "LOW SUCTION" plus the value of this setpoint, then the compressor will be forced to unload. The circuit state will be changed to LO SUCT HOLD, and will remain in this state for a minimum of the time in setpoint #90 "SAFETY HOLD DELAY". At that time, if the suction pressure has increased greater than the value of setpoint #69 "LOW SUCTION" plus the value of setpoint #79 "LOW SUCT RELD" the compressor will return to normal control.
71	LOW SUCT RELD	Refer to setpoint #78 description.
72	UNSAFE SUCT	If active, the system checks for unsafely low suction pressure for each running compressor. If suction pressure is less than this value for the specified period of time a lockout occurs. NOTE: The time period specified should be very short (2-5 seconds). If this setpoint trips, the compressor will be sent straight to the Lockout state. Refers to 'Suction Pressure' column in the Circuit SI screen.
73	HI DISCH PSI	If active, the system checks for high discharge pressure for each running compressor. If the discharge pressure sensor reads greater than this setpoint for the specified period of time, a safety trip will occur. Refers to 'Discharge Pressure' column in the Circuit SI screen.
74	HI DISC UNLD	The purpose of this setpoint is to take corrective action to prevent a high discharge pressure safety trip. For fixed step compressors: If a compressor has more than one step, is fully loaded, and if the discharge pressure is more than the value of setpoint #73 "HI DISCH PSI" minus the value of this setpoint, then one step of capacity will be turned off. For infinite step compressors: If a compressor has a discharge pressure more than the value of setpoint #73 "HI DISCH PSI" minus the value of this setpoint, then the compressor will be forced to unload. The circuit state will be changed to HI DISC HOLD, and will remain in this state for a minimum of the time in setpoint #90 "SAFETY HOLD DELAY". At that time, if the discharge pressure has decreased below the value of setpoint #73 "HI DISCH PSI" minus the value of setpoint #75 "HI DISC RELD" the compressor will return to normal control.
75	HI DISC RELD	Refer to setpoint #74 description.
76	LO DISC SHEAT	If the calculated discharge superheat is less than this value for the specified period of time, a safety trip will occur. Also, there is an option in the Circuit Base screen to tie a Relay Output to this setpoint that will activate whenever a low discharge superheat condition occurs.
77	LO DISC PSI	If active, the system checks for low discharge pressure. If the discharge sensor reading is less than this value for the specified period of time, a safety trip occurs.
78 **	HI RETURN TEMP Not used	Only active in Mistubishi compressors. If active the system will check for high entering liquid temperature. If this temperature is greater than the value in this setpoint, the circuit state will be HI WATER HOLD.
79	HI DISCH TMP	If active, the system checks for high discharge temperature for each compressor. If the discharge temperature sensor reading is greater than this setpoint for the specified period of time, a safety trip will occur. Refers to 'Discharge Temperature' column in the Circuit SI screen.

80	DIS TMP UNLD	The purpose of this setpoint is to take corrective action to prevent a high discharge temperature safety trip. For fixed step compressors: If a compressor has more than one step, is fully loaded, and if the discharge temperature is more than the value of setpoint #79 "HI DISCH TMP" minus the value of this setpoint, then one step of capacity will be turned off. For infinite step compressors: If a compressor has a discharge temperature more than the value of setpoint #79 "HI DISCH TMP" minus the value of this setpoint, then the compressor will be forced to unload. The circuit state will be changed to HI DISC HOLD, and will remain in this state for a minimum of the time in setpoint #90 "SAFETY HOLD DELAY". At that time, if the discharge temperature has decreased below than the value of setpoint #79 "HI DISCH TMP" minus the value of setpoint #81 "DIS TMP RELD" the compressor will return to normal control.
81	DIS TMP RELD	Refer to setpoint #80 description.
82	LOW OIL DIF	If active, the system checks for low differential oil pressure. If the calculated differential oil pressure is less than this value for the specified period of time, a safety trip occurs. Refers to 'Oil Pressure' column in the Circuit SI screen.
83	UNSAFE OIL	If active, the system checks for unsafe differential oil pressure. If the calculated differential oil pressure is less than this value for the specified period of time, a lockout occurs. NOTE: The time period specified should be very short (2-5 seconds). If this setpoint trips, the compressor will be sent straight to the Lockout state. Refers to 'Oil Pressure' column in the Circuit SI screen.
84	HI OIL SEAL	If the oil seal or oil cooler temperature exceeds the value of this setpoint for the time specified, a safety trip occurs. Refers to 'Oil Seal Temp' column in Circuit SI screen.
85	HI OIL TEMP	If active, the system checks for high oil temperature. The sensor can be either an analog or digital input. If the oil temperature sensor reading is ON (Digital) or exceeding the temperature value of this setpoint (Analog) for the specified period of time, a safety trip occurs. Refers to 'Oil Temp' column in the Circuit SI screen.
86	MOTOR FAULT	If active, the system checks for high motor temperature. The sensor can be either an analog or digital input. If the motor temperature sensor reading is ON (Digital) or exceeding the temperature value of this setpoint (Analog) for the specified period of time, a safety trip occurs. Refers to 'Motor Temp' column in the Circuit SI screen.
87	NO CMP PROOF	If active, when the compressor is called to be on by the controller, the system will check for a digital input to indicate that the compressor is indeed running. If the controller calls for a compressor to turn on and no proof is given in the specified period of time, a safety trip occurs. Refers to 'Comp Proof' column in the Circuit Base screen
88	DIRTY FILTER	If discharge pressure minus oil filter pressure is greater than this value for the time specified, a safety trip occurs.
89 **	HIGH SUMP TEMP not used	If active, and sump temperature is above the value of this setpoint for the time specified, a HIGH SUMP TEMP alarm is generated and the unit is locked out.
90	SAFETY HOLD DELAY (only used with variable type of compressors)	Time in seconds that the circuit will remain in a hold state after the condition that caused it has returned to normal. The circuit can be holding for the following reasons: Low suction pressure Low refrigerant temperature High discharge pressure High discharge temperature High amperage
91 **	PUMP FREEZE PROTECTION not used	

92	LEAD COMP	Enables the user to specify the lead compressor. The value of this setpoint will indicate the lead compressor. If zero, then auto rotation is enabled. If the 'Time (sec)' field is non-zero the compressor with the least amount of run time will become the lead compressor upon rotation.
93	COMP ROTATION	Specifies the number of days between rotations (setpoint #92 must be set to zero to enable auto rotation). If zero, then rotation will occur with every cycle.
94 **	LLS#2 ON not used	This setpoint is used to control a second liquid line solenoid. When the capacity wanted is greater than this value (can either be number of steps for Fixed Step compressors, or percentage of full load amps for Infinite Step compressors) for the number of seconds in the 'Time (sec)' field, the second liquid line solenoid will open. When the compressor capacity below this value for the number of seconds in Delay Between Trips Field the second liquid line will be turned off. 'Time (sec)' field: The delay in seconds before the solenoid will be turned on. If zero, then there will be no delay. Delay Between Trips Field: The delay in seconds before turning this solenoid off. If zero, then an offset of 20 seconds will be used.
95 **	LLS#3 ON not used	This setpoint is used to control a third liquid line solenoid. When the capacity wanted is greater than this value (can either be number of steps for Fixed Step compressors, or percentage of full load amps for Infinite Step compressors) for the number of seconds in the 'Time (sec)' field, the third liquid line solenoid will open. When the compressor capacity below this value for the number of seconds in Delay Between Trips Field the third liquid line will be turned off. 'Time (sec)' field: The delay in seconds before the solenoid will be turned on. If zero, then there will be no delay. Delay Between Trips Field: The delay in seconds before turning this solenoid off. If zero, then an offset of 20 seconds will be used.
96	FREEZE	If active, the system will compare the leaving temperature to this setpoint. If it is less than this value for the specified period of time, a safety trip occurs.
97	NO STOP	This setpoint is used to ensure that a compressor is actually off when the controller calls for it to be off. This setpoint contains a percentage of the FLA for setpoints #171-#190. If the compressor amperage is greater than this percentage of the FLA setpoint for the specified period of time, signaling that the compressor is still running, then the entire system is locked out and a NO STOP alarm is generated. If a Control Power relay is specified, then it will be turned off when this safety trips.
98 **	OIL INJ TEMP DIFF not used	This is a temperature differential subtracted from setpoint #8 to control the oil injection relay. When discharge temperature is above this differential, then oil injection is turned on. If inactive then value will be 5.6° F (2.8° C).
99 **	OIL TEMP DIFF not used	This is a temperature differential used in controlling the oil heater and second liquid line solenoid. If inactive then value will be set to 5° F.
100	OIL FLOAT	If active, the system checks for an oil float digital input. It must be ON for the period of time specified in the setpoint before this setpoint will trip.
101	Lost Leg Alm	If active, a check for a lost leg (lost current flow) on a part winding starter is added. A current sensor will be placed on only one of the legs; it must be set up to be multiplied by 2 in MCS-Config (select CT-### x2 as the sensor in the SI screen). If current flow to the leg with the sensor is lost, a low amp alarm will be generated. If the sensor is reading more than the wanted FLA times the value of this setpoint for the specified period of time, then a high amp alarm is generated.
102 **	LOW AMBIENT OFF not used	Compressors with a low SI Off sensor will be disabled when the sensor is below this setpoint.
103 **	HI AMBIENT OFF not used	Compressors with a high SI Off sensor will be disabled when the sensor is above this setpoint.
104 **	UNLOADED % not used	Used if a slide open percentage sensor is present. When this sensor is reading less than the value of this setpoint, then the slide is considered closed.

105 **	OIL HEATER ON not used	The oil heater will be turned on if the oil temperature is less than the value of this setpoint. It will be turned off if the oil temperature is greater than the value of this setpoint plus 5.0° Fahrenheit. 'Time (sec)' field: If zero, then the calculated oil temp will be the saturated suction temperature plus the value of the setpoint. Else it will be the value of this setpoint.
106 **	OIL COOLER ON not used	The oil cooler will be turned on if the oil seal temperature is greater than the value of this setpoint. It will be turned off if the oil seal temperature is less than the value of this setpoint minus 5.0° Fahrenheit.
107 **	UNLOADED OFF not used	If active, the system is fully unloaded, and the control temperature is greater than this value, then the capacity state will be set to holding.
108	HP OVERHEAT	This setpoint is only used when the heat pump option has been selected in the 'Unit Type' box in the 'General Information' section under the MAG V8 tab. It is used to protect against a heat pump with unloaders (or variable speed) from overheating. When this setpoint is active and the leaving temperature sensor is greater than this setpoint minus 3.0° Fahrenheit, then the compressor will enter HIGH TEMP UNLOAD state. The temperature must drop to less than this setpoint minus 4.5° Fahrenheit before the system will move to the holding state.
109	SftyUnld Del	The time delay in seconds between compressor capacity adjustments when safety unloading.
110	VFD Sfty Adj	The VFD percentage adjustment to be made after every amount of time in setpoint #153 "SftyUnld Del" when safety unloading.
111	LO REF TMP	If active, the system checks for low refrigerant temperature. If the refrigerant temperature is less than the value of this setpoint for the specified period of time, a safety trip occurs.
112	LO REF UNLD	The purpose of this setpoint is to take preventative action before a low refrigerant temperature safety trip. The compressor will unload when the refrigerant temperature is less than the value of the setpoint #111 "LO REF TMP" plus this setpoint. The compressor state will be changed to LO TMP UNLOAD. The compressor will remain in this state until the refrigerant temperature is above the value of setpoint #111 "LO REF TMP" plus twice the value of this setpoint. The compressor state change to LO TMP HOLD.
113	CRANK CASE HEAT	If active and a crank case heater proof has been specified for a circuit, if the digital input, crank case heater proof, is on for the time specified a compressor safety will be generated.
114	DHH WAIT	The system will wait the number of seconds contained in this set point if the compressor is in dehumidification heat mode and the compressor is ready to be defrosted before the defrost cycle begins.
115 **	ROTATE EVAP	If active, then the Relay Outputs must have a second liquid line solenoid and 2 hot gas solenoids. Not used with Reverse Cycle type of defrost. Must be active and a value = 1 If active and the value is 0 then when the system is in the dehumidification mode the evaporators will be rotated during the defrost cycle. Refer to dehumidification defrost with rotation.
116 **	MAX IN DEHUM not used	This is the maximum number of evaporator solenoids that can be on when the system is in the dehumidify mode.
117	DefConvType	Indicates the types of defrost. If active and value is a 1 then conventional defrost will be used. Else Defrost on the Fly type of defrost will be used.
118	DEF HI TEMP	Set points #118, #119 & #120 work as a group. If the entering temperature is less than set point #118 but greater than set point #121, the values in #118, #119 & #120 will be used to determine if a defrost cycle is required. 'Target' - then setpoint high zone column is used as the ambient disable temperature for rotating coil defrost. Otherwise if is not configured as "Target" type the old logic value as the ambient disable point for rotating coil defrost is used.

119	DEF HI APPR	The calculated defrost approach temperature must be greater than the value of this set point for the system to enter a high defrost cycle.
120	DEF HI TIME	This set point contains the time expressed in minutes that a compressor will remain in a high defrost cycle. Expressed as minutes. 'Target' - then manual defrost time delay is based on the enter temp compared to setpoint #118, 121, and 124 and uses the values in the high zone column from setpoint #120, 123, or 126 as the defrost time delay.
121	DEF MED TEMP	Set points #121, #122 & #123 work as a group. If the entering temperature is less than set point #121 but greater than set point #123, the values in #121, #122 & #123 will be used to determine if a defrost cycle is required.
122	DEF MED APPR	The calculated defrost approach temperature must be greater than the value of this set point for the system to enter a medium defrost cycle.
123	DEF MED TIME	This set point contains the time expressed in minutes that a compressor will remain in a medium defrost cycle. Expressed as minutes.
124	DEF LO TEMP	Set points #124, #125 & #126 work as a group. If the entering temperature is less than set point #121, the values in #124, #125 & #126 will be used to determine if a defrost cycle is required..
125	DEF LO APPR	The calculated defrost approach temperature must be greater than the value of this set point for the system to enter a low defrost cycle.
126	DEF LO TIME	This set point contains the time expressed in minutes that a compressor will remain in a low defrost cycle. Expressed as minutes.
127	DEF DEH APPR	If the dehumidification enable indicator is on, the calculated defrost approach temperature must greater than the value of this set point for the system to enter a defrost cycle.
128	DEF DEH TIME	This set point contains the time expressed in minutes that a compressor will remain in a dehumidification enable defrost cycle. Expressed as minutes.
129	DEF DEH 2ND	This set point contains the percent of the time that a compressor will remain in a dehumidification enable defrost cycle for the second evaporator if set point 115, ROTATE EVAP, is active and equal to 0.
130	DefMinAccTime	This is the minimum accumulated run that a compressor must be on before a defrost cycle can be initiated. Expressed as minutes.
131	AprTypAdjDly	Time in minutes that the system waits, after a defrost, before determining what defrost valves to use.
132	DEFDRIP DWN	This setpoint contains the time expressed in minutes, that the system will remain in a drip down state for each evaporator defrost. For reverse cycle defrost types, this setpoint must be active and a value of zero.
133	DEF MAX EVAP	This set point contains the maximum number of circuits that can be in defrost at any one time.
134	EVAP Rotation	If this set point is active and its value is greater than zero then the evaporators will be rotated when the number of evaporator relays that are ON is less than the number available. The value which is expressed in minutes is the time between rotations
135	HTGDTD MAIN	When the circuit is in a defrost cycle and the time has not exceeded the value of this set point, the hot gas main is turned off and the hot gas bypass is turned on. When the time exceeds this value, the hot gas main is turned on; refer to set point #136 to determine the status of the hot gas bypass.
136	HGDBP&BLEED	When the circuit is in a defrost cycle and the time has exceeded the value in set point #135, HTGDTD MAIN; if this set point contains a zero the hot gas bypass will be turned off, else it will be turned on.
137	ApprONdly	This is the time expressed in seconds that the evaporator temperature must be greater than the defrost trigger temperature before a defrost cycle will be checked to determine if a defrost cycle is required.

138	DEF CMP RTIM	This is the minimum time that a compressor must be on before a defrost cycle can be initiated. Expressed as minutes. Note, time in set point #130, accumulated run must be met and the compressor must be on for the time specified in this set point before a defrost cycle is initiated.
139	DEF Min PSI	When a compressor is in a defrost start state the defrost cycle will not begin until the discharge pressure is less or equal to the value in this set point.
140	DEF COND ADJ	When a compressor is in defrost, the value of this set point is added to the condenser set points.
141	DEF PDWN TIM	This is the maximum time that a compressor will remain in the defrost pump down state. Expressed in seconds.
142	DEF PDWN PSI	A compressor will remain in the defrost pump down state until the suction pressure decreases by the value of this set point. Also refer to set point #143
143	DEF TERMIN T	When a compressor is in a defrost mode and the evaporator suction temperature rises above the value in this set point, the defrost cycle will be terminated.
144	DEF TERMIN P	When a compressor is in a defrost mode and the discharge pressure drops below the value in this set point, the defrost cycle will be terminated.
145	DEF TIME DLY	This is the time delay between defrost cycles expressed as minutes. Note this was a fixed time. Not used if set point #120, #123, #126 high zone has values.
146 **	DEF AIR HGAS not used	Set point is used to indicate when the defrost air option is used and a hot gas defrost as backup is required. If this set point is active a message will be generated indicating which circuit required the hot gas defrost.
147 **	DEF AIR TIME not used	Value expressed in minutes is the maximum time that a circuit will be in air defrosts cycle.
148 **	DEF AIR BLEED not used	Time expressed in minutes that the bleed solenoid will be on when a normal air defrost cycle begins. During this time the hot gas main solenoid will be off. Once this time has passed the bleed solenoid will be turned off and hot gas main solenoid will be turned on.
149 **	DEF AIR ALARM not used	If this set point is active, a defrost alarm messages will be generated.
150 **	EVAP FAN WAIT not used	After defrost time to keep the system off.
151	LIQUID LINE CTL	Only used with a variable type of compressor to control the liquid injection solenoid.
152	ADJUST APPROACH	If this set point is active and the number of steps on is greater than the minimum, then all approach defrost set points will be adjusted by this set point. This set point is expressed as a percentage. The amount of adjustment is calculated by taking the number of steps that are on greater than the minimum number and dividing this by the number of available steps. This is then multiplied by the value of this set point and it is subtracted from the approach set points. The actual value of the set point will be changed.
153	HOT GAS ON	If there is a modulating hot gas valve, this valve will be modulated when the control voltage or temperature is below this value.
154 **	PUMP DELAY not used	Time in seconds to keep the chilled water pump running after the last compressor has been turned off to ensure the chiller barrel does not freeze.
155	HI SI OFF	If active, and a High SI OFF sensor is specified (sensor can be an analog or digital input, and is specified in the Circuit SI screen for each compressor). If the High SI Off sensor reading ON (Digital) or the temperature rises above the value of this setpoint (Analog) for the specified period of time, the circuit will be disabled. If a digital input, the circuit will be enabled once the sensor is off. If an analog input, the circuit will be enabled once the sensor is less than the value of this setpoint minus the value in the 'Time (sec)' field.

156	LOW SI OFF	If active, and a LOW SI OFF sensor is specified (sensor can be an analog or digital input, and is specified in the Circuit SI screen for each compressor). If the LOW SI Off sensor reading ON (Digital) or temperature drops below the value of this setpoint (Analog) for the specified period of time, the circuit will be disabled. If a digital input, the circuit will be enabled once the sensor is off. If an analog input, the circuit will be enabled once the sensor is rises above the value of this setpoint plus the value in the 'Time (sec)' field.
157 **	COND COMP HIGH not used	If active, this set point contains the pressure difference that will be used to determine if a compressor has reached a critical condition when another compressor is in a start up. If inactive, a value of 50.0 PSI will be used. A critical condition is determined by subtracting this value from set point #70, HI DISCH PSI. If the discharge pressure is greater then this pressure will be used to control the fans.
158	PHASE LOSS	If active and the phase loss digital input is ON for the specified period of time, a safety trip occurs. The system will attempt to restart after waiting the number of minutes contained in the 'Safety Down Time' field of this setpoint.
159	PWR OFF TIME	If the system is off for a time greater than 2 hours then the system state will be 'POWER LOSS DELAY' for the time contained in this setpoint , the time is expressed in hours.
160	LO SHT DXcoil	If the calculated superheat remains below this value for the time specified, the system will generate a LOW SHT DX alarm. This is the superheat calculated at the dx coil.
161	HI SHT DXcoil	If the calculated superheat remains above this value for the time specified, the system will generate a HIGH SHT DX alarm. This is the superheat calculated at the dx coil.
162	LHI SUPERHEAT	If the calculated superheat remains above this value for the time specified, the system will generate a HIGH SUPERHEAT alarm. This is the superheat calculated at the compressor.
163	HiRefLevel	This setpoint has two functions. If active, the system checks for high refrigeration level. If the refrigeration level sensor is greater than this value for the specified period of time, a safety trip occurs. If active, system has EXV valve control based on refrigerant level, and the refrigerant level is greater than this value, then the EXV valve adjustment will be set to the value in setpoint #13 "EXV COURSE" * (-3). Refers to 'Refrig Level' column in the Circuit SI screen
164	LoRefLvlTarg	If setpoint #76 "LO DiscSPRHT" is active and it has reached one third of its safety time, then setpoint #9 "REF LVL TARG" will be set to the value of this setpoint,
165	PULSE DELAY	Used with infinite capacity screws. The number of seconds between load or unload pulses (Usually between 3 and 5. Allows load change to be checked before next pulse and eliminates oil foaming when unloading too fast). 'Time (sec)' field: If used, this is the fast unloading state time delay. This option is selected in in the 'Fast Unload Delay' box in the 'Compressor Information' section under the MAG V8 tab.If non-zero, and when the compressor's amp draw is more than twice the value of setpoint #192 "AMP DB LO" away from the wanted FLA, then set the delay between pulses to zero.
166	REVERSE CYCLE COMP OFF TIME WHEN DEFROST START	Add logic for Reverse Cycle defrost to have adjustable time delay for turning off the compressors when first entering into, and coming out of, the defrosting coil state. If this setpoint is active its value is used as the delay, otherwise 5 seconds is still used. This change was made to help the reversing valve to switch positions before and after defrost was completed. The scroll compressors do not need this extra time but reciprocating compressors do need it.

167	PUMP FAILURE (NO FLOW)	If active, flow is lost, and only one pump is present, then the system will be locked out. If the system has two pumps and flow is lost, then the backup pump will start and the lead pump will be locked out. If the second pump is running and flow is lost again then the entire system will be locked out. A lock out reset will be required to restart the system or to reactivate a locked out pump. If inactive, and the flow is lost, the system will move to the OFF- NO EVAP FLOW state. When flow is returned the system will automatically restart.
168	UNLOAD DELAY	This is the time delay before the system will begin to unload a circuit due to a pending safety condition. This includes: high discharge PSI, high discharge temperature, low or high amps, or low suction PSI.
169	LO SUCT SHEAT	This set point contains the value that indicates a low suction SUPERHEAT condition. If the calculated suction SUPERHEAT is less than this value, the low suction SUPERHEAT timer will be set to 120 seconds. This will keep the low suction SUPERHEAT RO on for that period of time. (This can be used as a warning only or the user may wire through the low suction superheat relay to solve the problem.) . Note, during the first 5 minutes that compressor has been running, the safety time is increased to 3 times the safety time of this set point.
170	SERVICE MODE	If non-zero, then a compressor being disabled by the pump down switch will be continue to run until its suction pressure is zero. The compressor will be turned on to perform the pump down the number of times indicated in this setpoint. This is in preparation for service to be performed on the compressor.
171	FLA COMP#1	Full Load Amps for compressor #1. This is the amps at design suction and discharge pressures referenced in the MCS-Config RO screen. This value is used to calculate the high and the low amperage safety limits. Refer to setpoints #75 and #76. For screw compressors: The amp draw when the compressor is fully loaded. This value is used to calculate the Full Load Amps Percentage (FLA %), which is used to control loading and unloading the slide valve.
172	FLA COMP#2	Full Load Amps for compressor #2. Refer to setpoint #171.
173	FLA COMP#3	Full Load Amps for compressor #3. Refer to setpoint #171.
174	FLA COMP#4	Full Load Amps for compressor #4. Refer to setpoint #171.
175	FLA COMP#5	Full Load Amps for compressor #5. Refer to setpoint #171.
176	FLA COMP#6	Full Load Amps for compressor #6. Refer to setpoint #171.
177	FLA COMP#7	Full Load Amps for compressor #7. Refer to setpoint #171.
178	FLA COMP#8	Full Load Amps for compressor #8. Refer to setpoint #171.
179	FLA COMP#9	Full Load Amps for compressor #9. Refer to setpoint #171.
180	FLA COMP#10	Full Load Amps for compressor #10. Refer to setpoint #171.
181	FLA COMP#11	Full Load Amps for compressor #11. Refer to setpoint #171.
182	FLA COMP#12	Full Load Amps for compressor #12. Refer to setpoint #171.
183	FLA COMP#13	Full Load Amps for compressor #13. Refer to setpoint #171.
184	FLA COMP#14	Full Load Amps for compressor #14. Refer to setpoint #171.
185	FLA COMP#15	Full Load Amps for compressor #15. Refer to setpoint #171.
186	FLA COMP#16	Full Load Amps for compressor #16. Refer to setpoint #171.
187	FLA COMP#17	Full Load Amps for compressor #17. Refer to setpoint #171.
188	FLA COMP#18	Full Load Amps for compressor #18. Refer to setpoint #171.
189	FLA COMP#19	Full Load Amps for compressor #19. Refer to setpoint #171.
190	FLA COMP#20	Full Load Amps for compressor #20. Refer to setpoint #171.

191	AMP DB HI	Used only with screw and centrifugal compressors. If the set point type is “humidity” then the upper dead band is value times the FLA for that circuit else the value is the upper dead band limit of the FLA. If the amps are within the dead band, the slide valve will not be moved. If controlled by Slide Position, instead of FLA, this Setpoint will not be used.
192	AMP DB LO	Used only with screw and centrifugal compressors. . If the set point type is “humidity” then the lower dead band is value times the FLA for that circuit else the value is the lower dead band limit of the FLA. If the amps are within the dead band, the slide valve will not be moved. If controlled by Slide Position, instead of FLA, this Setpoint will not be used.
193	MOP TARG PSI	If active, maximum operating pressure (MOP) control will be added to the EXV control logic. This value will be the MOP suction pressure target.
194	MOP PSI ZONE	Added to and subtracted from setpoint #199 to develop the upper and lower limits of the MOP control zone.
193	MOP TARG PSI	If active, maximum operating pressure (MOP) control will be added to the EXV control logic. This value will be the MOP suction pressure target.
194	MOP PSI ZONE	Added to and subtracted from setpoint #199 to develop the upper and lower limits of the MOP control zone.
195	MOP ADJ % TME	The adjustment value by which the EXV valve will close each time the MOP logic calls for it to maintain the suction pressure target. This adjustment will be made each time after the delay in the ‘Time (sec)’ field has expired.
196	MDP MIN OIL DIFF	If active, MDP logic will be added to EXV control. If the oil differential pressure is less than the value of this setpoint following compressor start up during the time specified in the Sec to Ignore Safety field, then the MDP function is active and will close the EXV valve to restore the oil differential pressure. However, the EXV will not be allowed to go into the MDP logic unless the suction pressure is less than setpoint #69 “LOW SUCTION” plus twice the value of setpoint #71 “LOW SUCT RELD”. The MDP logic will be exited and go to EXV HOLDING when the suction pressure is less than the setpoint #69 “LOW SUCTION” plus the value of setpoint #71 “LOW SUCT RELD”. The ‘Sec to Ignore Safety’ cell contains the time that the MDP will be active after a compressor is started. The “Time (sec)’ field’ cell contains the offset to exit the MDP control. The ‘Safety Down Time’ contains the percentage to close the EXV valve.
197 **	DELTA TEMP EVP not used	If active, the system will check the temperature differential before additional capacity is enabled. If the difference between entering and leaving temperature is greater than the value of this setpoint for the amount of time in the ‘Time (sec)’ field, then no additional capacity will be allowed.
198	HiSuctSheat	If active, the system will check for high suction superheat. If the suction superheat is greater than the value of this setpoint for the specified period of time, an alarm will be generated and a safety trip occurs.
199- 201	not used	
202	NO OIL FLOW	If active and there is an Oil Flow sensor specified in the ‘Oil Flow Switch’ cell of the Circuit SI screen, then the system will test for oil flow. If the No Oil Flow sensor reading is OFF (Digital) or falls below the value of this setpoint (Analog) for the specified period of time, then a safety trip occurs.
203	SAT EVAP ADJ	This set point contains the temperature adjustment that is made to suction temperature (converted from suction PSI) when calculating the evaporator approach value.
204	SPARE	Not used.

205	STAGE CUT OUT	Offset used in calculating the cut out value. Subtracted from the stage cut in set points #206 through #229
206	STAGE 1 CUT IN	STAGE 1 cut in, set point value contains the value when this stage is turned on.
207	STAGE 2 CUT IN	STAGE 2 cut in, set point value contains the value when this stage is turned on.
208	STAGE 3 CUT IN	STAGE 3 cut in, set point value contains the value when this stage is turned on.
209	STAGE 4 CUT IN	STAGE 4 cut in, set point value contains the value when this stage is turned on.
210	STAGE 5 CUT IN	STAGE 5 cut in, set point value contains the value when this stage is turned on.
211	STAGE 6 CUT IN	STAGE 6 cut in, set point value contains the value when this stage is turned on.
212	STAGE 7 CUT IN	STAGE 7 cut in, set point value contains the value when this stage is turned on.
213	STAGE 8 CUT IN	STAGE 8 cut in, set point value contains the value when this stage is turned on.
214	STAGE 9 CUT IN	STAGE 9 cut in, set point value contains the value when this stage is turned on.
215	STAGE 10 CUT IN	STAGE 10 cut in, set point value contains the value when this stage is turned on.
216	STAGE 11 CUT IN	STAGE 11 cut in, set point value contains the value when this stage is turned on.
217	STAGE 12 CUT IN	STAGE 12 cut in, set point value contains the value when this stage is turned on.
218	STAGE 13 CUT IN	STAGE 13 cut in, set point value contains the value when this stage is turned on.
219	STAGE 14 CUT IN	STAGE 14 cut in, set point value contains the value when this stage is turned on.
220	STAGE 15 CUT IN	STAGE 15 cut in, set point value contains the value when this stage is turned on.
221	STAGE 16 CUT IN	STAGE 16 cut in, set point value contains the value when this stage is turned on.
222	STAGE 17 CUT IN	STAGE 17 cut in, set point value contains the value when this stage is turned on.
223	STAGE 18 CUT IN	STAGE 18 cut in, set point value contains the value when this stage is turned on.
224	STAGE 19 CUT IN	STAGE 19 cut in, set point value contains the value when this stage is turned on.
225	STAGE 20 CUT IN	STAGE 20 cut in, set point value contains the value when this stage is turned on.
226	STAGE 21 CUT IN	STAGE 21 cut in, set point value contains the value when this stage is turned on.
227	STAGE 22 CUT IN	STAGE 22 cut in, set point value contains the value when this stage is turned on.
228	STAGE 23 CUT IN	STAGE 23 cut in, set point value contains the value when this stage is turned on.
229	STAGE 24 CUT IN	STAGE 24 cut in, set point value contains the value when this stage is turned on.
230	Not Available	This set point cannot be used it MUST be INACTIVE! This forces all EXV fine tune type set points to be inactive; therefore, the default settings will be used.
231-235	not used	
236	AirDefHiTemp	Set points #236, #237 & #238 work as a group. If the entering temperature is less than set point #236 but greater than set point #239, the values in #236, #237 & #238 will be used to determine if a defrost cycle is required. If the evaporator entering temp SI is greater than this value, air defrost will be disabled.
237	AirDefHiAppr	The calculated defrost approach temperature must be greater than the value of this set point for the system to enter a high defrost cycle.
238	AirDefHiTime	This set point contains the time expressed in minutes that a compressor will remain in a high defrost cycle. Expressed as minutes.
239	AirDefMdTemp	Set points #239, #240 & #241 work as a group. If the entering temperature is less than set point #239 but greater than set point #242, the values in #239, #240 & #241 will be used to determine if a defrost cycle is required.
240	AirDefMdAppr	The calculated defrost approach temperature must be greater than the value of this set point for the system to enter a high defrost cycle.
241	AirDefMdTime	This set point contains the time expressed in minutes that a compressor will remain in a high defrost cycle. Expressed as minutes.

242	AirDefLoTemp	Set points #236, #237 & #238 work as a group. If the entering temperature is less than set point #242 but greater than the value of set point #242 – the Low Zone value, the values in #242, #243 & #244 will be used to determine if a defrost cycle is required. Low Zone: Contains the value to be subtracted to the value of this setpoint, if the evaporator entering temp SI is below this calculation, air defrost is disabled.
243	AirDefLoAppr	The calculated defrost approach temperature must be greater than the value of this set point for the system to enter a high defrost cycle.
244	AirDefLoTime	This set point contains the time expressed in minutes that a compressor will remain in a high defrost cycle. Expressed as minutes.
245	AirDefCmpDly	Contains the amount of time, expressed as minutes, that a compressor calling for defrost, will be delayed from shutting off so that the logic can bring another compressor up to capacity to ensure refrigeration is maintained. This still applies, even if all compressors are on and fully loaded.
246	AirDefTrgrDly	This is the time expressed in seconds that the evaporator temperature must be greater than the defrost trigger temperature before a defrost cycle will be checked to determine if a defrost cycle is required.
247	Reheat Offset Off	Voltage must be greater than this value to allow reheat relays to be turned on.
248	Reheat Stage 1	Voltage above this value will allow 1 stage of reheat to be turned on.
249	Reheat Stage 2	Voltage above this value will allow 2 stage of reheat to be turned on.
250	Reheat Stage 3	Voltage above this value will allow 3 stage of reheat to be turned on.
251	Reheat Stage 4	Voltage above this value will allow 4 stage of reheat to be turned on.
252	Reheat Stage 5	Voltage above this value will allow 5 stage of reheat to be turned on.
253	Reheat Stage 6	Voltage above this value will allow 6 stage of reheat to be turned on.
254	Low Suction Unloads	If active the number of low suction unloads will be tracked. If the number of unloads is greater than the value with in the time specified in the safety time cell then the circuit will be locked off.
255	Split Scroll Staging	If active and compressor type is a scroll with split staging, PETRA special staging: Value contains the number of compressor steps available for staging. Safety Time is the delay between step adjustments.

Chapter - 33. Magnum Alarms and Safeties

33.1. Introduction

There are three types of alarms that are generated by the Magnum control logic:

- **Information only alarms,**
- **Magnum system alarms and**
- **Chiller set point safety alarms.**

All of the alarms have the same format. The alarm is identified and it is date time stamped. Alarms can be viewed from the Magnum by pressing the ALARM STATUS (4) key or from the MCS-Connect program.

33.2. Information only Alarms

33.2.1 System Generated Alarms

The following alarms are generated to provide information; they will not cause a change in the control algorithm such as a lock out condition or a relay output being forced off.

- **POWER FAILED**
- **POWER RETURNED**
- **COMPUTER RESET**
- **LCD FAILURE**
- **HW DATE INVALID**
- **HW TIME INVALID**
- **SW DATE INVALID**
- **SW TIME INVALID**
- **RAM INTEGRITY**
- **WATCHDOG RESET**

33.2.2 Alarms As A Result Of Individual Action

The following alarms indicate that an individual took action:

- **ALARMS CLEARED**
- **STPT CHANGED**
- **RO MANUAL**
- **AO MANUAL**
- **SI MANUAL**
- **POINT INFO CLEAR**
- **CLOCK SET**
- **CFG DOWNLOADED**

33.2.3 Alarms Generated By The Control Algorithm

The following alarms indicate that the control algorithm took action:

- **ROTATED LEAD**
- **DAYLIGHT SAVINGS**

33.3. Magnum System Alarms

33.3.1 Alarms Are Generated By The Magnum Control Algorithm:

33.3.1.1. **Configuration Problem Alarms**

These alarms indicate a problem with the configuration file that has been loaded into the system. The system is not operational, a configuration must be transmitted to the unit from MCS-Connect or the config chip must be replaced with a valid one.

- INVALID CONFIG. (Check if sums are incorrect)
- INVALID CFG VER (version number of the configurator is invalid)
- INVALID CFG TYPE (the type does not agree with software, chiller software with a home unit configuration)

33.3.1.2. Mcs Local Network Problem Alarms

These alarms indicate problems with the MCS local network, the system can be accessed but the system is in a lock out state, LOST I/O.

- MCS-I/O 1 LOST
- MCS-I/O 2 LOST
- MCS-I/O 3 LOST
- LOST IO SHUTDOWN

33.3.1.3. Key Sensors Problem Alarms

This alarm indicate a problem with a key sensor, it is either shorted or open. The alarm will contain ALARM followed by the 8-character name of the sensor.

The following sensors related to the entire system are tested:

- Leaving liquid, if failed: lock out the chiller system
- Returning liquid, if failed: alarm only no lock out
- Ambient temperature, if failed: alarm only no lock out

The following circuit sensors are tested. If they fail that circuit only is locked out.

- Suction pressure and temperature
- Discharge pressure and temperature
- Oil pressure and temperature
- Motor temperature (if it is an analog input device)

33.3.1.4. EMERGENCY STOP Alarm

This alarm indicates that the emergency stop switch has been turned on. The system can be accessed but the entire system is in a lock out state.

- **EMERGENCY STOP**

33.4. Set Point Safety Alarms

33.4.1 Introduction

The Magnum chiller algorithm incorporates a number of safety checks to ensure that the various components that make up the chiller package are not damaged. These types of safeties are based upon set points. When a safety trips for the first time, the compressor will be set to "SAFETY TRIPPED" state. The compressor will remain in "SAFETY TRIPPED" state for ten minutes and then move to the "CMP IS OFF" state where the compressor will be allowed to run if required. If the same safety occurs again within two hours of the first trip, the compressor will be set to "CMP LOCKED OUT" state, which requires a manual reset to restart the compressor. In this matter the Magnum attempts to take corrective action to protect the compressors but avoid nuisance trips.

The time in the safety state and the time between safeties are specified in the individual set points. This enables the times to be unique for each lock out set point.

33.4.2 **Sensor Inputs used In Conjunction with Magnum Set Point Safeties:**

Suction Pressure

Read the suction pressure. (Optional digital input)

Discharge Pressure

Read the discharge pressure. (Optional digital input)

Oil Pressure

Read the oil pressure (optional digital input)

Oil Differential Pressure

Calculated value of the oil pressure as follows:

Fixed step compressors, oil psi minus suction psi

Screws with oil pump, Oil psi minus discharge psi

Screws without oil pump, discharge psi minus suction psi

Oil Temperature

Indicates that a high oil temperature condition. This can be either a temperature sensor or a digital input.

Discharge Temperature

Indicates that a high discharge temperature condition. This can be either a temperature sensor or a digital input.

Motor Temperature

Indicates that a high motor temperature condition. This can be either a temperature sensor or a digital input.

Motor Amps

Sensor input that measures AMP draw of the compressor. (Optional digital input)

Motor Fault

If the high motor temperature input rises above the value of the setpoint or the digital input turns ON for the time specified in the 'Time (sec)' field, the circuit will be Locked Out and a HIGH MOTOR TEMPERATURE or MOTOR FAULT alarm generated. Refer to setpoint #86.

Liquid Temperature

Temperature sensor that can be used to detect a freeze condition

Compress Proof

A digital input that when on indicates that a compressor is running.

Flow Switch

A digital input that indicates that flow through the chiller barrel exists. There can be one switch per chiller or one for each circuit.

33.4.3 Set Point Safeties

For a safety to be interrogated, both the associated sensor input and the lockout set point must be active. If a safety trips, the alarm name will consist of the set point name plus additional identification such as point number or circuit number if applicable.

The system exercises "smart" safety testing in the following manner:

If a safety applies to a circuit and it is an active lockout type of a set point, the first time this safety trips an alarm will be generated and the circuit will be shut down and placed in a safety state. The system will attempt to reactivate this circuit after waiting the length of time specified in this set point, safety down time. If successful the system will continue to run. If the same safety trips the time specified in the lockout delay time, the circuit will be locked off and a manual intervention is required. If the lockout delay time is set to zero, the system will generate a lockout condition the first time that the safety occurs.

The time in the safety state and the time between safeties are specified in the individual set points. This enables the times to be unique for each lock out set point.

MOST SAFETIES ARE CHECKED ONLY IF THE COMPRESSOR IS RUNNING, IF THE SAFETY IS ALWAYS CHECKED IT WILL BE SO NOTED.

The following are a list of safeties that are incorporated in the standard chiller algorithm control. These safeties are checked every second. Note, for a multiple circuit system, each circuit is tested individually. If a safety condition exists, action will be taken with that circuit only, other circuits will continue to function.

Freeze Protection (SAFETY IS ALWAYS CHECKED)

If the leaving liquid temperature drops below the set point value the system, and all circuits, will enter a lockout state and a freeze notification alarm will be generated. You have the option of one freeze protect for the package or individual freeze protections by circuit. This is selected in the MCS-Config program.

No Flow Protection

If the flow switch is for the chiller system, then the entire system will be shut down with the LOCK OUT state if set point 167, PUMP FAILURE, is an active lockout type of set point. If the set point is inactive, the system will determine if there is a second pump, if so it will be started. Else, the system will be shut down and automatically restarted when the flow switch is on, indicating that there is flow. If the flow switch is for the individual circuit, then that circuit will be locked out.

Phase Loss Protection

Phase loss, as indicated by the phase loss monitor, will result in the system and all circuits being locked off and a phase loss notification alarm will be generated. Refer to set point is #158.

Emergency Stop

Emergency stop, as indicated by the emergency stop switch, will result in the system and all circuits being locked off and an emergency stop notification alarm will be generated. No set point is required.

Low Differential Oil Pressure

This safety is designed to meet the compressor manufacturer requirements on oil pressure. For the first 5 (60 seconds if setup as Hitachi screw compressors) seconds following a compressor start this safety is NOT checked. For the next 30 seconds, if the oil differential pressure drops below $\frac{1}{2}$ of the value of the set point or the digital input turns ON and it remains there for the time specified in the safety time of that set point, the compressor will be locked out and a low oil alarm generated. After this time period, if the oil differential pressure drops below the value of the set point and it remains there for the time specified in the safety time, the compressor will be locked out (as described in section 'Chiller set point safety alarms.') and a low oil alarm generated. This enables the set point value and the safety time to be much tighter. This safety is interrogated when the compressor is on and not in a pump down state.

Low Suction Pressure

If the suction pressure drops below the value of the set point or the digital input turns ON and it remains there for the time specified in the safety time, the compressor will be locked out and a low suction alarm generated. For the first 5 minutes after the compressor has started the safety time is extend by 2 minutes, this enables the set point safety time to be set much tighter for normal operation. This safety is bypassed when the compressor is in the "CMP PUMP DOWN" state. This safety can also be used as a freeze protection based upon the suction PSI.

Unsafe Suction Pressure

This safety is similar to the low suction pressure safety except this set point can be set up with a lower value and a very short safety time. If the suction pressure drops below the value of the set point or the digital input turns ON and it remains there for the time specified in the safety time of that set point, the compressor will be locked out and a low suction alarm generated. This safety will always cause a lock out on the first trip requiring a manual reset to restart the compressor. For the first 5 minutes after the compressor has started the safety time is extend by twice the normal time delay, this enables the set point safety time to be set much tighter for normal operation. . This safety is bypassed when the compressor is in the "CMP PUMP DOWN" state.

Low Discharge Pressure

If the discharge pressure drops below the value of the set point and it remains there for the time specified in the safety time of that set point, the compressor will be locked out and a low discharge alarm generated.

High Discharge Pressure (SAFETY IS ALWAYS CHECKED)

If the discharge pressure raised above the value of the set point or the digital input turns ON and it remains there for the time specified in the safety time of that set point, the compressor will be locked out and a high discharge alarm generated.

High Discharge Temperature (SAFETY IS ALWAYS CHECKED)

If the discharge temperature analog input rises above the value of the set point or the digital input turns ON and it remains there for the time specified in the safety time, the compressor will be locked out and a high temperature alarm generated.

HI Motor Temp or Motor Fault (SAFETY IS ALWAYS CHECKED)

If the high motor temperature input rises above the value of the set point or the digital input turns ON and it remains there for the time specified in the safety time, the compressor will be locked out and a high motor temperature or motor fault alarm generated.

Hi Oil Temp

If the oil temperature rises above the value of the set point or the digital input turns ON and it remains there for the time specified in the safety time of that set point, the compressor will be locked out and a high oil temperature alarm generated.

Hi Motor Amp

If the ampere analog input rises above the value of the set point or the digital input turns ON and it remains there for the time specified in the safety time of that set point, the compressor will be locked out and a high motor amp alarm generated. This safety is bypassed for the first 3 seconds after a compressor has started.

Low Motor Amp

If the ampere analog input drops below the value of the set point and it remains there for the time specified in the safety time of that set point, the compressor will be locked out and a low motor amp alarm generated. This alarm can be used to indicate low refrigerant. This safety is bypassed for the first 3 seconds after a compressor has started.

No Compress Proof

If a compressor is called to be on and the compressor proof input is off (this is a digital input), a NO COMP PROOF alarm will be generated.

High Oil Seal Temperature (Screw Compressors only)

If the oil seal temperature analog input rises above the value of the set point and it remains there for the time specified in the safety time of that set point, the compressor will be locked out and a high oil seal alarm generated. This safety is bypassed for the first 4 minutes after a compressor has started and when the compressor is in the "CMP PUMP DOWN" state.

Dirty Oil Filter (Fixed Step Compressors only)

If the difference between the discharge pressure minus the oil pressure is above the value of the set point and it remains there for the time specified in the safety time of that set point a dirty oil filter alarm will generate. If the difference raises 20.0 above the set point then the compressor is locked out on the first trip requiring a manual reset to restart the compressor.

Revision/Disclaimer Page

Date	Author	Description of Changes
2015-11-15	BT	Conert to Version 17
2015-12/15-15	DEW	Covert Manual to Indesign
2015-12-21-15	DEW	Corrections from Bob
2016-07-06	DEW	Add Refr Multiple Evaporator/Reheat Solenolds Section
2016-11-21	DEW	Edits from Bob T
2016-11-29	DEW	Edits from Bob T on setpoints
2017-02-03	DEW	Edits from Jeff
2017-05-15	DEW	Edits for BMS-STATES
2017-10-17	DEW	Edits for rotating coil defrost setpoint 118, Refr Defrost Section
2017-23-24-17	DEW	Add to Standard Control Options - sec Force Digital Compressor Speed - setpoint #31
2019-10-22	DEW	Make changes as per Jeff
2019-12-9	DEW	Change Authorization for RS485 Service Add PID to Manual, remove reference to subcooler
2020-6-17	DEW	Modify EXV SECTION UP SCREEN SHOTS Ver 2.6
2020-8-07	DEW	Change made to Compressor Rotation section Chapter 9-13
2020-8-07	DEW	Changes made to Chapter 20-25 EXV chapter
2020-8-07	DEW	Changes made to Chapter 29 BMS Unit and Compressor States
2020-8-07	DEW	Changes made to setpoints 40, 41, 43 add PIP



Providing HVAC/R Control Solutions Worldwide

5580 Enterprise Pkwy. Fort Myers, FL 33905

Office: (239) 694-0089

Fax: (239) 694-0031

www.mcscontrols.com