



BMS COMMUNICATION MCS-BMS-GATEWAY-NL

5580 Enterprise Pkwy.
Fort Myers, FL 33905

Office: 239-694-0089
Fax: 239-694-0031

www.mcscontrols.com

For Interfacing MCS-MAGNUM to:
Building Automation Systems Protocols
MCS, Modbus RTU, Modbus IP, Ethernet,
BACnet IP, BACnet MS/TP, N2,



MCS-MAGNUM

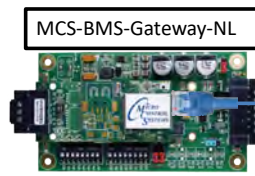

MCS-BMS-Gateway-NL

RS485 or
LonWorks



Building
Management
System

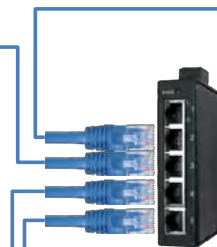

Ethernet



Internet
Router



MCS-Touch

**MCS Total
Solution
for all your
Control
Needs**



**Energy Efficient and
RoHS Compliant**

Revision/Disclaimer Page

Date	Author	Description of Changes
4-12-16	DEW	Restructured manual
4-14-16	DEW	Changes made from Ray
7-8-16	DEW	Merge MCS-BMS-GATEWAY VER 2.0
10-03-16	DEW	Update drawings, revised back startup section
12-27-16	DEW	Creating CSV Files
11-30-17	DEW	Remove address 0 in dip switch settings
8-14-17	DEW	Added Alarm BMS info
10-31-19	DEW	Update photos to new style
11-19-19	DEW	Add Modbus IP to RTU
1-29-2020	DEW	Change baud rate for Metasys N2 to 9600
04-12-2021	DEW	Changes made from startup guide
08-17-2021	DEW	CREATE MANUAL FOR MCS-BMS-GATEWAY-NL

The MCS Commitment is to provide practical solutions for the industries needs and to be both a leader and partner in the effective use of microprocessor controls.

Micro Control Systems, Inc.
5580 Enterprise Parkway
Fort Myers, Florida 33905
PH:(239) 694-0089 FAX:(239) 694-0031
www.mcscontrols.com

All information contained within this document is considered to be proprietary information of Micro Control Systems, Inc. No information or data from this document shall be published, used, reproduced, transmitted, or disclosed to others outside your organization without the prior expressed written consent of Micro Control Systems, Inc. This document and the information contained herein shall be treated as proprietary. Reasonable provisions shall be provided to ensure that this information remains proprietary by your employees, agents, and other personnel that may have access to this document.

Copyright ©2021

Table of Contents

Chapter - 1.	BMS Communication Protocols	5
1.1.	MCS-Magnum to BMS Connections	5
1.2.	Sensor Input Points	6
1.3.	Relay Output Points.....	7
1.4.	Setpoints.....	8
1.5.	Chiller/Compressor States.....	8
1.6.	Other Points.....	9
1.7.	Unit Alarms	12
1.8.	Compressor Alarms	13
1.9.	Network inputs to MCS-MAGNUM	19
1.10.	MCS Capacity Control State Chart.....	20
1.11.	MCS Compressor Control State Chart	20
1.12.	MCS-MAGNUM BMS PROTOCOLS.....	21
1.12.1	BACnet OVER IP PROTOCOL.....	21
1.12.2	ETHERNET NETWORK PROTOCOL.....	21
1.12.3	MODBUS RTU PROTOCOL.....	22
1.12.4	MODBUS TCP/IP PROTOCOL.....	22
1.13.	PROTOCOLS USING MCS-BMS-GATEWAY	22
Chapter - 2.	NETWORK PROTOCOLS	23
2.1.	Protocols MCS controllers support:.....	23
2.2.	MCS-MAGNUM USING RS-485	24
2.3.	Wiring Multiple MCS Controllers.....	25
2.4.	MCS-MAGNUM USING ETHERNET	26
2.5.	EXAMPLE NETWORK	27
2.5.1	Standalone MCS-Magnum	27
2.5.2	MULTIPLE MCS-MAGNUM ENCLOSURES.....	27
2.6.	MULTIPLE MCS-MAGNUM BMS RS485 WIRING DIAGRAM.....	29
Chapter - 3.	FIELD SERVER TOOLBOX	30
Chapter - 1.	Introduction	33
1.1.	BTL Mark – BACnet Testing Laboratory	33
1.2.	UL and RoHS Certification	33
Chapter - 2.	Quick Start Guide	34
Chapter - 3.	Setup for MCS-BMS-GATEWAY-NL	35
3.1.	Record Identification Data	35
3.2.	Configuring Device Communications	35
3.2.1	Set COM settings on all Devices Connected to the MCS-BMS-GATEWAY-NL.....	35
3.2.2	Set IP Address for each MCS-MAGNUM connected to the MCS-BMS-GATEWAY-NL.....	35
3.3.	BMS Network Settings:	36
3.3.1	BACnet MS/TP, N2 and Modbus IP to RTU.....	36
Figure 5	Protocol Selection Switch Tables.....	36
3.3.2	BACnet MS/TP: Setting the MAC Address for BMS Network	37
3.3.3	BACnet MS/TP and BACnet/IP: Setting the Device Instance	37
3.3.4	Metasys N2: Setting the Node-ID	37
3.3.5	BACnet MS/TP: Setting the Serial Baud Rate for BMS Network.....	38
3.3.5.1.	Baud Rate DIP Switch Selection	39
Chapter - 4.	Interfacing MCS-BMS-GATEWAY-NL to Devices	40
4.1.	MCS-BMS-GATEWAY-NL Connection Ports	40
4.2.	Wiring diagram for connecting the MCS-Magnum.....	41
4.3.	Device Connections to MCS-BMS-GATEWAY-NL.....	42
4.4.	MCS-MAGNUM Address Settings.....	43
4.5.	Biasing the RS-485 Device Network	45
4.6.	End of Line Termination Switch for the Modbus RS-485 Device Network.....	46
4.7.	Power-Up MCS-BMS-GATEWAY-NL.....	47

Chapter - 5. Programming a MCS-BMS GATEWAY-NL48

- 5.1. Connecting A PC to the MCS-BMS-GATEWAY-NL48
- 5.2. Connect the PC to MCS-BMS-GATEWAY-NL via the Ethernet Port.....48
 - 5.2.1 For Windows 7 or later.....48
- 6.1. How to Create CSV Files:.....49
- 6.2. How to Program the MCS-BMS-GATEWAY-NL with the CSV Files:52

Chapter - 7. APPENDIX53

- 7.1. BMS Address DIP Switch Settings53

Chapter - 1. BMS Communication Protocols

The MCS-Magnum supports as standard: BACnet IP, Modbus RTU, and Modbus TCP/IP protocols.

Using the MCS-BMS-GATEWAY, the MCS-Magnum can also support Johnson N2, and BACnet MS/TP.

Supported baud rates for Modbus RTU and Johnson N2 are 4800bps, 9600bps, 19200bps, 38400bps, and 57600bps.

1.1. MCS-Magnum to BMS Connections

MCS-BMS-GATEWAY-NL to MCS-MAGNUM-N-12

Mounting & Wiring Diagram

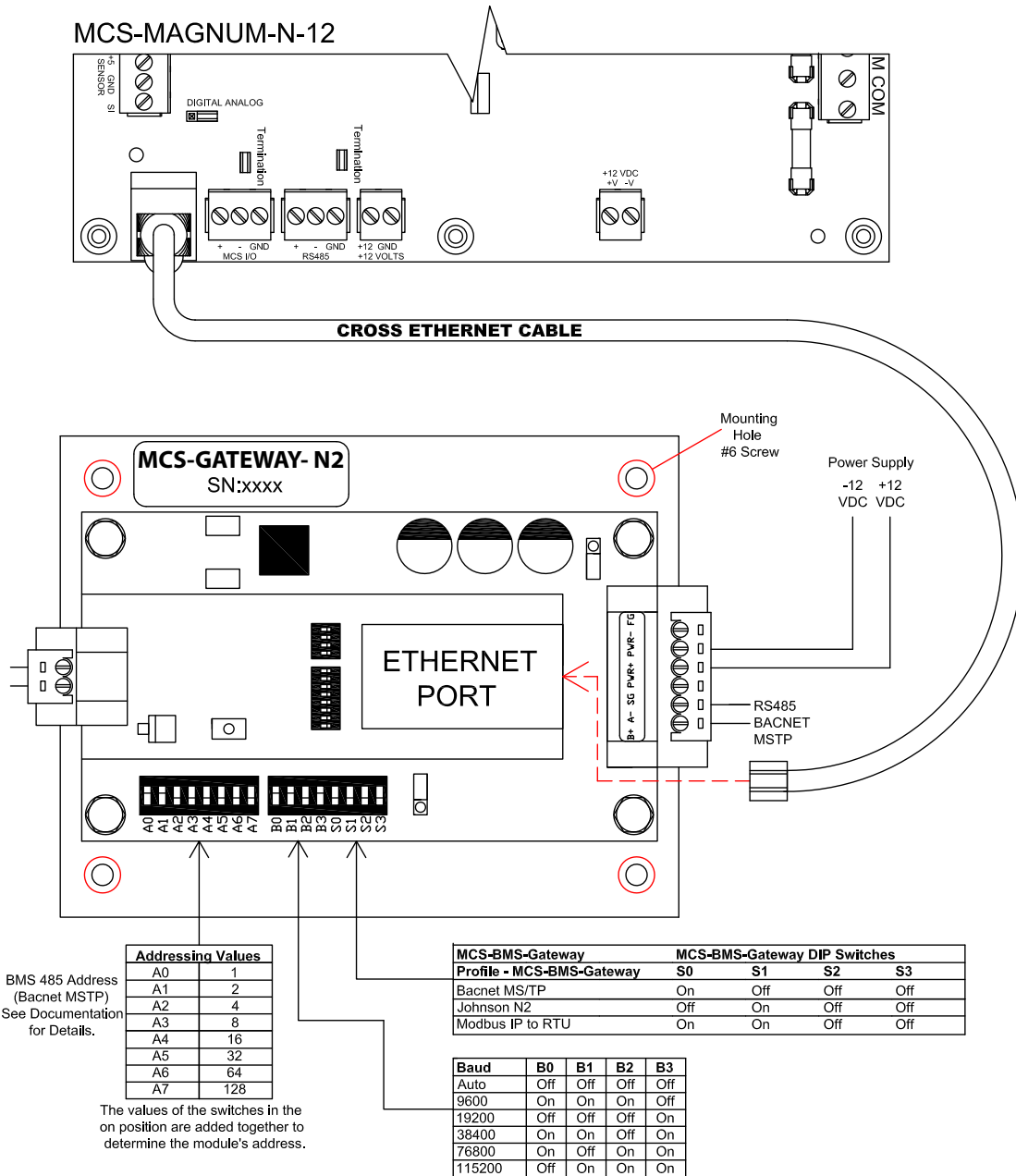

1.2. Sensor Input Points

Sensor numbering is based upon the MCS-MAGNUM or SI16-AO4 (SI-Base and SI-EXT) hardware type board Notable BACnet properties available: Units

Magnum	BACnet ID	BACnet Name	Modbus Register	N2
Sensor M-1	AI: 1	Refer to Config	*30001	*AI: 1
Sensor M-2	AI: 2	Refer to Config	*30002	*AI: 2
Sensor M-3	AI: 3	Refer to Config	*30003	*AI: 3
Sensor M-4	AI: 4	Refer to Config	*30004	*AI: 4
Sensor M-5	AI: 5	Refer to Config	*30005	*AI: 5
Sensor M-6	AI: 6	Refer to Config	*30006	*AI: 6
Sensor M-7	AI: 7	Refer to Config	*30007	*AI: 7
Sensor M-8	AI: 8	Refer to Config	*30008	*AI: 8
Sensor M-9	AI: 9	Refer to Config	*30009	*AI: 9
Sensor M-10	AI:10	Refer to Config	*30010	*AI: 10
Sensor M-11	AI:11	Refer to Config	*30011	*AI: 11
Sensor M-12	AI:12	Refer to Config	*30012	*AI: 12
Sensor M-13	AI:13	Refer to Config	*30013	*AI: 13
Sensor M-14	AI:14	Refer to Config	*30014	*AI: 14
Sensor M-15	AI:15	Refer to Config	*30015	*AI: 15
Sensor M-16	AI:16	Refer to Config	*30016	*AI: 16
Sensor 1-1	AI:17	Refer to Config	*30017	*AI: 17
Sensor 1-2	AI:18	Refer to Config	*30018	*AI: 18
Sensor 1-3	AI:19	Refer to Config	*30019	*AI: 19
Sensor 1-4	AI:20	Refer to Config	*30020	*AI: 20
Sensor 1-5	AI:21	Refer to Config	*30021	*AI: 21
Sensor 1-6	AI:22	Refer to Config	*30022	*AI: 22
Sensor 1-7	AI:23	Refer to Config	*30023	*AI: 23
Sensor 1-8	AI:24	Refer to Config	*30024	*AI: 24
Sensor 1-9	AI:25	Refer to Config	*30025	*AI: 25
Sensor 1-10	AI:26	Refer to Config	*30026	*AI: 26
Sensor 1-11	AI:27	Refer to Config	*30027	*AI: 27
Sensor 1-12	AI:28	Refer to Config	*30028	*AI: 28
Sensor 1-13	AI:29	Refer to Config	*30029	*AI: 29
Sensor 1-14	AI:30	Refer to Config	*30030	*AI: 30
Sensor 1-15	AI:31	Refer to Config	*30031	*AI: 31
Sensor 1-16	AI:32	Refer to Config	*30032	*AI: 32
Sensor 2-1	AI:33	Refer to Config	*30033	*AI: 33
Sensor 2-2	AI:34	Refer to Config	*30034	*AI: 34
Sensor 2-3	AI:35	Refer to Config	*30035	*AI: 35
Sensor 2-4	AI:36	Refer to Config	*30036	*AI: 36
Sensor 2-5	AI:37	Refer to Config	*30037	*AI: 37
Sensor 2-6	AI:38	Refer to Config	*30038	*AI: 38
Sensor 2-7	AI:39	Refer to Config	*30039	*AI: 39
Sensor 2-8	AI:40	Refer to Config	*30040	*AI: 40

Magnum	BACnet ID	BACnet Name	Modbus Register	N2
Sensor 2-9	AI:41	Refer to Config	*30041	*AI: 41
Sensor 2-10	AI:42	Refer to Config	*30042	*AI: 42
Sensor 2-11	AI:43	Refer to Config	*30043	*AI: 43
Sensor 2-12	AI:44	Refer to Config	*30044	*AI: 44
Sensor 2-13	AI:45	Refer to Config	*30045	*AI: 45
Sensor 2-14	AI:46	Refer to Config	*30046	*AI: 46
Sensor 2-15	AI:47	Refer to Config	*30047	*AI: 47
Sensor 2-16	AI:48	Refer to Config	*30048	*AI: 48
Sensor 3-1	AI:49	Refer to Config	*30049	*AI:49
Sensor 3-2	AI:50	Refer to Config	*30050	*AI: 50
Sensor 3-3	AI:51	Refer to Config	*30051	*AI: 51
Sensor 3-4	AI:52	Refer to Config	*30052	*AI: 52
Sensor 3-5	AI:53	Refer to Config	*30053	*AI: 53
Sensor 3-6	AI:54	Refer to Config	*30054	*AI: 54
Sensor 3-7	AI:55	Refer to Config	*30055	*AI: 55
Sensor 3-8	AI:56	Refer to Config	*30056	*AI: 56
Sensor 3-9	AI:57	Refer to Config	*30057	*AI: 57
Sensor 3-10	AI:58	Refer to Config	*30058	*AI: 58
Sensor 3-11	AI:59	Refer to Config	*30059	*AI: 59
Sensor 3-12	AI:60	Refer to Config	*30060	*AI: 60
Sensor 3-13	AI:61	Refer to Config	*30061	*AI: 61
Sensor 3-14	AI:62	Refer to Config	*30062	*AI: 62
Sensor 3-15	AI:63	Refer to Config	*30063	*AI: 63
Sensor 3-16	AI:64	Refer to Config	*30064	*AI: 64
Sensor 4-1	AI:65	Refer to Config	*30065	*AI: 65
Sensor 4-2	AI:66	Refer to Config	*30066	*AI: 66
Sensor 4-3	AI:67	Refer to Config	*30067	*AI: 67
Sensor 4-4	AI:68	Refer to Config	*30068	*AI: 68
Sensor 4-5	AI:69	Refer to Config	*30069	*AI: 69
Sensor 4-6	AI:70	Refer to Config	*30070	*AI: 70
Sensor 4-7	AI:71	Refer to Config	*30071	*AI: 71
Sensor 4-8	AI:72	Refer to Config	*30072	*AI: 72
Sensor 4-9	AI:73	Refer to Config	*30073	*AI: 73
Sensor 4-10	AI:74	Refer to Config	*30074	*AI: 74
Sensor 4-11	AI:75	Refer to Config	*30075	*AI: 75
Sensor 4-12	AI:76	Refer to Config	*30076	*AI: 76
Sensor 4-13	AI:77	Refer to Config	*30077	*AI: 77
Sensor 4-14	AI:78	Refer to Config	*30078	*AI: 78
Sensor 4-15	AI:79	Refer to Config	*30079	*AI: 79
Sensor 4-16	AI:80	Refer to Config	*30080	*AI: 80

*- Indicates value multiplied by 10 to include one decimal place. (I.e. BMS value of 500 indicates actual value 50.0)

1.3. Relay Output Points

Relay Output points are read-only. Output numbering is based upon MCS-RO-10 (MCS-RO BASE, MCS-RO-EXT) hardware type board

Magnum	BACnet ID	BACnet Name	Modbus	N2
Relay M-1	BO: 1	Refer to Config	00001	BO: 1
Relay M-2	BO: 2	Refer to Config	00002	BO: 2
Relay M-3	BO: 3	Refer to Config	00003	BO: 3
Relay M-4	BO: 4	Refer to Config	00004	BO: 4
Relay M-5	BO: 5	Refer to Config	00005	BO: 5
Relay M-6	BO: 6	Refer to Config	00006	BO: 6
Relay M-7	BO: 7	Refer to Config	00007	BO: 7
Relay M-8	BO: 8	Refer to Config	00008	BO: 8
Relay M-9	BO: 9	Refer to Config	00009	BO: 9
Relay M-10	BO:10	Refer to Config	00010	BO: 10
Relay 1-1	BO:11	Refer to Config	00011	BO: 11
Relay 1-2	BO:12	Refer to Config	00012	BO: 12
Relay 1-3	BO:13	Refer to Config	00013	BO: 13
Relay 1-4	BO:14	Refer to Config	00014	BO: 14
Relay 1-5	BO:15	Refer to Config	00015	BO: 15
Relay 1-6	BO:16	Refer to Config	00016	BO: 16
Relay 1-7	BO:17	Refer to Config	00017	BO: 17
Relay 1-8	BO:18	Refer to Config	00018	BO: 18
Relay 1-9	BO:19	Refer to Config	00019	BO: 19
Relay 1-10	BO:20	Refer to Config	00020	BO: 20
Relay 2-1	BO:21	Refer to Config	00021	BO: 21
Relay 2-2	BO:22	Refer to Config	00022	BO: 22
Relay 2-3	BO:23	Refer to Config	00023	BO: 23
Relay 2-4	BO:24	Refer to Config	00024	BO: 24
Relay 2-5	BO:25	Refer to Config	00025	BO: 25
Relay 2-6	BO:26	Refer to Config	00026	BO: 26
Relay 2-7	BO:27	Refer to Config	00027	BO: 27
Relay 2-8	BO:28	Refer to Config	00028	BO: 28
Relay 2-9	BO:29	Refer to Config	00029	BO: 29
Relay 2-10	BO:30	Refer to Config	00030	BO: 30
Relay 3-1	BO:31	Refer to Config	00031	BO: 31
Relay 3-2	BO:32	Refer to Config	00032	BO: 32
Relay 3-3	BO:33	Refer to Config	00033	BO: 33
Relay 3-4	BO:34	Refer to Config	00034	BO: 34
Relay 3-5	BO:35	Refer to Config	00035	BO: 35
Relay 3-6	BO:36	Refer to Config	00036	BO: 36
Relay 3-7	BO:37	Refer to Config	00037	BO: 37
Relay 3-8	BO:38	Refer to Config	00038	BO: 38
Relay 3-9	BO:39	Refer to Config	00039	BO: 39
Relay 3-10	BO:40	Refer to Config	00040	BO: 40

Magnum	BACnet ID	BACnet Name	Modbus	N2
Relay 4-1	BO:41	Refer to Config	00041	BO: 41
Relay 4-2	BO:42	Refer to Config	00042	BO: 42
Relay 4-3	BO:43	Refer to Config	00043	BO: 43
Relay 4-4	BO:44	Refer to Config	00044	BO: 44
Relay 4-5	BO:45	Refer to Config	00045	BO: 45
Relay 4-6	BO:46	Refer to Config	00046	BO: 46
Relay 4-7	BO:47	Refer to Config	00047	BO: 47
Relay 4-8	BO:48	Refer to Config	00048	BO: 48
Relay 4-9	BO:49	Refer to Config	00049	BO: 49
Relay 4-10	BO:50	Refer to Config	00050	BO: 50
Relay 5-1	BO:51	Refer to Config	00051	BO: 51
Relay 5-2	BO:52	Refer to Config	00052	BO: 52
Relay 5-3	BO:53	Refer to Config	00053	BO: 53
Relay 5-4	BO:54	Refer to Config	00054	BO: 54
Relay 5-5	BO:55	Refer to Config	00055	BO: 55
Relay 5-6	BO:56	Refer to Config	00056	BO: 56
Relay 5-7	BO:57	Refer to Config	00057	BO: 57
Relay 5-8	BO:58	Refer to Config	00058	BO: 58
Relay 5-9	BO:59	Refer to Config	00059	BO: 59
Relay 5-10	BO:60	Refer to Config	00060	BO: 60
Relay 6-1	BO:61	Refer to Config	00061	BO: 61
Relay 6-2	BO:62	Refer to Config	00062	BO: 62
Relay 6-3	BO:63	Refer to Config	00063	BO: 63
Relay 6-4	BO:64	Refer to Config	00064	BO: 64
Relay 6-5	BO:65	Refer to Config	00065	BO: 65
Relay 6-6	BO:66	Refer to Config	00066	BO: 66
Relay 6-7	BO:67	Refer to Config	00067	BO: 67
Relay 6-8	BO:68	Refer to Config	00068	BO: 68
Relay 6-9	BO:69	Refer to Config	00069	BO: 69
Relay 6-10	BO:70	Refer to Config	00760	BO: 70
Relay 7-1	BO:71	Refer to Config	00071	BO: 71
Relay 7-2	BO:72	Refer to Config	00072	BO: 72
Relay 7-3	BO:73	Refer to Config	00073	BO: 73
Relay 7-4	BO:74	Refer to Config	00074	BO: 74
Relay 7-5	BO:75	Refer to Config	00075	BO: 75
Relay 7-6	BO:76	Refer to Config	00076	BO: 76
Relay 7-7	BO:77	Refer to Config	00077	BO: 77
Relay 7-8	BO:78	Refer to Config	00078	BO: 78
Relay 7-9	BO:79	Refer to Config	00079	BO: 79
Relay 7-10	BO:80	Refer to Config	00070	BO: 80

*- Indicates value multiplied by 10 to include one decimal place. (I.e. BMS value of 500 indicates actual value 50.0)

Analog Output Points are read-only. Output numbering is based upon SI16-AO4 (SI-Base and SI-EXT) hardware type board. Notable BACnet properties available: Units

Magnum	BACnet ID	BACnet Name	Modbus Register	N2
Analog Out M-1	AO:1	Refer to Config	*30201	*AO: 1
Analog Out M-2	AO:2	Refer to Config	*30202	*AO: 2
Analog Out M-3	AO:3	Refer to Config	*30203	*AO: 3
Analog Out M-4	AO:4	Refer to Config	*30204	*AO: 4
Analog Out 1-1	AO:5	Refer to Config	*30205	*AO: 5
Analog Out 1-2	AO:6	Refer to Config	*30206	*AO: 6
Analog Out 1-3	AO:7	Refer to Config	*30207	*AO: 7
Analog Out 1-4	AO:7	Refer to Config	*30208	*AO: 8
Analog Out 2-1	AO:8	Refer to Config	*30209	*AO: 9
Analog Out 2-2	AO:10	Refer to Config	*30210	*AO: 10
Analog Out 2-3	AO:11	Refer to Config	*30211	*AO: 11
Analog Out 2-4	AO:12	Refer to Config	*30212	*AO: 12
Analog Out 3-1	AO:13	Refer to Config	*30213	*AO: 13
Analog Out 3-2	AO:14	Refer to Config	*30214	*AO: 14
Analog Out 3-3	AO:15	Refer to Config	*30215	*AO: 15
Analog Out 3-4	AO:16	Refer to Config	*30216	*AO: 16
Analog Out 4-1	AO:17	Refer to Config	*30217	*AO: 17
Analog Out 4-2	AO:18	Refer to Config	*30218	*AO: 18
Analog Out 4-3	AO:19	Refer to Config	*30219	*AO: 19
Analog Out 4-4	AO:20	Refer to Config	*30220	*AO: 20

*- Indicates value multiplied by 10 to include one decimal place. (I.e. BMS value of 500 indicates actual value 50.0)

1.4. Setpoints

Setpoints are read-only. Notable BACnet properties available: Units

Magnum	BACnet ID	BACnet Name	Modbus	N2
Setpoint #1	AV:0	STP# 1-<Setpoint name>	40301	ADF:1
Setpoint #21	AV:88	STP# 21-<Setpoint name>	40321	ADF:89
Setpoint #163	AV:230	STP# 163-<Setpoint name>	40463	ADF:231

1.5. Chiller/Compressor States

State values are read-only. Notable BACnet properties available: Number of States, State-Text (Contains character text of current state)

Magnum	BACnet ID	BACnet Name	Modbus Register	N2
Chiller Unit State	MV:0	CHILLER STATE	30306	BYT:1
Compressor #1 State	MV:1	COMPRESSOR #1 STATE	30307	BYT:2
Compressor #2 State	MV:2	COMPRESSOR #2 STATE	30308	BYT:3

Magnum	BACnet ID	BACnet Name	Modbus Register	N2
Compressor #3 State	MV:3	COMPRESSOR #3 STATE	30309	BYT:4
Compressor #4 State	MV:4	COMPRESSOR #4 STATE	30310	BYT:5
Compressor #5 State	MV:5	COMPRESSOR #5 STATE	30311	BYT:6
Compressor #6 State	MV:6	COMPRESSOR #6 STATE	30312	BYT:7
Compressor #7 State	MV:7	COMPRESSOR #7 STATE	30313	BYT:8
Compressor #8 State	MV:8	COMPRESSOR #8 STATE	30314	BYT:9
Compressor #9 State	MV:130	COMPRESSOR #9 STATE	30560	BYT:131
Compressor #10 State	MV:131	COMPRESSOR #10 STATE	30561	BYT:132
Compressor #11 State	MV:132	COMPRESSOR #11 STATE	30562	BYT:133
Compressor #12 State	MV:133	COMPRESSOR #12 STATE	30563	BYT:134
Compressor #13 State	MV:134	COMPRESSOR #13 STATE	30564	BYT:135
Compressor #14 State	MV:135	COMPRESSOR #14 STATE	30565	BYT:136
Compressor #15 State	MV:136	COMPRESSOR #15 STATE	30566	BYT:137
Compressor #16 State	MV:137	COMPRESSOR #16 STATE	30567	BYT:138
Compressor #17 State	MV:138	COMPRESSOR #17 STATE	30568	BYT:139
Compressor #18 State	MV:139	COMPRESSOR #18 STATE	30569	BYT:140
Compressor #19 State	MV:140	COMPRESSOR #19 STATE	30570	BYT:141
Compressor #20 State	MV:141	COMPRESSOR #20 STATE	30571	BYT:142

1.6. Other Points

These points are read-only.

Magnum	BACnet ID	BACnet Name	Modbus	N2
Wanted FLA%	AV:3	Wanted FLA%	30318	ADF:4
Steps Wanted	AV:4	Steps Wanted On	30315	ADF:5
Steps On	AV:5	Steps On	30316	ADF:6
Step Delay	AV:6	Step Delay	30317	ADF:7
Compressor #1 FLA%	AV:7	C1_FL A%	*30319	*ADF:8
Compressor #1 Sat Suction	AV:10	C1_ Sat Suct	*30327	*ADF:11
Compressor #1 Sat Disch	AV:11	C1_ Sat Disch	*30329	*ADF:12
Compressor #1 Disch SH	AV:12	C1_ Disch SH	*30330	*ADF:13
Compressor #1 Suct SH	AV:13	C1_ Suct SH	*30328	*ADF:14
Compressor #1 Oil Pres Diff	AV:63	C1_ Oil Pres Diff	*30375	*ADF:64
Compressor #2 FLA%	AV:14	C2_FL A%	*30320	*ADF:15
Compressor #2 Sat Suction	AV:17	C2_ Sat Suct	*30331	*ADF:18
Compressor #2 Sat Disch	AV:18	C2_ Sat Disch	*30333	*ADF:19
Compressor #2 Disch SH	AV:19	C2_ Disch SH	*30334	*ADF:20
Compressor #2 Suct SH	AV:20	C2_ Suct SH	*30332	*ADF:21
Compressor #2 Oil Pres Diff	AV:64	C2_ Oil Pres Diff	*30376	*ADF:65
Compressor #3 FLA%	AV:21	C3_FL A%	*30321	*ADF:22
Compressor #3 Sat Suction	AV:24	C3_ Sat Suct	*30335	*ADF:25
Compressor #3 Sat Disch	AV:25	C3_ Sat Disch	*30337	*ADF:26
Compressor #3 Disch SH	AV:26	C3_ Disch SH	*30338	*ADF:27
Compressor #3 Suct SH	AV:27	C3_ Suct SH	*30336	*ADF:28
Compressor #3 Oil Pres Diff	AV:65	C3_ Oil Pres Diff	*30377	*ADF:66
Compressor #4 FLA%	AV:28	C4_FL A%	*30322	*ADF:29
Compressor #4 Sat Suction	AV:31	C4_ Sat Suct	*30339	*ADF:32
Compressor #4 Sat Disch	AV:32	C4_ Sat Disch	*30341	*ADF:33

Magnum	BACnet ID	BACnet Name	Modbus	N2
Compressor #4 Disch SH	AV:33	C4_Disch SH	*30342	*ADF:34
Compressor #4 Suct SH	AV:34	C4_Suct SH	*30340	*ADF:35
Compressor #4 Oil Pres Diff	AV:66	C4_Oil Pres Diff	*30378	*ADF:67
Compressor #5 FLA%	AV:35	C5_FLA%	*30323	*ADF:36
Compressor #5 Sat Suction	AV:38	C5_Sat Suct	*30343	*ADF:39
Compressor #5 Sat Disch	AV:39	C5_Sat Disch	*30345	*ADF:40
Compressor #5 Disch SH	AV:40	C5_Disch SH	*30346	*ADF:41
Compressor #5 Suct SH	AV:41	C5_Suct SH	*30344	*ADF:42
Compressor #5 Oil Pres Diff	AV:67	C5_Oil Pres Diff	*30379	*ADF:68
Compressor #6 FLA%	AV:42	C6_FLA%	*30324	*ADF:43
Compressor #6 Sat Suction	AV:45	C6_Sat Suct	*30347	*ADF:46
Compressor #6 Sat Disch	AV:46	C6_Sat Disch	*30349	*ADF:47
Compressor #6 Disch SH	AV:47	C6_Disch SH	*30350	*ADF:48
Compressor #6 Suct SH	AV:48	C6_Suct SH	*30348	*ADF:49
Compressor #6 Oil Pres Diff	AV:68	C6_Oil Pres Diff	*30380	*ADF:69
Compressor #7 FLA%	AV:49	C7_FLA%	*30325	*ADF:50
Compressor #7 Sat Suction	AV:52	C7_Sat Suct	*30351	*ADF:53
Compressor #7 Sat Disch	AV:53	C7_Sat Disch	*30353	*ADF:54
Compressor #7 Disch SH	AV:54	C7_Disch SH	*30354	*ADF:55
Compressor #7 Suct SH	AV:55	C7_Suct SH	*30352	*ADF:56
Compressor #7 Oil Pres Diff	AV:69	C7_Oil Pres Diff	*30381	*ADF:70
Compressor #8 FLA%	AV:56	C8_FLA%	*30326	*ADF:57
Compressor #8 Sat Suction	AV:59	C8_Sat Suct	*30352	*ADF:53
Compressor #8 Sat Suction	AV:59	C8_Sat Suct	*30355	*ADF:60
Compressor #8 Sat Disch	AV:60	C8_Sat Disch	*30357	*ADF:61
Compressor #8 Disch SH	AV:61	C8_Disch SH	*30358	*ADF:62
Compressor #8 Suct SH	AV:62	C8_Suct SH	*30356	*ADF:63
Compressor #8 Oil Pres Diff	AV:70	C8_Oil Pres Diff	*30382	*ADF:71
Compressor #9 FLA%	AV:440	C9_FLA%	*30572	*ADF:441
Compressor #9 Sat Suction	AV: 443	C9_Sat Suct	*30584	*ADF: 442
Compressor #9 Sat Disch	AV: 444	C9_Sat Disch	*30586	*ADF: 443
Compressor #9 Disch SH	AV: 445	C9_Disch SH	*30587	*ADF: 444
Compressor #9 Suct SH	AV: 446	C9_Suct SH	*30585	*ADF: 445
Compressor #9 Oil Pres Diff	AV:524	C9_Oil Pres Diff	*30656	*ADF:525
Compressor #10 FLA%	AV:447	C10_FLA%	*30573	*ADF:448
Compressor #10 Sat Suction	AV: 450	C10_Sat Suct	*30588	*ADF: 451
Compressor #10 Sat Disch	AV: 451	C10_Sat Disch	*30590	*ADF: 452
Compressor #10 Disch SH	AV: 452	C10_Disch SH	*30591	*ADF: 453
Compressor #10 Suct SH	AV: 453	C10_Suct SH	*30589	*ADF: 454
Compressor #10 Oil Pres Diff	AV:525	C10_Oil Pres Diff	*30657	*ADF:526
Compressor #11 FLA%	AV:454	C11_FLA%	*30574	*ADF:455
Compressor #11 Sat Suction	AV: 457	C11_Sat Suct	*30592	*ADF: 458
Compressor #11 Sat Disch	AV: 458	C11_Sat Disch	*30594	*ADF: 459
Compressor #11 Disch SH	AV: 459	C11_Disch SH	*30595	*ADF: 460
Compressor #11 Suct SH	AV: 460	C11_Suct SH	*30593	*ADF: 461
Compressor #11 Oil Pres Diff	AV: 526	C11_Oil Pres Diff	*30658	*ADF: 527
Compressor #12 FLA%	AV: 461	C12_FLA%	*30575	*ADF: 462
Compressor #12 Sat Suction	AV: 464	C12_Sat Suct	*30596	*ADF: 465
Compressor #12 Sat Disch	AV: 465	C12_Sat Disch	*30598	*ADF: 466
Compressor #12 Disch SH	AV: 466	C12_Disch SH	*30599	*ADF: 467
Compressor #12 Suct SH	AV: 467	C12_Suct SH	*30597	*ADF: 468
Compressor #12 Oil Pres Diff	AV:527	C12_Oil Pres Diff	*30659	*ADF:528

Magnum	BACnet ID	BACnet Name	Modbus	N2
Compressor #13 FLA%	AV:468	C13_FLA%	*30576	*ADF:469
Compressor #13 Sat Suction	AV: 471	C13_Sat Suct	*30600	*ADF: 470
Compressor #13 Sat Disch	AV: 472	C13_Sat Disch	*30602	*ADF: 473
Compressor #13 Disch SH	AV: 473	C13_Disch SH	*30603	*ADF: 474
Compressor #13 Suct SH	AV: 474	C13_Suct SH	*30600	*ADF: 475
Compressor #13 Oil Pres Diff	AV: 528	C13_Oil Pres Diff	*30661	*ADF: 529
Compressor #14 FLA%	AV: 475	C14_FLA%	*30577	*ADF: 476
Compressor #14 Sat Suction	AV: 478	C14_Sat Suct	*30604	*ADF: 479
Compressor #14 Sat Disch	AV: 479	C14_Sat Disch	*30606	*ADF: 480
Compressor #14 Disch SH	AV: 480	C14_Disch SH	*30607	*ADF: 481
Compressor #14 Suct SH	AV: 481	C14_Suct SH	*30605	*ADF: 482
Compressor #14 Oil Pres Diff	AV: 529	C14_Oil Pres Diff	*30661	*ADF: 530
Compressor #15 FLA%	AV: 482	C15_FLA%	*30578	*ADF: 483
Compressor #15 Sat Suction	AV: 485	C15_Sat Suct	*30608	*ADF: 486
Compressor #15 Sat Disch	AV: 486	C15_Sat Disch	*30610	*ADF: 487
Compressor #15 Disch SH	AV: 487	C15_Disch SH	*30611	*ADF: 488
Compressor #15 Suct SH	AV: 488	C15_Suct SH	*30609	*ADF: 489
Compressor #15 Oil Pres Diff	AV: 530	C15_Oil Pres Diff	*3062	*ADF: 531
Compressor #16 FLA%	AV: 489	C16_FLA%	*30579	*ADF: 490
Compressor #16 Sat Suction	AV: 492	C16_Sat Suct	*30612	*ADF: 493
Compressor #16 Sat Disch	AV: 493	C16_Sat Disch	*30614	*ADF: 494
Compressor #16 Disch SH	AV: 494	C16_Disch SH	*30615	*ADF: 495
Compressor #16 Suct SH	AV: 495	C16_Suct SH	*30613	*ADF: 496
Compressor #16 Oil Pres Diff	AV: 531	C16_Oil Pres Diff	*30663	*ADF: 532
Compressor #17 FLA%	AV: 496	C17_FLA%	*30580	*ADF: 497
Compressor #17 Sat Suction	AV: 499	C17_Sat Suct	*30616	*ADF: 500
Compressor #17 Sat Disch	AV: 500	C17_Sat Disch	*30618	*ADF: 501
Compressor #17 Disch SH	AV: 501	C17_Disch SH	*30619	*ADF: 502
Compressor #17 Suct SH	AV: 502	C17_Suct SH	*30617	*ADF: 503
Compressor #17 Oil Pres Diff	AV: 532	C17_Oil Pres Diff	*30664	*ADF: 533
Compressor #18 FLA%	AV: 503	C18_FLA%	*30581	*ADF: 504
Compressor #18 Sat Suction	AV: 506	C18_Sat Suct	*30620	*ADF: 507
Compressor #18 Sat Disch	AV: 507	C18_Sat Disch	*30622	*ADF: 508
Compressor #18 Disch SH	AV: 508	C18_Disch SH	*30623	*ADF: 509
Compressor #18 Suct SH	AV: 509	C18_Suct SH	*30621	*ADF: 510
Compressor #18 Oil Pres Diff	AV: 533	C18_Oil Pres Diff	*30665	*ADF: 534
Compressor #19 FLA%	AV: 510	C19_FLA%	*30582	*ADF: 511
Compressor #19 Sat Suction	AV: 513	C19_Sat Suct	*30624	*ADF: 514
Compressor #19 Sat Disch	AV: 514	C19_Sat Disch	*30626	*ADF: 515
Compressor #19 Disch SH	AV: 515	C19_Disch SH	*30627	*ADF: 516
Compressor #19 Suct SH	AV: 516	C19_Suct SH	*30625	*ADF: 517
Compressor #19 Oil Pres Diff	AV: 534	C19_Oil Pres Diff	*30666	*ADF: 535
Compressor #20 FLA%	AV: 517	C20_FLA%	*30583	*ADF: 518
Compressor #20 Sat Suction	AV: 520	C20_Sat Suct	*30628	*ADF: 521
Compressor #20 Sat Disch	AV: 521	C20_Sat Disch	*30630	*ADF: 522
Compressor #20 Disch SH	AV: 522	C20_Disch SH	*30631	*ADF: 523
Compressor #20 Suct SH	AV: 523	C20_Suct SH	*30629	*ADF: 524
Compressor #20 Oil Pres Diff	AV: 535	C20_Oil Pres Diff	*30667	*ADF: 536

*- Indicates value multiplied by 10 to include one decimal place. (I.e. BMS value of 500 indicates actual value 50.0)

1.7. Unit Alarms

Unit Alarms	Modbus Info		BACnet Object Identifier		V17 Firmware		
	Function Type	Register	BACnet Object Type	Address	Relay output	Modbus	BACnet
EMERGENCY_STOP	04:input Register	31011	AV: Analog Value	1296	HVAC//RTU	HVAC//RTU	HVAC//RTU
FREEZE_PROTECTION	04:input Register	31012	AV: Analog Value	1297	HVAC//RTU	HVAC//RTU	HVAC//RTU
HIGH_SUMP_TEMP	04:input Register	31013	AV: Analog Value	1298	HVAC//RTU	HVAC//RTU	HVAC//RTU
PHASE_LOSS	04:input Register	31014	AV: Analog Value	1299	HVAC//RTU	HVAC//RTU	HVAC//RTU
HIGH_DELTA_TEMP	04:input Register	31015	AV: Analog Value	1300	HVAC/	HVAC/	HVAC/
VOLTAGE	04:input Register	31016	AV: Analog Value	1301	HVAC//RTU	HVAC//RTU	HVAC//RTU
SMOKE_ALARM	04:input Register	31017	AV: Analog Value	1302	No Support	No Support	No Support
FIRE_ALARM	04:input Register	31018	AV: Analog Value	1303	HVAC//RTU	HVAC//RTU	HVAC//RTU
COMMON_CONDENSER	04:input Register	31019	AV: Analog Value	1304	HVAC//RTU	HVAC//RTU	HVAC//RTU
CIRCUIT_CONDENSER	04:input Register	31020	AV: Analog Value	1305	HVAC//RTU	HVAC//RTU	HVAC//RTU
Fuild Cooler Fan Fault	04:input Register	31021	AV: Analog Value	1306	HVAC//RTU	HVAC//RTU	HVAC//RTU
PUMP_FAILURE	04:input Register	31022	AV: Analog Value	1307	HVAC//RTU	HVAC//RTU	HVAC//RTU
PROCESS_PUMP_FAILURE	04:input Register	31023	AV: Analog Value	1308	HVAC//RTU	HVAC//RTU	HVAC//RTU
PROCESS_PUMP_LOW_FLOW	04:input Register	31024	AV: Analog Value	1309	HVAC	HVAC	HVAC
BOILER_PUMP_FAULT	04:input Register	31025	AV: Analog Value	1310	HVAC	HVAC	HVAC
BOILER_PUMP_HIGH_AMPS	04:input Register	31026	AV: Analog Value	1311	HVAC	HVAC	HVAC
BOILER_PUMP_LOW_AMPS	04:input Register	31027	AV: Analog Value	1312	HVAC	HVAC	HVAC
BOILER_STAGE_FAULT	04:input Register	31028	AV: Analog Value	1313	HVAC	HVAC	HVAC
HIGH_WATER_TEMP	04:input Register	31029	AV: Analog Value	1314	HVAC//RTU	HVAC//RTU	HVAC//RTU
OVERHEAT_PROTECTION	04:input Register	31030	AV: Analog Value	1315	HVAC	HVAC	HVAC
RTU_SUPPLY_DUCT	04:input Register	31031	AV: Analog Value	1316	RTU	RTU	RTU
RTU_EXHAUST_FAN_FAULT	04:input Register	31032	AV: Analog Value	1317	RTU	RTU	RTU
RTU_MOD_GAS_HEATER_FAULT	04:input Register	31033	AV: Analog Value	1318	RTU	RTU	RTU
RTU_SCR_HEATER_FAULT	04:input Register	31034	AV: Analog Value	1319	RTU	RTU	RTU
RTU_CLOGGED_FILTER	04:input Register	31035	AV: Analog Value	1320	RTU	RTU	RTU
RTU_HIGH_STATIC_PRESSURE	04:input Register	31036	AV: Analog Value	1321	RTU	RTU	RTU
RTU_LOW_STATIC_PRESSURE	04:input Register	31037	AV: Analog Value	1322	RTU	RTU	RTU
BOILER_PUMP_FLOW_FAULT	04:input Register	31038	AV: Analog Value	1323	HVAC	HVAC	HVAC
Leaving Water Temp. Sensor Fault	04:input Register	31039	AV: Analog Value	1324	HVAC//RTU	HVAC//RTU	HVAC//RTU
Reutrn Water Temp. Sensor Fault	04:input Register	31040	AV: Analog Value	1325	HVAC//RTU	HVAC//RTU	HVAC//RTU
Evap Water Pressure In #1 Sensor Fault	04:input Register	31041	AV: Analog Value	1326	HVAC//RTU	HVAC//RTU	HVAC//RTU
Evap Water Pressure Out #1 Sensor Fault	04:input Register	31042	AV: Analog Value	1327	HVAC//RTU	HVAC//RTU	HVAC//RTU
Evap Water Pressure In #2 Sensor Fault	04:input Register	31043	AV: Analog Value	1328	HVAC//RTU	HVAC//RTU	HVAC//RTU
Evap Water Pressure Out #2 Sensor Fault	04:input Register	31044	AV: Analog Value	1329	HVAC//RTU	HVAC//RTU	HVAC//RTU
RTU Zone Temp. Sensor Fault	04:input Register	31045	AV: Analog Value	1330	HVAC//RTU	HVAC//RTU	HVAC//RTU
RTU Ambient Temp. Sensor Fault	04:input Register	31046	AV: Analog Value	1331	HVAC//RTU	HVAC//RTU	HVAC//RTU

1.8. Compressor Alarms

Compressor Alarms	V17 Firmware Supporting Alarm Indicators		
	Relay output	Modbus	BACnet
LOW_SUCTION	HVAC/RTU	HVAC/RTU	HVAC/RTU
UNSAFE_SUCTION	HVAC/RTU	HVAC/RTU	HVAC/RTU
HIGH_DISCHARGE_PSI	HVAC/RTU	HVAC/RTU	HVAC/RTU
HIGH_DISCHARGE_TEMP	HVAC/RTU	HVAC/RTU	HVAC/RTU
LOW_OIL_PSI	HVAC/RTU	HVAC/RTU	HVAC/RTU
UNSAFE_OIL_PSI	HVAC/RTU	HVAC/RTU	HVAC/RTU
HIGH_OIL_TEMP	HVAC/RTU	HVAC/RTU	HVAC/RTU
DIRTY_OIL_FILTER	HVAC/RTU	HVAC/RTU	HVAC/RTU
HIGH_OIL_SEAL_TEMP	HVAC/RTU	HVAC/RTU	HVAC/RTU
NO_CRANK_CASE_HEATER_PROOF	Not Supported	Not Supported	Not Supported
HIGH_AMPS	HVAC/RTU	HVAC/RTU	HVAC/RTU
LOW_AMPS	HVAC/RTU	HVAC/RTU	HVAC/RTU
HIGH_MOTOR_TEMP	HVAC/RTU	HVAC/RTU	HVAC/RTU
NO_COMPRESSOR_PROOF	HVAC/RTU	HVAC/RTU	HVAC/RTU
LOW_OIL_SUPERHEAT (Not Supported -no code)	Not Supported	Not Supported	Not Supported
PUMP_DOWN	HVAC/RTU	HVAC/RTU	HVAC/RTU
LOW_DISCHARGE_PSI	HVAC/RTU	HVAC/RTU	HVAC/RTU
LUBE_OIL_TEMP	HVAC/RTU	HVAC/RTU	HVAC/RTU
LUBE_OIL_PSI	HVAC/RTU	HVAC/RTU	HVAC/RTU
LUBE_OIL_TIME	HVAC/RTU	HVAC/RTU	HVAC/RTU
REFRIGERATION_LEAK	HVAC/RTU	HVAC/RTU	HVAC/RTU
LOW_REFRIGERATION_TEMP	HVAC/RTU	HVAC/RTU	HVAC/RTU
TOO_MANY_PURGES	HVAC/RTU	HVAC/RTU	HVAC/RTU
EXCESS_PURGING_TIME	HVAC/RTU	HVAC/RTU	HVAC/RTU
PURGE_FLOAT_ERROR	Not Supported	Not Supported	Not Supported
LOW_DIFFERENTIAL_PSI_RATIO	HVAC/RTU	HVAC/RTU	HVAC/RTU
LOW_SUPERHEAT	HVAC/RTU	HVAC/RTU	HVAC/RTU
LOW_DISCHARGE_SUPERHEAT	HVAC/RTU	HVAC/RTU	HVAC/RTU
LOST_LEG_PART_WINDING	HVAC/RTU	HVAC/RTU	HVAC/RTU
HIGH_PARTS_PER_MILLION_LEAK	Not Supported	Not Supported	Not Supported
HIGH_REFRIGERATION_LEVEL	HVAC/RTU	HVAC/RTU	HVAC/RTU
LOW_OIL_LEVEL	HVAC/RTU	HVAC/RTU	HVAC/RTU
NO_FLOW	Not Supported	Not Supported	Not Supported
OIL_FLOW	HVAC/RTU	HVAC/RTU	HVAC/RTU
COMPRESSOR_SPEED_FAULT	HVAC/RTU	HVAC/RTU	HVAC/RTU
LOW_TANDEM_SUPERHEAT	Not Supported	Not Supported	Not Supported
HIGH_TANDEM_SUPERHEAT	Not Supported	Not Supported	Not Supported
EXCESS_SURGES	HVAC/RTU	HVAC/RTU	HVAC/RTU

Compressor Alarms	V17 Firmware Supporting Alarm Indicators		
	Relay output	Modbus	BACnet
HIGH_SUPERHEAT	HVAC/RTU	HVAC/RTU	HVAC/RTU
Suction Temperature Sensor Fault	HVAC/RTU	HVAC/RTU	HVAC/RTU
Discharge Temperature Sensor Fault	HVAC/RTU	HVAC/RTU	HVAC/RTU
Suction Pressure Sensor Fault	HVAC/RTU	HVAC/RTU	HVAC/RTU
Discharge Pressure Sensor Fault	HVAC/RTU	HVAC/RTU	HVAC/RTU
Oil Pressure Sensor Fault	HVAC/RTU	HVAC/RTU	HVAC/RTU
Oil Temperature Sensor Fault	HVAC/RTU	HVAC/RTU	HVAC/RTU
Motor Temperature Sensor Fault	HVAC/RTU	HVAC/RTU	HVAC/RTU
Evap Refrigerant Temperature Sensor Fault	HVAC/RTU	HVAC/RTU	HVAC/RTU
Evap Refrigerant Level Sensor Fault	HVAC/RTU	HVAC/RTU	HVAC/RTU
Oil Seal Temperature Sensor Fault	HVAC/RTU	HVAC/RTU	HVAC/RTU
Pre-Oil Filter Pressure Sensor Fault	HVAC/RTU	HVAC/RTU	HVAC/RTU
Circuit Leaving Water Sensor Fault	HVAC/RTU	HVAC/RTU	HVAC/RTU

Modbus Register

Alarms	Modbus Function Type	Comp. #1	Comp. #2	Comp. #3	Comp. #4	Comp. #5	Comp. #6	Comp. #7	Comp. #8	Comp. #9	Comp. #10	Comp. #11	Comp. #12	Comp. #13	Comp. #14	Comp. #15	Comp. #16	Comp. #17	Comp. #18	Comp. #19	Comp. #20
LOW_SUCTION	04:input Register	31201	31252	31303	31354	31405	31456	31507	31558	31609	31660	31711	31762	31813	31864	31915	31966	32017	32068	32119	32170
UNSAFE_SUCTION	04:input Register	31202	31253	31304	31355	31406	31457	31508	31559	31610	31661	31712	31763	31814	31865	31916	31967	32018	32069	32120	32171
HIGH_DISCHARGE_PSI	04:input Register	31203	31254	31305	31356	31407	31458	31509	31560	31611	31662	31713	31764	31815	31866	31917	31968	32019	32070	32121	32172
HIGH_DISCHARGE_TEMP	04:input Register	31204	31255	31306	31357	31408	31459	31510	31561	31612	31663	31714	31765	31816	31867	31918	31969	32020	32071	32122	32173
LOW_OIL_PSI	04:input Register	31205	31256	31307	31358	31409	31460	31511	31562	31613	31664	31715	31766	31817	31868	31919	31970	32021	32072	32123	32174
UNSAFE_OIL_PSI	04:input Register	31206	31257	31308	31359	31410	31461	31512	31563	31614	31665	31716	31767	31818	31869	31920	31971	32022	32073	32124	32175
HIGH_OIL_TEMP	04:input Register	31207	31258	31309	31360	31411	31462	31513	31564	31615	31666	31717	31768	31819	31870	31921	31972	32023	32074	32125	32176
DIRTY_OIL_FILTER	04:input Register	31208	31259	31310	31361	31412	31463	31514	31565	31616	31667	31718	31769	31820	31871	31922	31973	32024	32075	32126	32177
HIGH_OIL_SEAL_TEMP	04:input Register	31209	31260	31311	31362	31413	31464	31515	31566	31617	31668	31719	31770	31821	31872	31923	31974	32025	32076	32127	32178
NO_CRANK_CASE_HEATER_PROOF	04:input Register	31210	31261	31312	31363	31414	31465	31516	31567	31618	31669	31720	31771	31822	31873	31924	31975	32026	32077	32128	32179
HIGH_AMPS	04:input Register	31211	31262	31313	31364	31415	31466	31517	31568	31619	31670	31721	31772	31823	31874	31925	31976	32027	32078	32129	32180
LOW_AMPS	04:input Register	31212	31263	31314	31365	31416	31467	31518	31569	31620	31671	31722	31773	31824	31875	31926	31977	32028	32079	32130	32181
HIGH_MOTOR_TEMP	04:input Register	31213	31264	31315	31366	31417	31468	31519	31570	31621	31672	31723	31774	31825	31876	31927	31978	32029	32080	32131	32182
NO_COMPRESSOR_PROOF	04:input Register	31214	31265	31316	31367	31418	31469	31520	31571	31622	31673	31724	31775	31826	31877	31928	31979	32030	32081	32132	32183
LOW_OIL_SUPERHEAT	04:input Register	31215	31266	31317	31368	31419	31470	31521	31572	31623	31674	31725	31776	31827	31878	31929	31980	32031	32082	32133	32184
PUMP_DOWN	04:input Register	31216	31267	31318	31369	31420	31471	31522	31573	31624	31675	31726	31777	31828	31879	31930	31981	32032	32083	32134	32185
LOW_DISCHARGE_PSI	04:input Register	31217	31268	31319	31370	31421	31472	31523	31574	31625	31676	31727	31778	31829	31880	31931	31982	32033	32084	32135	32186
LUBE_OIL_TEMP	04:input Register	31218	31269	31320	31371	31422	31473	31524	31575	31626	31677	31728	31779	31830	31881	31932	31983	32034	32085	32136	32187
LUBE_OIL_PSI	04:input Register	31219	31270	31321	31372	31423	31474	31525	31576	31627	31678	31729	31780	31831	31882	31933	31984	32035	32086	32137	32188
LUBE_OIL_TIME	04:input Register	31220	31271	31322	31373	31424	31475	31526	31577	31628	31679	31730	31781	31832	31883	31934	31985	32036	32087	32138	32189
REFRIGERATION_LEAK	04:input Register	31221	31272	31323	31374	31425	31476	31527	31578	31629	31680	31731	31782	31833	31884	31935	31986	32037	32088	32139	32190
LOW_REFRIGERATION_TEMP	04:input Register	31222	31273	31324	31375	31426	31477	31528	31579	31630	31681	31732	31783	31834	31885	31936	31987	32038	32089	32140	32191
TOO_MANY_PURGES	04:input Register	31223	31274	31325	31376	31427	31478	31529	31580	31631	31682	31733	31784	31835	31886	31937	31988	32039	32090	32141	32192
EXCESS_PURGING_TIME	04:input Register	31224	31275	31326	31377	31428	31479	31530	31581	31632	31683	31734	31785	31836	31887	31938	31989	32040	32091	32142	32193
PURGE_FLOAT_ERROR	04:input Register	31225	31276	31327	31378	31429	31480	31531	31582	31633	31684	31735	31786	31837	31888	31939	31990	32041	32092	32143	32194
LOW_DIFFERENTIAL_PSI_RATIO	04:input Register	31226	31277	31328	31379	31430	31481	31532	31583	31634	31685	31736	31787	31838	31889	31940	31991	32042	32093	32144	32195
LOW_SUPERHEAT	04:input Register	31227	31278	31329	31380	31431	31482	31533	31584	31635	31686	31737	31788	31839	31890	31941	31992	32043	32094	32145	32196
LOW_DISCHARGE_SUPERHEAT	04:input Register	31228	31279	31330	31381	31432	31483	31534	31585	31636	31687	31738	31789	31840	31891	31942	31993	32044	32095	32146	32197
LOST_LEG_PART_WINDING	04:input Register	31229	31280	31331	31382	31433	31484	31535	31586	31637	31688	31739	31790	31841	31892	31943	31994	32045	32096	32147	32198
HIGH_PARTS_PER_MILLION_LEAK	04:input Register	31230	31281	31332	31383	31434	31485	31536	31587	31638	31689	31740	31791	31842	31893	31944	31995	32046	32097	32148	32199
HIGH_REFRIGERATION_LEVEL	04:input Register	31231	31282	31333	31384	31435	31486	31537	31588	31639	31690	31741	31792	31843	31894	31945	31996	32047	32098	32149	32200
LOW_OIL_LEVEL	04:input Register	31232	31283	31334	31385	31436	31487	31538	31589	31640	31691	31742	31793	31844	31895	31946	31997	32048	32099	32150	32201
NO_FLOW	04:input Register	31233	31284	31335	31386	31437	31488	31539	31590	31641	31692	31743	31794	31845	31896	31947	31998	32049	32100	32151	32202
OIL_FLOW	04:input Register	31234	31285	31336	31387	31438	31489	31540	31591	31642	31693	31744	31795	31846	31897	31948	31999	32050	32101	32152	32203

Modbus Register

Alarms	Modbus Function Type	Comp. #1	Comp. #2	Comp. #3	Comp. #4	Comp. #5	Comp. #6	Comp. #7	Comp. #8	Comp. #9	Comp. #10	Comp. #11	Comp. #12	Comp. #13	Comp. #14	Comp. #15	Comp. #16	Comp. #17	Comp. #18	Comp. #19	Comp. #20
COMPRESSOR_SPEED_FAULT	04:input Register	31235	31286	31337	31388	31439	31490	31541	31592	31643	31694	31745	31796	31847	31898	31949	32000	32051	32102	32153	32204
LOW_TANDEM_SUPERHEAT	04:input Register	31236	31287	31338	31389	31440	31491	31542	31593	31644	31695	31746	31797	31848	31899	31950	32001	32052	32103	32154	32205
HIGH_TANDEM_SUPERHEAT	04:input Register	31237	31288	31339	31390	31441	31492	31543	31594	31645	31696	31747	31798	31849	31900	31951	32002	32053	32104	32155	32206
EXCESS_SURGES	04:input Register	31238	31289	31340	31391	31442	31493	31544	31595	31646	31697	31748	31799	31850	31901	31952	32003	32054	32105	32156	32207
HIGH_SUPERHEAT	04:input Register	31239	31290	31341	31392	31443	31494	31545	31596	31647	31698	31749	31800	31851	31902	31953	32004	32055	32106	32157	32208
Suction Temperature Sensor Fault	04:input Register	31240	31291	31342	31393	31444	31495	31546	31597	31648	31699	31750	31801	31852	31903	31954	32005	32056	32107	32158	32209
Discharge Temperature Sensor Fault	04:input Register	31241	31292	31343	31394	31445	31496	31547	31598	31649	31700	31751	31802	31853	31904	31955	32006	32057	32108	32159	32210
Suction Pressure Sensor Fault	04:input Register	31242	31293	31344	31395	31446	31497	31548	31599	31650	31701	31752	31803	31854	31905	31956	32007	32058	32109	32160	32211
Discharge Pressure Sensor Fault	04:input Register	31243	31294	31345	31396	31447	31498	31549	31600	31651	31702	31753	31804	31855	31906	31957	32008	32059	32110	32161	32212
Oil Pressure Sensor Fault	04:input Register	31244	31295	31346	31397	31448	31499	31550	31601	31652	31703	31754	31805	31856	31907	31958	32009	32060	32111	32162	32213
Oil Temperature Sensor Fault	04:input Register	31245	31296	31347	31398	31449	31500	31551	31602	31653	31704	31755	31806	31857	31908	31959	32010	32061	32112	32163	32214
Motor Temperature Sensor Fault	04:input Register	31246	31297	31348	31399	31450	31501	31552	31603	31654	31705	31756	31807	31858	31909	31960	32011	32062	32113	32164	32215
Evap Refrigerant Temp. Sensor Fault	04:input Register	31247	31298	31349	31400	31451	31502	31553	31604	31655	31706	31757	31808	31859	31910	31961	32012	32063	32114	32165	32216
Evap Refrigerant Level Sensor Fault	04:input Register	31248	31299	31350	31401	31452	31503	31554	31605	31656	31707	31758	31809	31860	31911	31962	32013	32064	32115	32166	32217
Oil Seal Temperature Sensor Fault	04:input Register	31249	31300	31351	31402	31453	31504	31555	31606	31657	31708	31759	31810	31861	31912	31963	32014	32065	32116	32167	32218
Pre-Oil Filter Presssure Sensor Fault	04:input Register	31250	31301	31352	31403	31454	31505	31556	31607	31658	31709	31760	31811	31862	31913	31964	32015	32066	32117	32168	32219
Circuit Leaving Water Sensor Fault	04:input Register	31251	31302	31353	31404	31455	31506	31557	31608	31659	31710	31761	31812	31863	31914	31965	32016	32067	32118	32169	32220

BACnet Object Identifier

Alarms	BACnet Object Type	Comp. #1	Comp. #2	Comp. #3	Comp. #4	Comp. #5	Comp. #6	Comp. #7	Comp. #8	Comp. #9	Comp. #10	Comp. #11	Comp. #12	Comp. #13	Comp. #14	Comp. #15	Comp. #16	Comp. #17	Comp. #18	Comp. #19	Comp. #20
LOW_SUCTION	Analog Value	1396	1447	1498	1549	1600	1651	1702	1753	1804	1855	1906	1957	2008	2059	2110	2161	2212	2263	2314	2365
UNSAFE_SUCTION	Analog Value	1397	1448	1499	1550	1601	1652	1703	1754	1805	1856	1907	1958	2009	2060	2111	2162	2213	2264	2315	2366
HIGH_DISCHARGE_PSI	Analog Value	1398	1449	1500	1551	1602	1653	1704	1755	1806	1857	1908	1959	2010	2061	2112	2163	2214	2265	2316	2367
HIGH_DISCHARGE_TEMP	Analog Value	1399	1450	1501	1552	1603	1654	1705	1756	1807	1858	1909	1960	2011	2062	2113	2164	2215	2266	2317	2368
LOW_OIL_PSI	Analog Value	1400	1451	1502	1553	1604	1655	1706	1757	1808	1859	1910	1961	2012	2063	2114	2165	2216	2267	2318	2369
UNSAFE_OIL_PSI	Analog Value	1401	1452	1503	1554	1605	1656	1707	1758	1809	1860	1911	1962	2013	2064	2115	2166	2217	2268	2319	2370
HIGH_OIL_TEMP	Analog Value	1402	1453	1504	1555	1606	1657	1708	1759	1810	1861	1912	1963	2014	2065	2116	2167	2218	2269	2320	2371
DIRTY_OIL_FILTER	Analog Value	1403	1454	1505	1556	1607	1658	1709	1760	1811	1862	1913	1964	2015	2066	2117	2168	2219	2270	2321	2372
HIGH_OIL_SEAL_TEMP	Analog Value	1404	1455	1506	1557	1608	1659	1710	1761	1812	1863	1914	1965	2016	2067	2118	2169	2220	2271	2322	2373
NO_CRANK_CASE_HEATER_PROOF	Analog Value	1405	1456	1507	1558	1609	1660	1711	1762	1813	1864	1915	1966	2017	2068	2119	2170	2221	2272	2323	2374
HIGH_AMPS	Analog Value	1406	1457	1508	1559	1610	1661	1712	1763	1814	1865	1916	1967	2018	2069	2120	2171	2222	2273	2324	2375
LOW_AMPS	Analog Value	1407	1458	1509	1560	1611	1662	1713	1764	1815	1866	1917	1968	2019	2070	2121	2172	2223	2274	2325	2376
HIGH_MOTOR_TEMP	Analog Value	1408	1459	1510	1561	1612	1663	1714	1765	1816	1867	1918	1969	2020	2071	2122	2173	2224	2275	2326	2377
NO_COMPRESSOR_PROOF	Analog Value	1409	1460	1511	1562	1613	1664	1715	1766	1817	1868	1919	1970	2021	2072	2123	2174	2225	2276	2327	2378
LOW_OIL_SUPERHEAT	Analog Value	1410	1461	1512	1563	1614	1665	1716	1767	1818	1869	1920	1971	2022	2073	2124	2175	2226	2277	2328	2379
PUMP_DOWN	Analog Value	1411	1462	1513	1564	1615	1666	1717	1768	1819	1870	1921	1972	2023	2074	2125	2176	2227	2278	2329	2380
LOW_DISCHARGE_PSI	Analog Value	1412	1463	1514	1565	1616	1667	1718	1769	1820	1871	1922	1973	2024	2075	2126	2177	2228	2279	2330	2381
LUBE_OIL_TEMP	Analog Value	1413	1464	1515	1566	1617	1668	1719	1770	1821	1872	1923	1974	2025	2076	2127	2178	2229	2280	2331	2382
LUBE_OIL_PSI	Analog Value	1414	1465	1516	1567	1618	1669	1720	1771	1822	1873	1924	1975	2026	2077	2128	2179	2230	2281	2332	2383
LUBE_OIL_TIME	Analog Value	1415	1466	1517	1568	1619	1670	1721	1772	1823	1874	1925	1976	2027	2078	2129	2180	2231	2282	2333	2384
REFRIGERATION_LEAK	Analog Value	1416	1467	1518	1569	1620	1671	1722	1773	1824	1875	1926	1977	2028	2079	2130	2181	2232	2283	2334	2385
LOW_REFRIGERATION_TEMP	Analog Value	1417	1468	1519	1570	1621	1672	1723	1774	1825	1876	1927	1978	2029	2080	2131	2182	2233	2284	2335	2386
TOO_MANY_PURGES	Analog Value	1418	1469	1520	1571	1622	1673	1724	1775	1826	1877	1928	1979	2030	2081	2132	2183	2234	2285	2336	2387
EXCESS_PURGING_TIME	Analog Value	1419	1470	1521	1572	1623	1674	1725	1776	1827	1878	1929	1980	2031	2082	2133	2184	2235	2286	2337	2388
PURGE_FLOAT_ERROR	Analog Value	1420	1471	1522	1573	1624	1675	1726	1777	1828	1879	1930	1981	2032	2083	2134	2185	2236	2287	2338	2389
LOW_DIFFERENTIAL_PSI_RATIO	Analog Value	1421	1472	1523	1574	1625	1676	1727	1778	1829	1880	1931	1982	2033	2084	2135	2186	2237	2288	2339	2390
LOW_SUPERHEAT	Analog Value	1422	1473	1524	1575	1626	1677	1728	1779	1830	1881	1932	1983	2034	2085	2136	2187	2238	2289	2340	2391
LOW_DISCHARGE_SUPERHEAT	Analog Value	1423	1474	1525	1576	1627	1678	1729	1780	1831	1882	1933	1984	2035	2086	2137	2188	2239	2290	2341	2392
LOST_LEG_PART_WINDING	Analog Value	1424	1475	1526	1577	1628	1679	1730	1781	1832	1883	1934	1985	2036	2087	2138	2189	2240	2291	2342	2393
HIGH_PARTS_PER_MILLION_LEAK	Analog Value	1425	1476	1527	1578	1629	1680	1731	1782	1833	1884	1935	1986	2037	2088	2139	2190	2241	2292	2343	2394
HIGH_REFRIGERATION_LEVEL	Analog Value	1426	1477	1528	1579	1630	1681	1732	1783	1834	1885	1936	1987	2038	2089	2140	2191	2242	2293	2344	2395
LOW_OIL_LEVEL	Analog Value	1427	1478	1529	1580	1631	1682	1733	1784	1835	1886	1937	1988	2039	2090	2141	2192	2243	2294	2345	2396
NO_FLOW	Analog Value	1428	1479	1530	1581	1632	1683	1734	1785	1836	1887	1938	1989	2040	2091	2142	2193	2244	2295	2346	2397
OIL_FLOW	Analog Value	1429	1480	1531	1582	1633	1684	1735	1786	1837	1888	1939	1990	2041	2092	2143	2194	2245	2296	2347	2398

BACnet Object Identifier

Alarms	BACnet Object Type	Comp. #1	Comp. #2	Comp. #3	Comp. #4	Comp. #5	Comp. #6	Comp. #7	Comp. #8	Comp. #9	Comp. #10	Comp. #11	Comp. #12	Comp. #13	Comp. #14	Comp. #15	Comp. #16	Comp. #17	Comp. #18	Comp. #19	Comp. #20
COMPRESSOR_SPEED_FAULT	Analog Value	1430	1481	1532	1583	1634	1685	1736	1787	1838	1889	1940	1991	2042	2093	2144	2195	2246	2297	2348	2399
LOW_TANDEM_SUPERHEAT	Analog Value	1431	1482	1533	1584	1635	1686	1737	1788	1839	1890	1941	1992	2043	2094	2145	2196	2247	2298	2349	2400
HIGH_TANDEM_SUPERHEAT	Analog Value	1432	1483	1534	1585	1636	1687	1738	1789	1840	1891	1942	1993	2044	2095	2146	2197	2248	2299	2350	2401
EXCESS_SURGES	Analog Value	1433	1484	1535	1586	1637	1688	1739	1790	1841	1892	1943	1994	2045	2096	2147	2198	2249	2300	2351	2402
HIGH_SUPERHEAT	Analog Value	1434	1485	1536	1587	1638	1689	1740	1791	1842	1893	1944	1995	2046	2097	2148	2199	2250	2301	2352	2403
Suction Temperature Sensor Fault	Analog Value	1435	1486	1537	1588	1639	1690	1741	1792	1843	1894	1945	1996	2047	2098	2149	2200	2251	2302	2353	2404
Discharge Temperature Sensor Fault	Analog Value	1436	1487	1538	1589	1640	1691	1742	1793	1844	1895	1946	1997	2048	2099	2150	2201	2252	2303	2354	2405
Suction Pressure Sensor Fault	Analog Value	1437	1488	1539	1590	1641	1692	1743	1794	1845	1896	1947	1998	2049	2100	2151	2202	2253	2304	2355	2406
Discharge Pressure Sensor Fault	Analog Value	1438	1489	1540	1591	1642	1693	1744	1795	1846	1897	1948	1999	2050	2101	2152	2203	2254	2305	2356	2407
Oil Pressure Sensor Sensor Fault	Analog Value	1439	1490	1541	1592	1643	1694	1745	1796	1847	1898	1949	2000	2051	2102	2153	2204	2255	2306	2357	2408
Oil Temperature Sensor Fault	Analog Value	1440	1491	1542	1593	1644	1695	1746	1797	1848	1899	1950	2001	2052	2103	2154	2205	2256	2307	2358	2409
Motor Temperature Sensor Fault	Analog Value	1441	1492	1543	1594	1645	1696	1747	1798	1849	1900	1951	2002	2053	2104	2155	2206	2257	2308	2359	2410
Evap Refrigerant Temp. Sensor Fault	Analog Value	1442	1493	1544	1595	1646	1697	1748	1799	1850	1901	1952	2003	2054	2105	2156	2207	2258	2309	2360	2411
Evap Refrigerant Level Sensor Fault	Analog Value	1443	1494	1545	1596	1647	1698	1749	1800	1851	1902	1953	2004	2055	2106	2157	2208	2259	2310	2361	2412
Oil Seal Temperature Sensor Fault	Analog Value	1444	1495	1546	1597	1648	1699	1750	1801	1852	1903	1954	2005	2056	2107	2158	2209	2260	2311	2362	2413
Pre-Oil Filter Presssure Sensor Fault	Analog Value	1445	1496	1547	1598	1649	1700	1751	1802	1853	1904	1955	2006	2057	2108	2159	2210	2261	2312	2363	2414
Circuit Leaving Water Sensor Fault	Analog Value	1446	1497	1548	1599	1650	1701	1752	1803	1854	1905	1956	2007	2058	2109	2160	2211	2262	2313	2364	2415

1.9. Network inputs to MCS-MAGNUM

The MCS-Magnum can receive changes from the network to enable or disable the Network Run/Stop, Network Target Reset (adjustments to the Cooling Target, Setpoint #1, based on Setpoint #21), Network Demand FLA, and Network Demand Steps.

The MCS-Magnum must be set up to accept these inputs. The configuration file must contain a Network Run/Stop, Network Target, Network Demand FLA, and Network Demand Steps sensors.

Magnum	BACnet ID	BACnet Name	Modbus	N2
Network Run/Stop	AV:246	Net_R/S	40201	BO:247
Network Target/Reset	AV:247	Net_Tar/Res	40202	AO:248
Network Demand/FLA	AV:248	Net_Demad_FLA	40204	AO:249
Network Demand/Steps	AV:249	Net_Demad_Steps	40205	AO:250

Note the following Information panel has a Network Run/Stop, and /or Network Target Reset sensors inputs indicated. This is an example of how MCS-Config must be setup in the General Information and Evaporator Information panels.

The sensors must be set up as follows (This is only an example)

1-1	BMS R/S	BMS RUN	Not Used	Open=OFF	OFF/ON	Not Used	Not Used	Auto
1-2	BMS TRS	BMS CW RSET	0	0	Not Used	Not Used	Not Used	Auto
1-3	BMSFLA	BMS Dmd FLA%	0	0	Not Used	Not Used	Not Used	Auto
1-4	BMSSteps	BMS Dmd Step	0	0	Not Used	Not Used	Not Used	Auto

The screenshot shows the 'General Information' configuration window. In the 'Unit Control' section, the 'Run/Stop Switch' is set to 'RUN/STOP' and the 'Network Run/Stop Sw' is also set to 'RUN/STOP'. In the 'Unit Sensors' section, the 'Demand Limit FLA %' is set to '485 FLA'. Other settings include '# of Compressors' at 2, '# of Steps' at 8, and 'Unit Type' set to 'Cooling Only'.

The screenshot shows the 'Information Panel Selector' with 'Evaporator Info' selected. The 'Evaporator Information' panel is displayed, showing 'Capacity Control' with 'Control Method' set to 'Control Zone'. The 'Pump/Fan' section has 'Pump/Fan #1A' and '#1B' set to 'Not Used'. The 'Process Control' section has 'Process Output Type' set to 'Modulating (AO)'. The 'Subcooler Valve Control' section has 'Type of Subcooler Valve in Use' set to 'None'.

1.10. MCS Capacity Control State Chart

The values exposed in the capacity state relate to the descriptions in this table.

State Number	Description
0	"UNIT IN POWER UP"
1	RESERVED
2	"NO RUN- I/O LOST"
3	"UNIT IN LOCKOUT "
4	"UNIT IS OFF "
5	"UNIT IS HOLDING "
6	"UNIT UNLOADING "
7	"UNIT IS LOADING "
8	"NO RUN-SAFETY "
9	"RUN/STOP SW OFF "
10	"SCHEDULED OFF "
11	"OFF-NO FLOW(s)"

12	RESERVED
13	"AMBIENT OFF "
14	"PROCESS HEAT OFF"
15	"UNIT IS UNLOADED"
16	"UNIT IS LOADED "
17	"OFF TMP-ICE MADE "
18	"ECONOMIZER ONLY "
19	"SWITCHING MODES "
20	"UNIT SMOKE UNLDG"
21	"UNIT OFF UNLDING"
22	"UNIT DMD UNLDING"
23	"UNIT HEAT UNLDNG"

1.11. MCS Compressor Control State Chart

The values expressed in the compressor state relate to the descriptions in this table.

State Number	Description
0	"LOST IO LOCKED"
1	"CMP LOCKED OUT"
2	"SWITCHED OFF "
3	"CMP PUMP DOWN "
4	"CMP ANTICYCLE "
5	"CMP OFF/READY "
6	"OIL PMP LUBING"
7	"CMP IS RUNNING"
8	"CMP UNLOADED "
9	"UNLD1/HGBP OFF"
10	"PART LOADED "
11	"CMP IS HOLDING"
12	"CMP IS LOADING"
13	"CMP IS UNLDING"
14	"CMP IS AT 100%"
15	"FAST UNLOADING"
16	"LO SUCT UNLOAD"
17	"LO SUCT HOLD "
18	"HI DISC UNLOAD"
19	"HI DISC HOLD "

State Number	Description
20	"SAFETY TRIPPED"
21	"LO TEMP UNLOAD"
22	"LO TEMP HOLD "
23	"HI AMP HOLD "
24	"HI DIS TMP HLD"
25	"CMP IS AT 40% "
26	"CMP IS AT 70% "
27	"HI WATER HOLD "
28	"EXTRA 70% STEP "
29	"OFF-LO OIL TMP "
30	"HI AMP UNLDING "
31	"DEF PREPMP OUT "
32	"DEFROSTING "
33	"DEF PUMP DOWN "
34	"HI TEMP UNLOAD "
35	"HI TEMP HOLD "
36	"SCROLL STEP1 "
37	"SCROLL STEP2 "
38	"SCROLL STEP3 "
39	"SCROLL STEP4 "

1.12. MCS-MAGNUM BMS PROTOCOLS

The following Protocols are available with the Magnum. Changes can be made to the settings using the Keypad or can be made using MCS-CONNECT SERVICE WINDOW.

1. BACnet IP
2. MCS PROTOCOL
3. MODBUS RTU PROTOCOL
4. ETHERNET PROTOCOL (this protocol is always active)
5. MODBUS IP (this protocol is always active)

1.12.1 BACnet OVER IP PROTOCOL

The BACnet DEVICE ID is a five-digit number. The first three digits are based on MCS's BACnet Vendor ID 181, and the last two are set by the BACnet/MS/TP address.

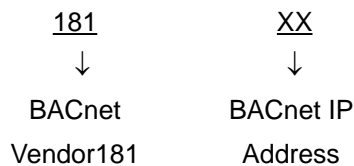

In case the end user would like to set up an ID other than 181-XX, there is an extended BACnet setting that can only be set in MCS Config.

The following changes can be made using the Keypad or can be made using **MCS-CONNECT SERVICE WINDOW**.

The **BACnet IP** address can be verified and changed (with the proper authorization code) from the Keypad/LCD. The following steps will display the BACnet IP Network address, and the the TCP/IP port:

- Press the Menu key, select Serv Tools, and then press the Enter key.
- Use **↑** arrow to **BACnet Setting** then press Enter.
- Select address then press Enter. Change the address so it matches the last two digits of the device ID then press Enter.
- Use **↓** arrow to tab to the TCP/IP address.
- Select address then press Enter. Change the address and port to match your device.

1.12.2 ETHERNET NETWORK PROTOCOL

The following steps will display the **ETHERNET NETWORK** settings:

If you are going to manually assign the IP Address, Subnet Mask, and Default Gateway.

- Press the Menu key, select Serv Tools, and then press the Enter key.
- Select Ethernet Network then press Enter.
- Set "DYNAMIC IP" to NO.
- Set the "IP Address".
- Set the "Subnet Mask".
- Set "Default Gateway".
- Reset Magnum for change to take effect.

If you are going to let your network assign the IP Address, Subnet Mask, and Default Gateway.

- Press the Menu key, select Serv Tools, and then press the Enter key.

- Select Ethernet Network then press Enter.
- Set “DYNAMIC IP” to YES.
- Connect the MCS-Magnum to the network and power up the board.

1.12.3 MODBUS RTU PROTOCOL

The Modbus RTU address can be verified and changed (with the proper authorization code) from the keypad/LCD or can be made using MCS-CONNECT SERVICE WINDOW..

The following steps will display the Modbus RTU Network address, and the Baud Rate:

- Press the Menu key, select Serv Tools, and then press the Enter key.
- Select RS485 Network then press Enter.
- Select Protocol then press Enter. Change the protocol to Modbus RTU.
- Select address then press Enter. Change the address then press Enter.
- Select Baud then press Enter. Set the baud rate then press Enter.
- Connect the communication wires to the TX RS485 three-position terminal located above the Ethernet connector.
- Reset Magnum for change to take effect.

1.12.4 MODBUS TCP/IP PROTOCOL

This protocol is always active.

Make sure the MCS-Magnum network settings are set correctly.

If you are going to manually assign the IP Address, Subnet Mask, and Default Gateway.

Press the Menu key, select Serv Tools, and then press the Enter key.

- Select Ethernet Network then press Enter.
- Set “DYNAMIC IP” to NO.
- Set the “IP Address”.
- Set the “Subnet Mask”.
- Set “Default Gateway”.
- Reset Magnum for change to take effect.

If you are going to let your network assign the IP Address, Subnet Mask, and Default Gateway.

- Press the Menu key, select Serv Tools, and then press the Enter key.
- Select Ethernet Network then press Enter.
- Set “DYNAMIC IP” to YES.
- Connect the MCS-Magnum to the network and power up the board.

1.13. PROTOCOLS USING MCS-BMS-GATEWAY

The MCS-BMS-GATEWAY is a microprocessor based communication device that provides translation from BACnet IP to BACnet MS/TP, or Johnson Control N2.

Information that can be transmitted includes the status of control points, alarm information, digital inputs, analog inputs or setpoints.

For more information on the MCS-BMS-GATEWAY please go to www.mcscontrols.com.

Chapter - 2. NETWORK PROTOCOLS

Network protocols are formatting rules that specify how data is sent and received between devices. Protocols are necessary for devices to interact with each other.

2.1. Protocols MCS controllers support:

1. BACnet
2. MODBUS RTU
3. ETHERNET
4. MCS
5. JOHNSON N2

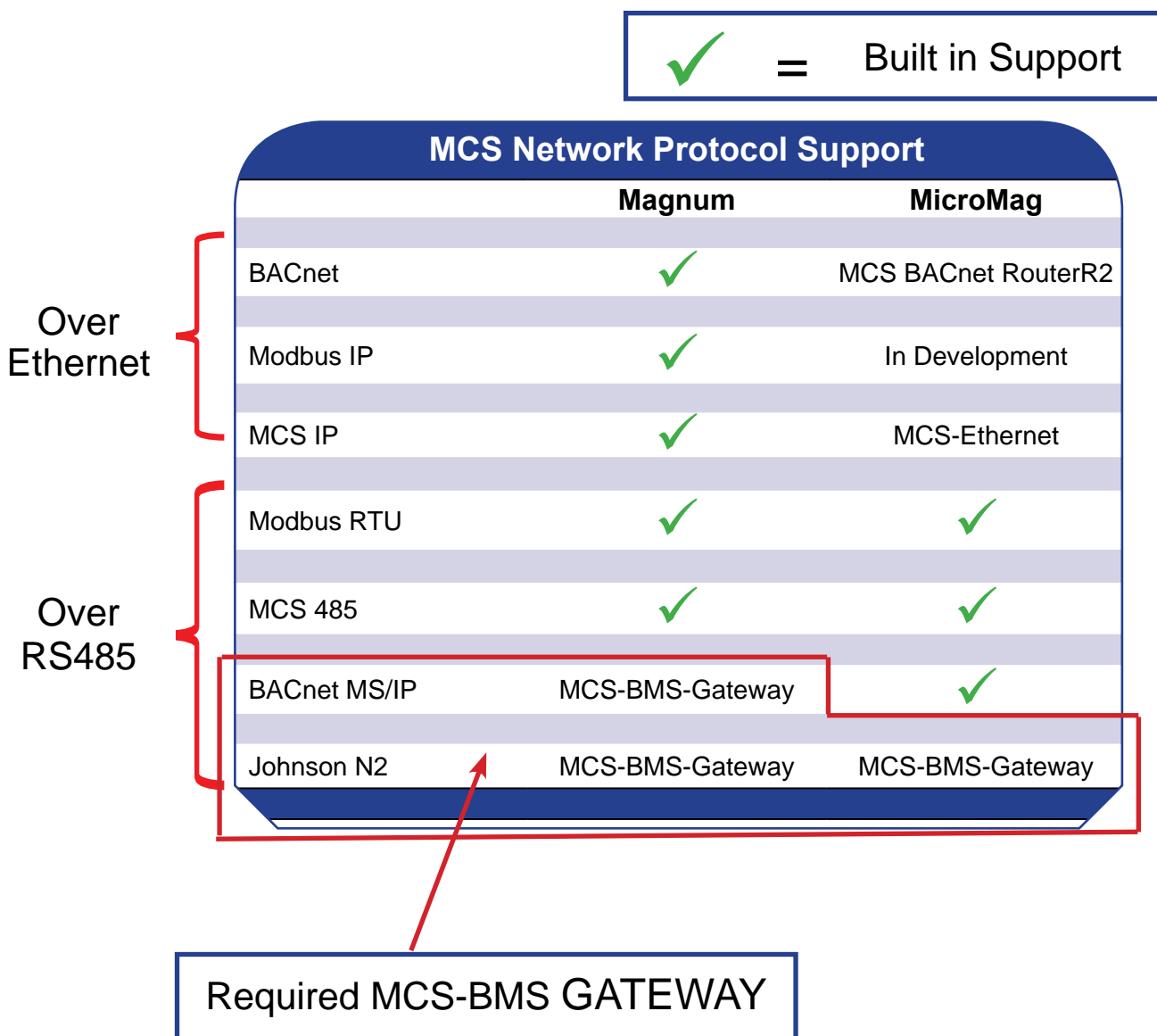

2.2. MCS-MAGNUM USING RS-485

Using the RS485, the MCS-Magnum can be connected to the BMS (Modbus RTU or MCS 485)

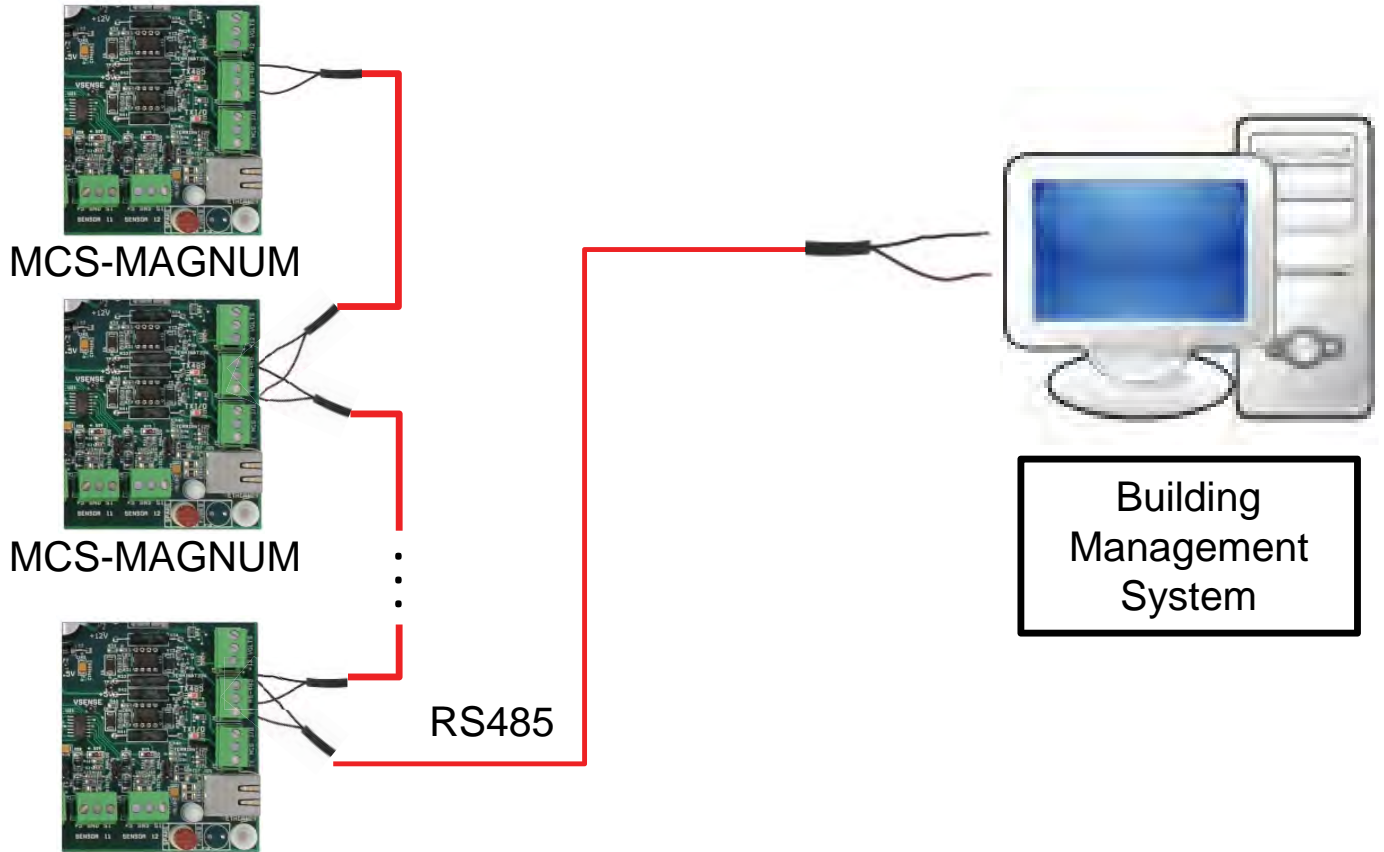

2.3. Wiring Multiple MCS Controllers

- Using the RS485, the network must be wired controller to controller
- Star configurations not allowed
- Up to 30 controllers can be wired together

Wiring Multiple MCS Controllers Using RS-485

Using the RS485, the MCS-Magnum can be connected to the BMS (Modbus RTU or MCS 485)

- Using the RS485, the network must be wired controller to controller.
- Star configurations not allowed.
- Up to 30 controllers can be wired together.



The RS232 cannot be used with different protocols when the RS485 is used.

MCS-MAGNUM #1
or MCS-MicroMag

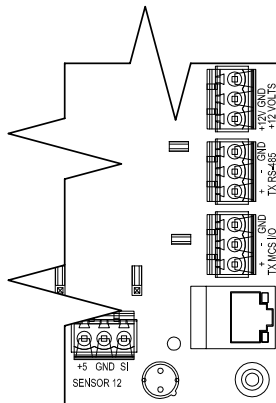

MCS-MAGNUM #2
or MCS-MicroMag

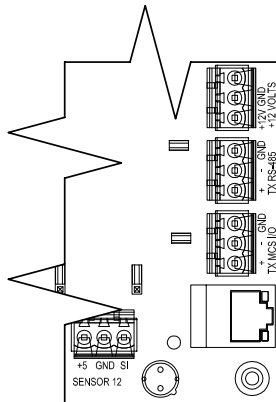

MCS-MAGNUM #3
or MCS-MicroMag

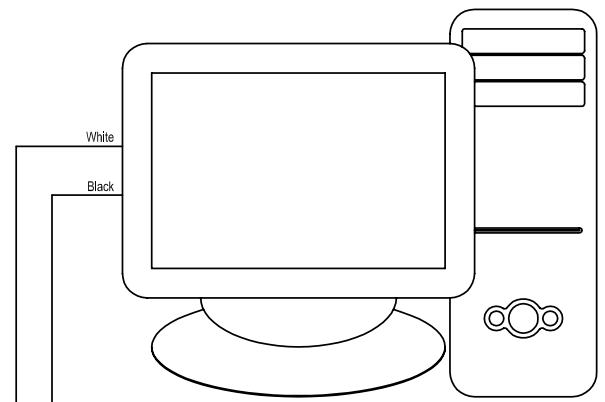
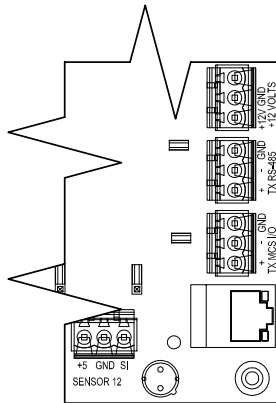

Building
Management
System

2.4. MCS-MAGNUM USING ETHERNET

- Using the Ethernet, the MCS-Magnum can be connected to:
- BMS (BACnet IP or Modbus IP)
- MCS-Touch (MCS-Connect)
- PC (MCS-Connect)
- Internet access through router (which allows connection via MCS-Connect from anywhere)

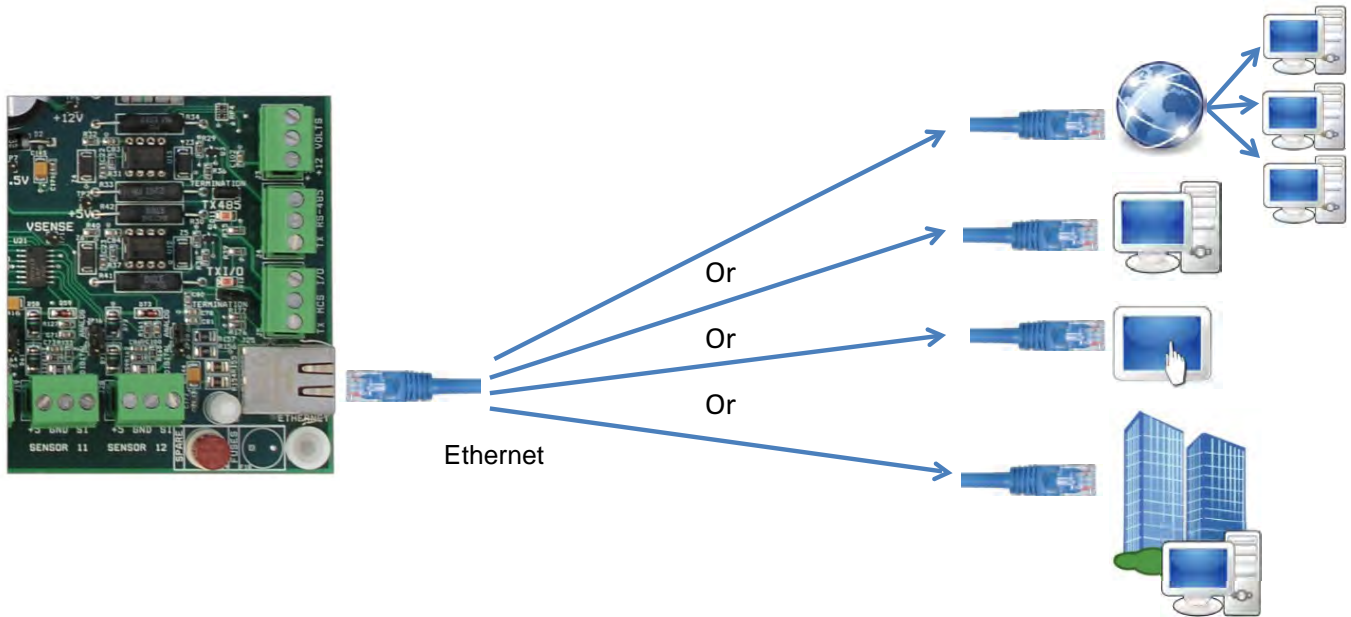

2.5. EXAMPLE NETWORK

2.5.1 Standalone MCS-Magnum

- MCS-Touch
- BMS (Johnson N2 or BACnet MS/TP)
- Internet Access

2.5.2 MULTIPLE MCS-MAGNUM ENCLOSURES

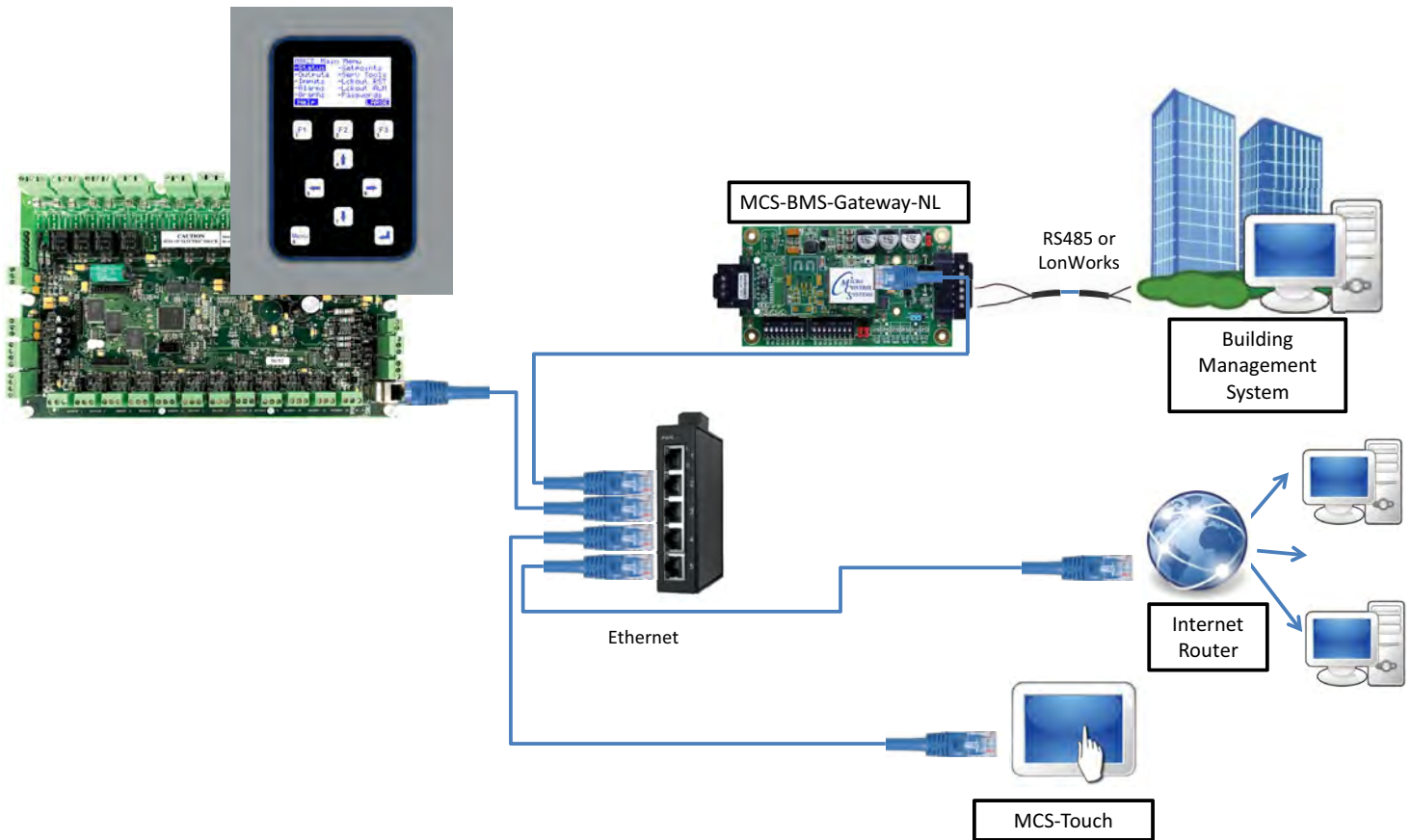

- Internet Access
- BMS (BACnet IP or Modbus IP)

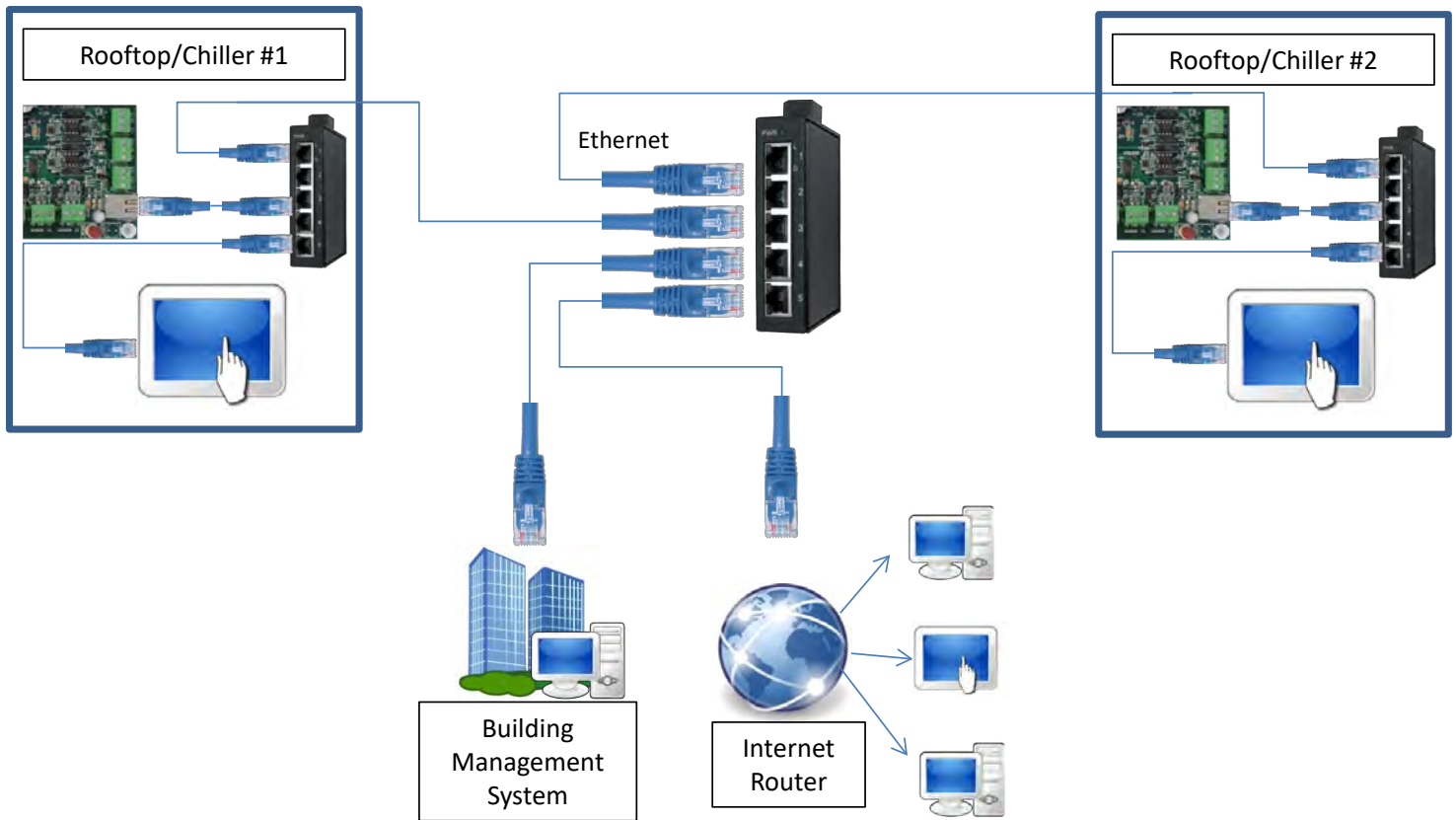

2.6. MULTIPLE MCS-MAGNUM BMS RS485 WIRING DIAGRAM

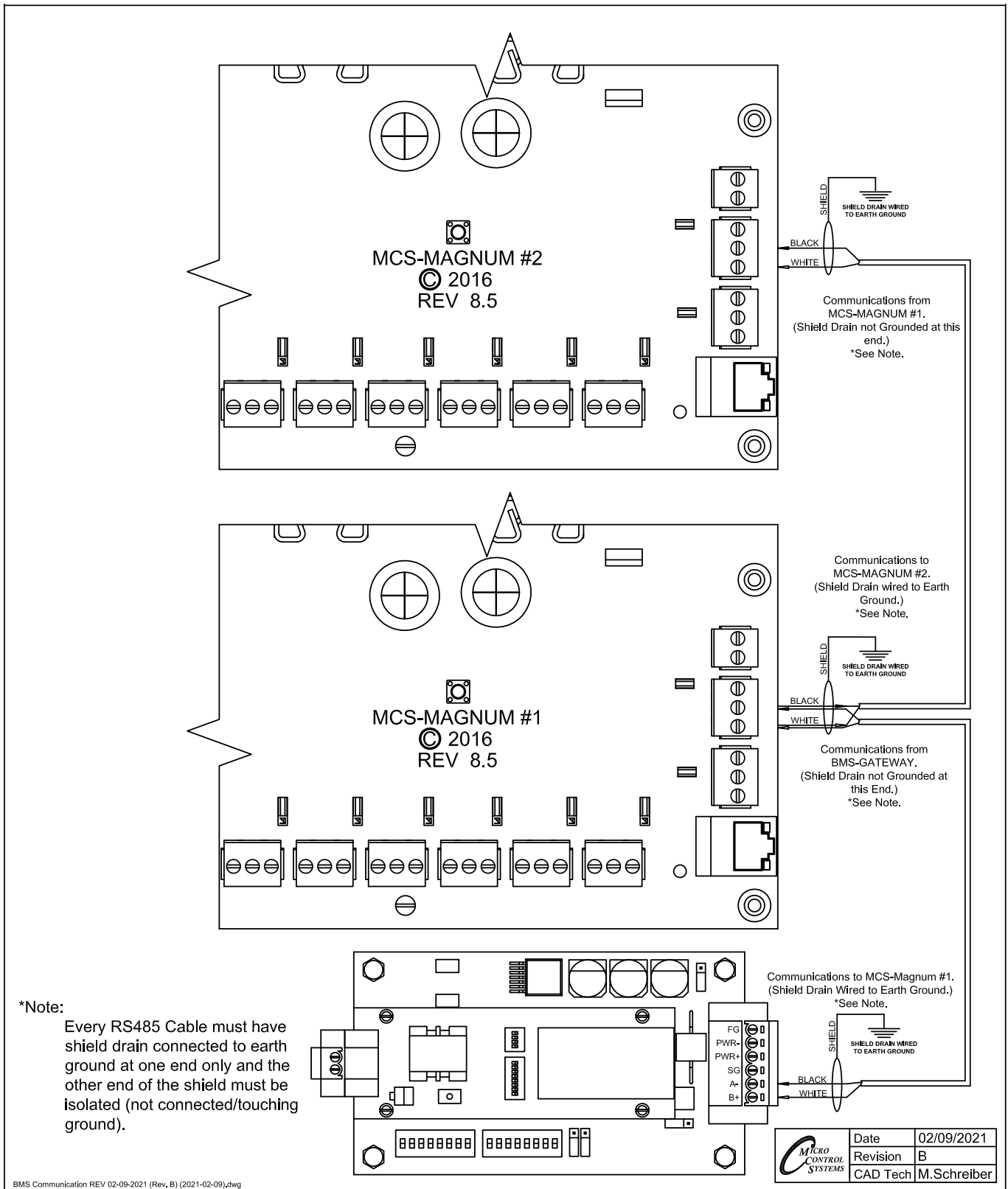

Chapter - 3. FIELDSEVER TOOLBOX

Revision: 2.A

The latest update to the user interface utility called FieldServer Toolbox has been introduced. This updated utility is available on the web for all FieldServer Gateways and enables users to easily:

1. Search the local network for any connected FieldServers.
2. Select the FieldServer and launch either the current user-friendly browser-based interface to help set-up, configure and diagnose the FieldServer.

NOTE: The ProtoCast gateway is not supported by the FS Toolbox. For gateways updated with FieldSafe, diagnostic captures cannot be taken with the FieldServer Toolbox but has been integrated into the FS-GUI configuration page.

The following information is viewable for connected FieldServers found by the FieldServer Toolbox:

DEVICES – Lists the device name.

IP ADDRESS – Shows the IP Address of the listed device.

MAC ADDRESS – Shows the MAC Address of the listed device.

FAVORITE – Click to mark this as a favorite device. The device information will show whether the device is found or not.

CONNECTIVITY – The light shows the level of connectivity for the device. Green is full connectivity. Yellow is limited connectivity. Blue is limited IP connectivity. And red is connectivity lost.

BUTTONS – These buttons allow multiple functions. The Connect button jumping straight into a device's FS-GUI or Web Configurator page via default Internet browser. The Heartbeat button allows taking diagnostics for the device.

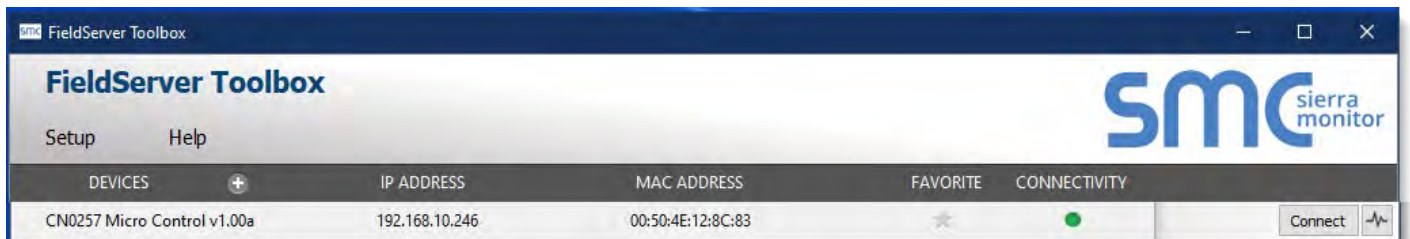

NOTE: For detailed descriptions on any of these items or additional information check the help menu.

Download the MCS-BMS-GATEWAY - FS Toolbox at:

<https://mcsccontrols.com/communications.html> - "FieldServer Toolbox-1.08aC-Setup.exe"

FieldServer Graphical User Interface (FS-GUI)

FieldServer Gateways come with the web-based FS-GUI making it easy to check the status, configure and diagnose your FieldServer. Information such as network settings, node information, map descriptors, and transfer of files. The web browser interface can even be set up with your own logo and background if desired.

Each of the pages on the FS-GUI includes specific FieldServer information and features described below.

NOTE: Click the Help button at the bottom of any page to view the Keyboard Shortcut and General Navigation list.

Home

Allows the user to check the status of the FieldServer gateway, including the configuration code, version, memory, gateway type and more. Under “Settings” the user has access to important network information.

NOTE: The “System Restart” button at the bottom of the page is used to restart the FieldServer gateway (only on the Home page).

The screenshot displays the SMC Sierra Monitor interface. On the left is a navigation menu with 'Demo' selected. The main area shows the 'Demo' status page with tabs for 'Status', 'Settings', and 'Info Stats'. The 'Status' tab is active, displaying a table of system parameters and their values.

Name	Value
Driver_Configuration	DCC000
DCC_Version	V6.05p (A)
Kernel_Version	V6.50b (B)
Release_Status	Normal
Build_Revision	4.42.5-1-gff9eb3c6c0
Build_Date	2019-05-29 15:43:14 +0200
Platform_Name	ProtoAir_2RS485_ARMv7
BIOS_Version	4.1.0
FieldServer_Model	FPC-N54
Serial_Number	19102TB001PCR
Carrier_Type	-
Data_Points_Used	40
Data_Points_Max	1500
Application Memory:	

At the bottom of the page, there are buttons for 'Home', 'HELP (F1)', 'Contact Us', 'System Restart', 'System Time Synchron', and 'Reset Cycle Times'.

About

Allows the user to check current firmware of the FieldServer gateway plus version identification of the interface and skin, plus contact information. Skin is either the default FieldServer template or it can be a specific template specified by the OEM customer.

Setup

Select “File Transfer” to upload files to the FieldServer gateway including configuration files, firmware upgrades and more. Select “Network Settings” to access and modify network connection.

View

Select “Connections” to view activity of devices connected to the FieldServer gateway ports.

Select “Data Arrays” to view the Data Arrays setup in the gateway and the user can click on the specific Data Array for detailed information.

Select “Nodes” to view the Nodes setup in the gateway and the user can click on the specific node for Node detailed information. On the Nodes details page tabs across the top allow access to settings, status, info stats and error stats.

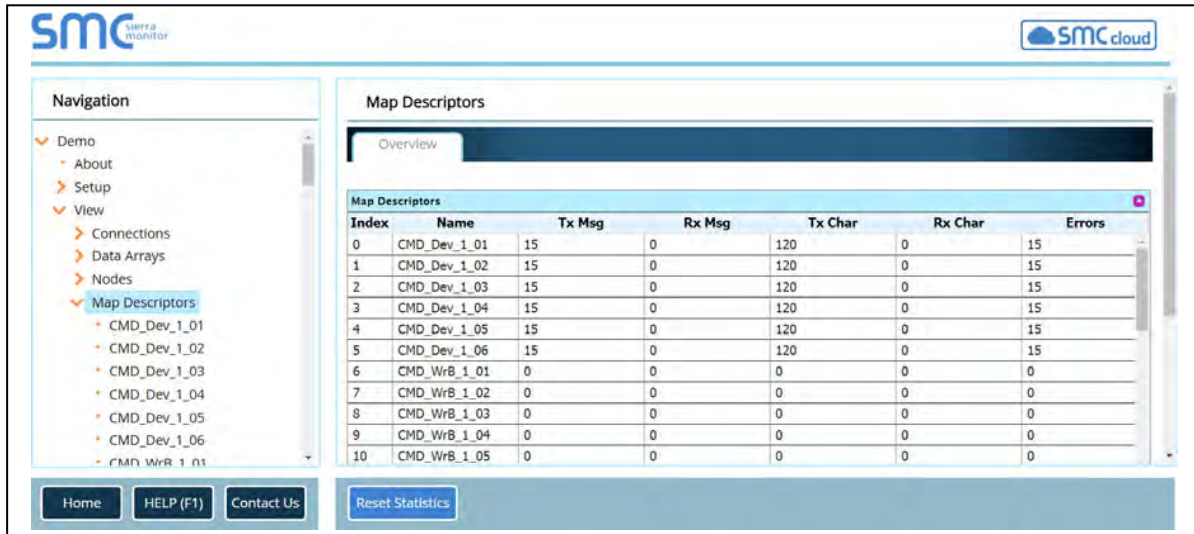

Select “Map Descriptors” to view the Map Descriptors setup in the gateway and clicking on the specific map descriptor will access the Map Descriptors detail page. Again, tabs across the top of the page provide quick access to settings, status, info stats, and error stats.

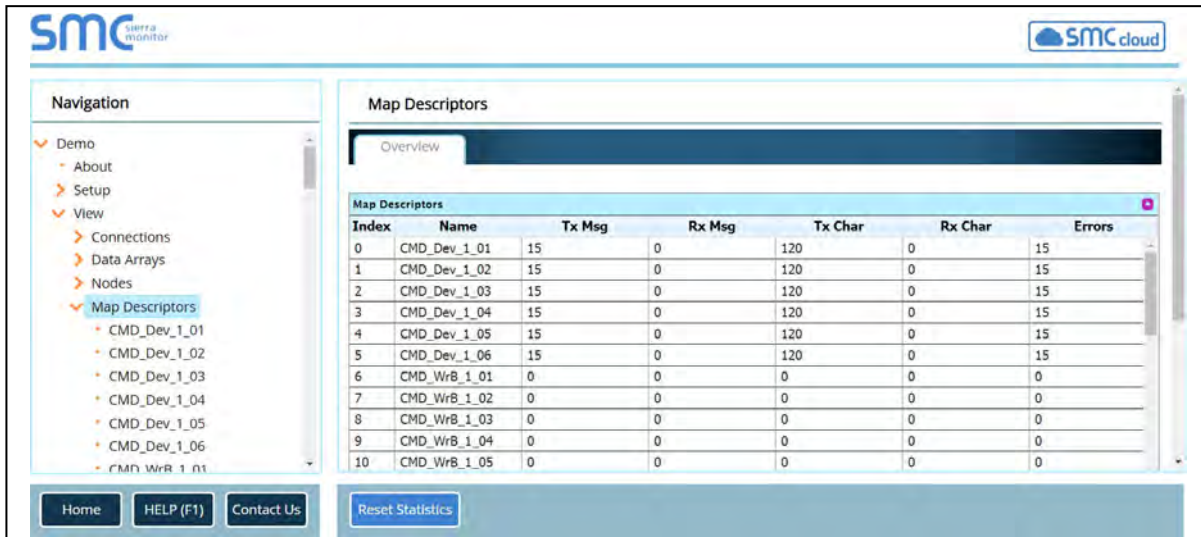

User Messages

Allows access to error messages, info messages and driver messages.

Diagnostics

Used to create diagnostics captures to assist technical support. Allows capture of Ethernet or Wi-Fi connections.

Chapter - 1. Introduction

MCS-BMS-GATEWAY-NL is an external, high performance Building Automation multi-protocol gateway that has been pre programmed to support BACnet¹ MS/TP, Metasys² N2 by JCI, and Modbus IP to RTU. Configurations for the various protocols are stored within the MCS-BMS-GATEWAY-NL and are selectable via DIP switches for fast and easy installation. It is not necessary to download any configuration files to support the required applications.

This document provides the necessary information to facilitate installation of the MCS-BMS-GATEWAY-NL-.

1.1. BTL Mark – BACnet Testing Laboratory



The BTL Mark on the MCS-BMS-GATEWAY-NL is a symbol that indicates to a consumer that a product has passed a series of rigorous tests conducted by an independent laboratory which verifies that the product correctly implements the BACnet features claimed in the listing. The mark is a symbol of a high-quality BACnet product. Go to <http://www.BACnetinternational.net/btl/> for more information about the BACnet Testing Laboratory.

1.2. UL and RoHS Certification



File No: 916 CE & RoHS

The MCS-BMS GATEWAY is approved across a variety of standards, including the UL 916, CE, and RoHS.



¹ BACnet is a registered trademark of ASHRAE

² Metasys is a registered trademark of Johnson Controls Inc.

Chapter - 2. Quick Start Guide

1. Record the information about the unit. (Section 3.1)
2. Set the device's BACnet MSTP serial settings (protocol address, baud rate) (Section 3.2)
3. Select a stored configuration and set field protocol MAC address/Node-ID/Device Instance, and baud rate. (Section 3.3)
4. Connect MCS-BMS-GATEWAY-NL's 6 pin RS-485 connector to the RS-485 network that is connected to each of the devices. (Section 4.2)
5. Connect MCS-BMS-GATEWAY-NL FPC-C34's 2 pin LonWorks port to the Field Protocol cabling **if connecting by LonWorks** (Section 4.7)
6. Connect Power to MCS-BMS-GATEWAY-NL's 6 pin connector. (Section 4.8)
7. Use the MCS-BMS-GATEWAY-NL's embedded tool which is accessed with a browser, referred to in this manual as the Web Configurator, to change the IP Address. No changes to the configuration file are necessary.

Part Number	FPC-C34
Serial No.....	
PROTOCOL USED	BACnet MS/TP, N2, Modbus IP to RTU
I/P ADDRESS MCS-BMS-GATEWAY-NL	192-168-18-XXX(range. 201-250)
IP ADDRESS MCS-CONTROLLER	192-168-18-XXX (see label on MCS-BMS-GATEWAY-NL)
SUBNET ADDRESS.....	255-255-255-0
MAGNUM BACnet PORT.....	47808
BAUD RATE	19,200 Default
BACnet ADDRESS USED	181,XX (18100 plus Node setting 'A' Bank DIP Switches)

TERMS USED:

BACnet - communications protocol for **BUILDING AUTOMATION AND CONTROL NETWORKS**

MAC ADDRESS - **MEDIA ACCESS CONTROL ADDRESS** (MAC address)

BACnet MSTP - **COMMUNICATION PROTOCOL FOR BUILDING AUTOMATION TRANSPORTED BY ETHERNET**

Metasys® N2 - **COMMUNICATION PROTOCOL FOR BUILDING AUTOMATION WITH JOHNSON CONTROLS**

Chapter - 3. Setup for MCS-BMS-GATEWAY-NL

3.1. Record Identification Data

Each MCS-BMS-GATEWAY-NL has a unique part number located on the side or the back of the unit. This number should be recorded, as it may be required for technical support. The numbers are as follows:

Model	Part Number
MCS-BMS-GATEWAY-NL FPC-C34	FPC-C34

Figure 1: MCS-BMS-GATEWAY-NL Part Numbers

- FPC-ED4 units have the following 2 ports: Ethernet + RS-485.

3.2. Configuring Device Communications

3.2.1 Set COM settings on all Devices Connected to the MCS-BMS-GATEWAY-NL

- Set up all devices on the same subnet as the MCS-BMS-GATEWAY-NL and the configuration PC.
- All of the connected serial devices MUST have the same Baud Rate, Data Bits, Stop Bits, and Parity settings as the MCS-BMS-GATEWAY-NL.
-

3.2.2 Set IP Address for each MCS-MAGNUM connected to the MCS-BMS-GATEWAY-NL

The device needs to be on the same IP subnet as the MCS-BMS-GATEWAY-NL and the configuration PC.

Record the following MCS-MAGNUM information to start the setup:

IP Address

MCS-MAGNUM BACnet Device ID

Set MCS-MAGNUM BACnet port to **47808 in MCS-CONFIG**

- For Windows XP:

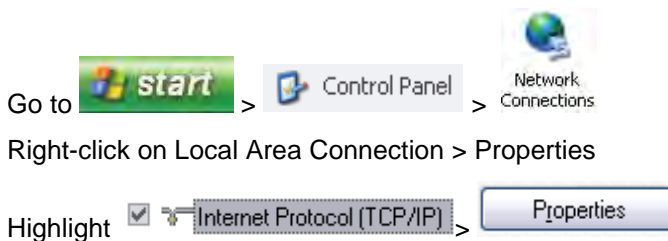

- For Windows 7 or later:

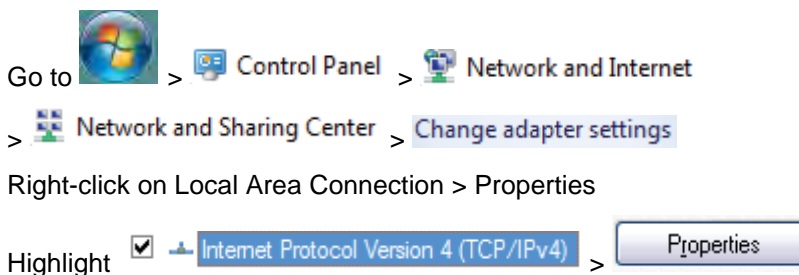

- For Windows XP and Windows 7, select: Use the following IP Address

Use the following IP address:

IP address:

Subnet mask:

Default gateway:

- Click twice

3.3. BMS Network Settings:

- Selecting Stored Configurations, Setting the MAC Address, Device Instance, and Baud Rate
- Selecting Configuration Files for Devices: “S” Bank DIP Switches S0 – S3

The S bank of DIP switches (S0 - S3) are used to select and load a configuration file from a group of pretested/preloaded configuration files which are stored in the MCS-BMS-GATEWAY-NL FPC-ED4.

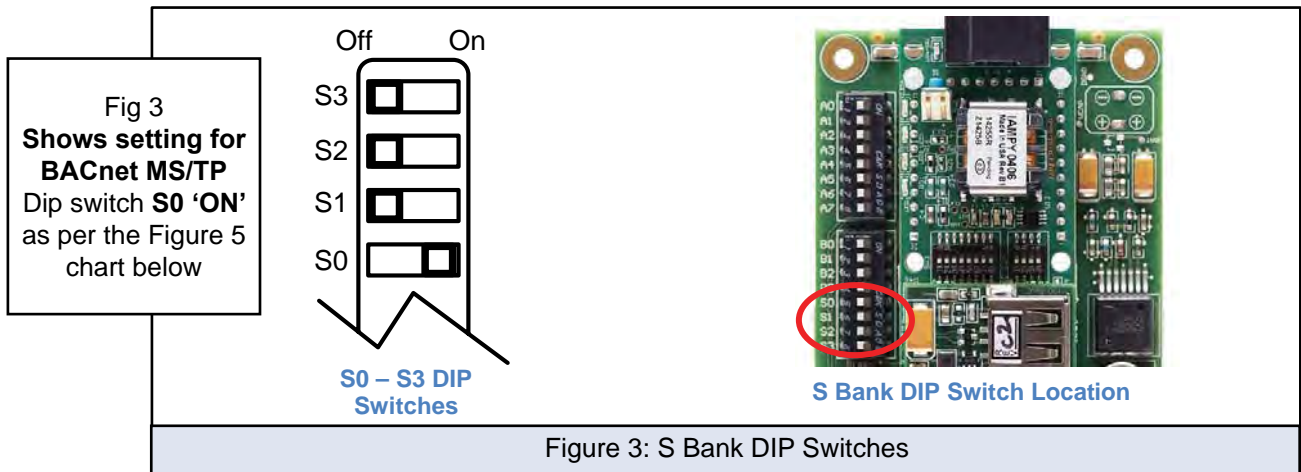

NOTE: S0 - S3 DIP Switches sets the Protocol: BACnet MS/TP, OR JOHNSON N2



NOTE: When setting DIP Switches, please ensure that power to the board is OFF.

3.3.1 BACnet MS/TP, N2 and Modbus IP to RTU

The following chart describes S0 - S3 DIP Switch configuration settings for MCS-BMS-GATEWAY-NL to support BACnet® MS/TP, Metasys® N2 by JCI and Modbus IP to RTU.

MCS-BMS-GATEWAY-NL	MCS-BMS-GATEWAY-NL Bank DIP Switches			
Profile – MCS-BMS-GATEWAY-NL RER	S0	S1	S2	S3
BACnet MS/TP	On	Off	Off	Off
N2	Off	On	Off	Off
Modbus IP to RTU	On	On	Off	Off

Figure 5 Protocol Selection Switch Tables

3.3.2 BACnet MS/TP: Setting the MAC Address for BMS Network

Only 1 MAC address is set for MCS-BMS-GATEWAY-NL regardless of how many devices are connected to MCS-BMS-GATEWAY-NL.

Set the BACnet MS/TP MAC addresses of the MCS-BMS-GATEWAY-NL to a value between 1 to 127 (MAC Master Addresses); this is so that the BMS Front End can find the MCS-BMS-GATEWAY-NL via BACnet auto discovery.

NOTE: Never set a BACnet MS/TP MAC Address from 128 to 255. Addresses from 128 to 255 are Slave Addresses and can not be discovered by BMS Front Ends that support auto discovery of BACnet MS/TP devices.

Set DIP switches A0 – A7 to assign MAC Address for BACnet MS/TP for the MCS-BMS-GATEWAY-NL FPC-C34.

Please refer to Appendix A.1 for the complete range of MAC Addresses and DIP switch settings.



NOTE: When using Metasys N2 and Modbus TCP/IP, the 'A' Bank of DIP switches are disabled and not used. They should be set to OFF.

NOTE: When setting DIP Switches, please ensure that power to the board is OFF.

3.3.3 BACnet MS/TP and BACnet/IP: Setting the Device Instance

- The 'A' Bank of DIP switches are used for two purposes:
 - For BACnet MS/TP, they are used to set the BACnet MS/TP MAC address (Section 3.3.2)
 - For both BACnet MS/TP and BACnet/IP, they are also used to determine the BACnet Device Instance values
- The BACnet Device Instance can range from 1 to 4,194,303.
- The BACnet device instances will be calculated by taking the Node Offset (default is 18100) found in Web Configurator and adding it to the value of the 'A' Bank DIP switches.

When more than one device is connected to the MCS-BMS-GATEWAY-NL, the subsequent BACnet Device Instance values will be sequential from the first/previous device.

For example:

- Given that Device Instance = Node_Offset + A Bank DIP switch value = Default Node_Offset value = 18150 = 'A' Bank DIP switch value = 03 (as per Appendix A.10 DIP Switch Setting)
- Then the Device Instance values for the devices are: = Device 1 Instance = 18153 = Device 2 Instance = 18154

3.3.4 Metasys N2: Setting the Node-ID

- Set DIP switches A0 – A7 to assign a Node-ID for Metasys N2 to the MCS-BMS-GATEWAY-NL.
- Node-ID's range from 1-255.
- Refer to Appendix A.10 for the full range of addresses for setting Node ID.

3.3.5 BACnet MS/TP: Setting the Serial Baud Rate for BMS Network

DIP Switches B0 – B3 can be used to set the serial baud rate to match the baud rate required by the Building Management System for BACnet MS/TP.

- The baud rate on MCS-BMS-GATEWAY-NL for Metasys N2 is set for 9600. DIP Switches B0 – B3 are disabled for Metasys N2.

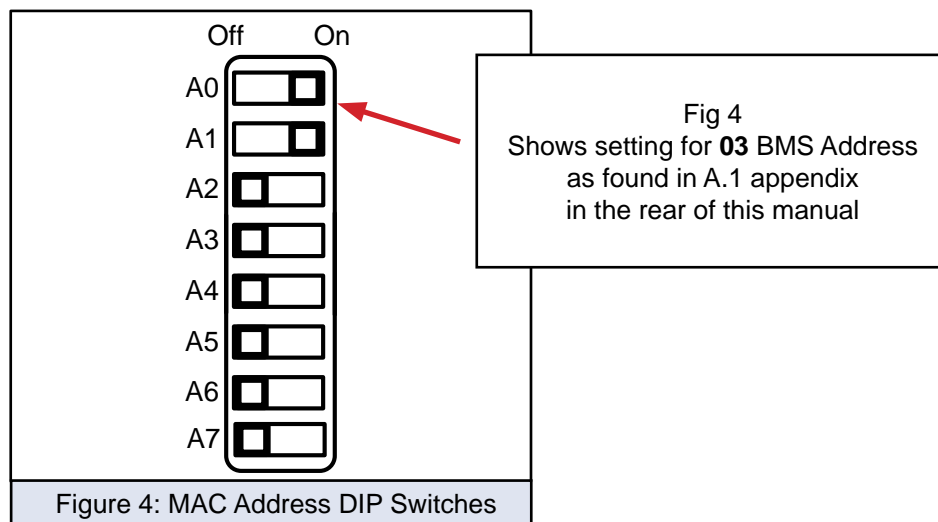
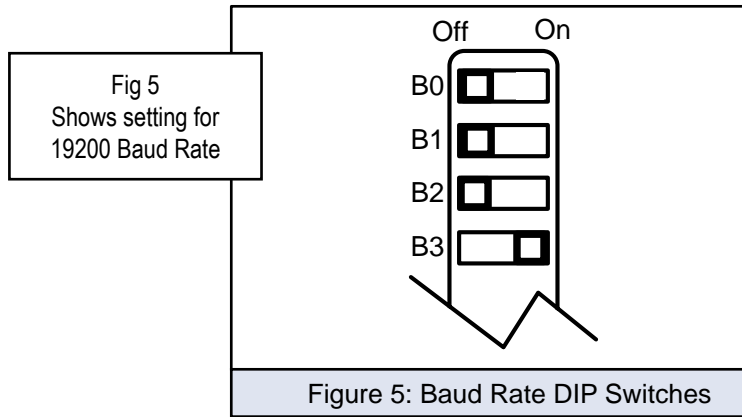



NOTE: When setting DIP Switches, please ensure that power to the board is OFF.

3.3.5.1. Baud Rate DIP Switch Selection

Baud	B0	B1	B2	B3
Auto	Off	Off	Off	Off
110	On	Off	Off	Off
300	Off	On	Off	Off
600	On	On	Off	Off
1200	Off	Off	On	Off
2400	On	Off	On	Off
4800	Off	On	On	Off
9600	On	On	On	Off
19200	Off	Off	Off	On
20833	On	Off	Off	On
28800	Off	On	Off	On
38400	On	On	Off	On
57600	Off	Off	On	On
76800	On	Off	On	On
115200	Off	On	On	On

Chapter - 4. Interfacing MCS-BMS-GATEWAY-NL to Devices

4.1. MCS-BMS-GATEWAY-NL Connection Ports

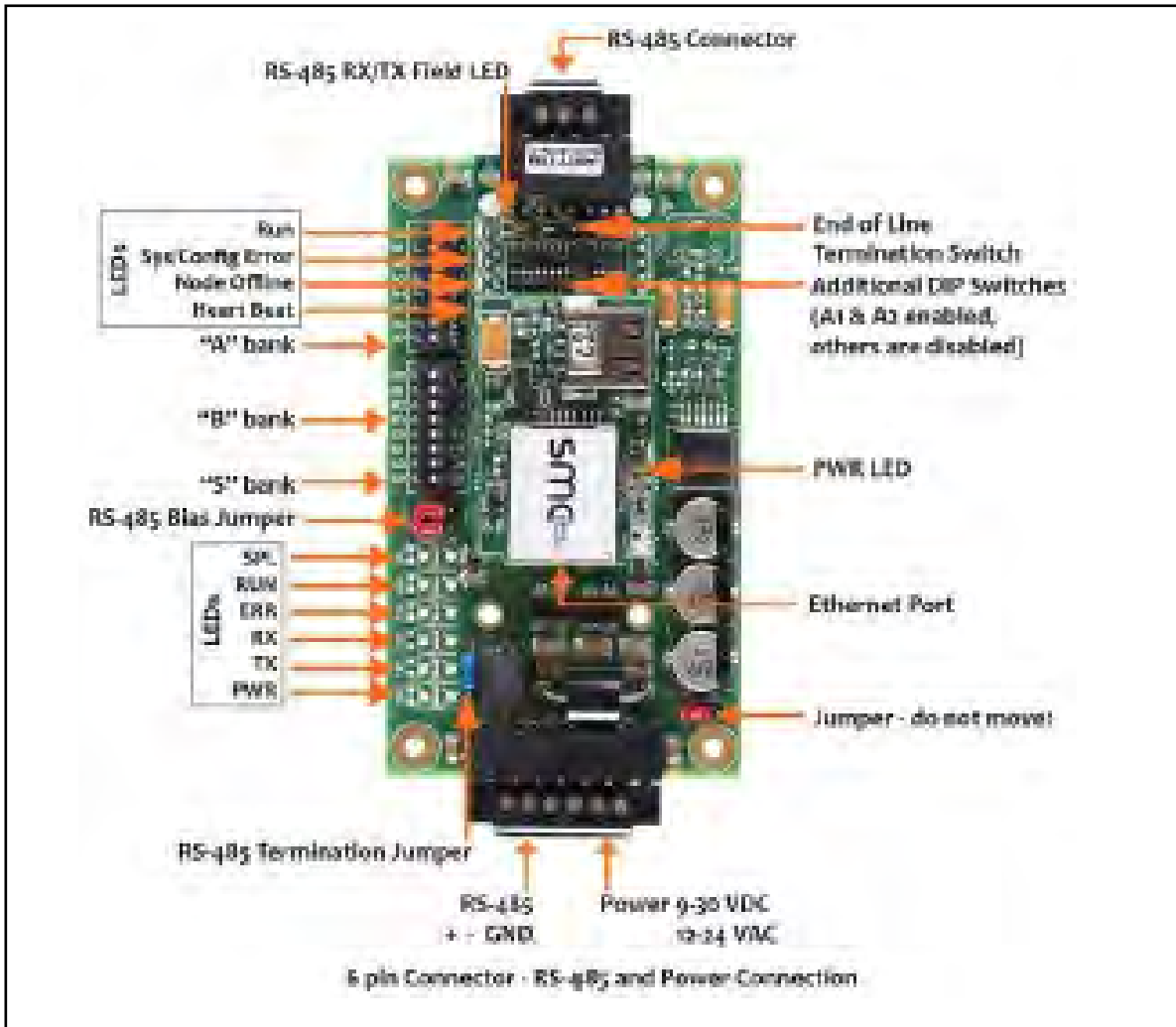
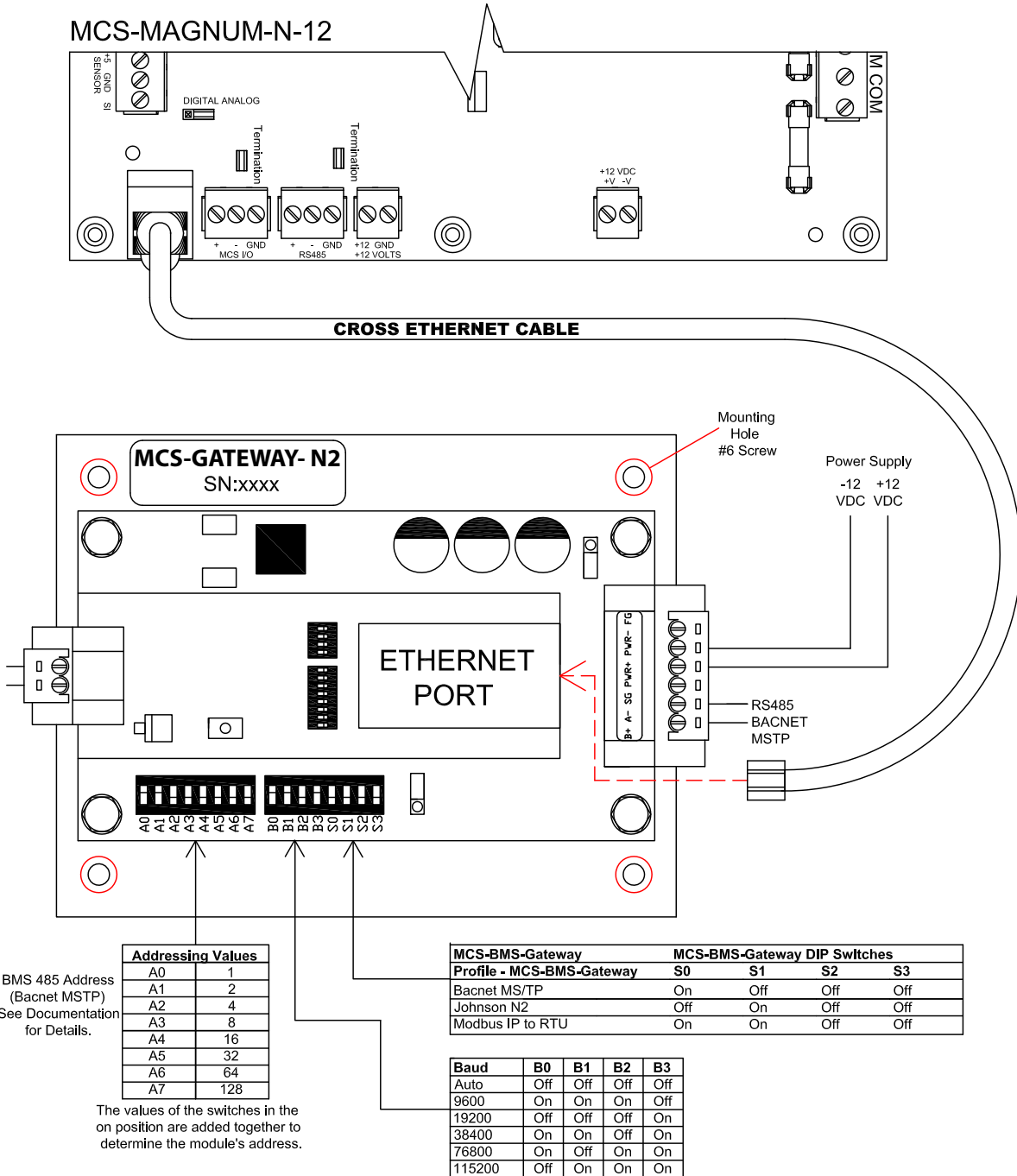

Figure 7: MCS-BMS-GATEWAY-NL

4.2. Wiring diagram for connecting the MCS-Magnum

MCS-BMS-GATEWAY-NL to MCS-MAGNUM-N-12

Mounting & Wiring Diagram



5580 Enterprise Pkwy, Fort Myers, FL 33905 USA
 Phone: (239) 694 0089 - Fax: (239) 694 0031
 www.mcscontrols.com - support@mcscontrols.com

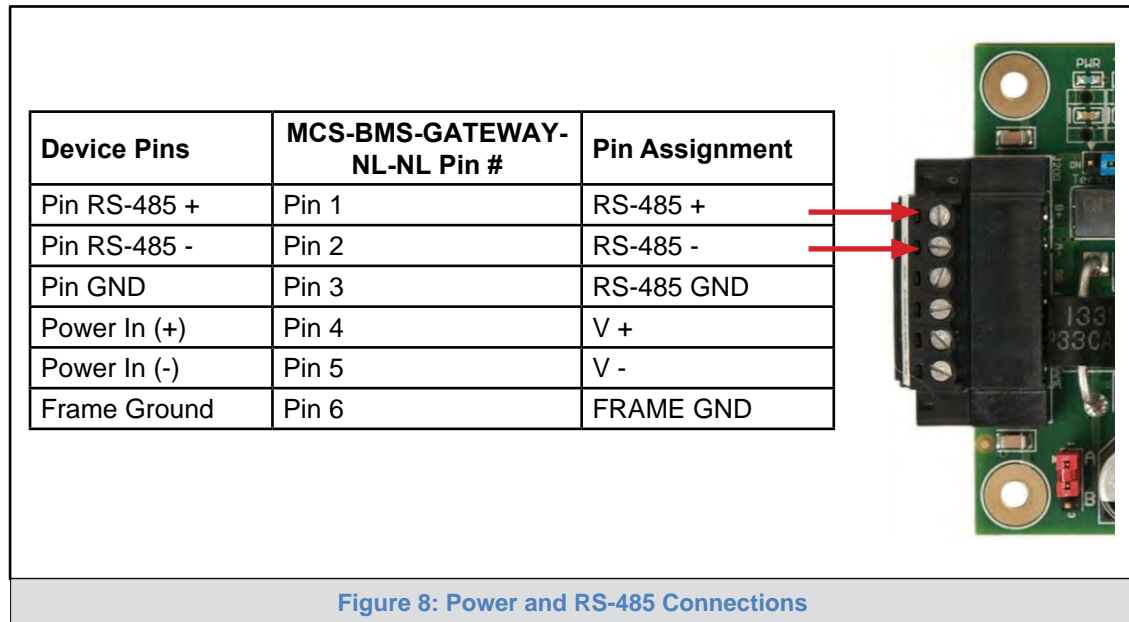

Figure 7 - Gateway to RS-485 wiring

4.3. Device Connections to MCS-BMS-GATEWAY-NL-NL

MCS-BMS-GATEWAY-NL-NL 6 Pin Phoenix connector for RS-485 Devices.

- Pins 1 through 3 are for RS-485 devices.
- The RS-485 GND (Pin 3) is not typically connected
- Pins 4 through 6 are for power. Do not connect power (wait until Section 3.4).



4.4. MCS-MAGNUM Address Settings

The MCS-BMS-GATEWAY-NL is connected to the MCS-MAGNUM via Ethernet . The BACnet Device ID and the IP address of the MCS-MAGNUM must be setup properly to enable successful communications between the MCS-BMS-GATEWAY-NL and the MCS-MAGNUM.

The MCS-MAGNUM BACnet DEVICE ID must be set to the address specified on the MCS-BMS-GATEWAY-NL's label).

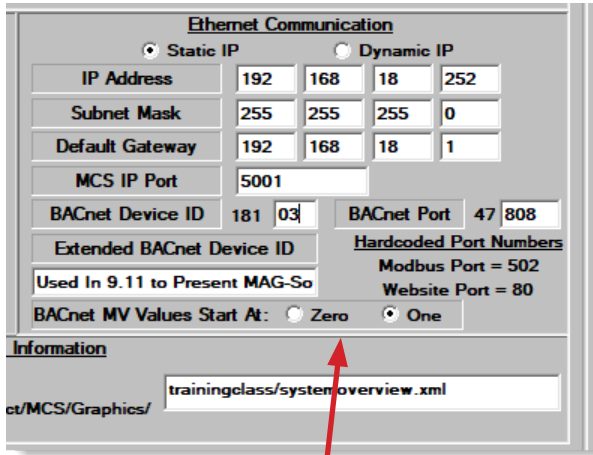

Set the MCS MAGNUM to address as shown on label:



NOTE: This BACnet Device ID will change depending on the address that will be set on the 'A' DIP Switches.

The MCS-MAGNUM BACnet DEVICE ID can be verified and changed (with the proper authorization code) from MCS-Magnum's keypad the keypad/LCD of a live unit.

1. To get authorized on Magnum do the following:
2. Press 'Menu'
3. Using ↑, ↓, →, or ← position curser to 'Passwords'
4. Press ← key.
5. Enter 4 digit password & press ←.
6. Press 'Menu' to make next selection.

The following steps will display the BACnet Device ID:



(to change the address you first must be authorized)

1. \Press the MENU key and then Using ↑, ↓, →, or ← position curser to Serv Tools then press the ENTER key.
2. then Using ↑, ↓, →, or ← position curser to BACnet Setting then press Enter.
3. Use ↑, ↓, curser to change the BACnet Device ID.
4. Set your desired address then press Enter.
5. Reset or cycle power to the magnum for the change to take effect.

The MCS-MAGNUM IP must be set to the address specified on the MCS-BMS-GATEWAY-NL's label (Example - 192.168.18.101). Range of default settings: 101-150



**SET MCS-MAGNUM TO:
IP ADDRESS: 192.168.18.101
SUBNET MASK: 255.255.255.0
DEFAULT GATEWAY: 192.168.18.1**

The MCS-MAGNUM IP address can be verified and changed (with the proper authorization code) from the MCS-Magnum's Keypad/LCD of a live unit.

The following steps will display the IP Address settings:
(to change the address you first must be authorized)

1. Press the MENU key and then Using **↑**, **↓**, **→**, or **←** position cursor to Serv Tools then press the ENTER key.
2. Then Using **↑**, **↓**, **→** or **←** position cursor to Serv Tools then press Enter.
3. Then Using **↑**, **↓**, **→**, or **←** position cursor to Ethernet Network then press Enter.
4. Then Using **↑**, **↓**, **→**, or **←** position cursor to IP address then press Enter.
5. Using **↑**, **↓** to increase and decrease the first set of values then use the **→** to select the next set of numbers and use **↑**, **↓** to increase and decrease the second value and repeat the previous steps for rest of the ip address.
6. Once you have set the desired address press the Enter key.
7. Reset or cycle power to the magnum for the change to take effect.

The MCS-MAGNUM IP address can be verified and changed (with the proper authorization code) from MCS-CONNECT of a live unit.

The following steps will display the IP Address settings:
(to change the address you first must be authorized)

1. Connect to your MCS-Controller thru MCS-CONNECT
2. Click on the 'SERVICE' tab
3. Click on the 'ETHERNET' tab
4. Make changes to the IP address and any other changes as shown on the MCS-BMS-GATEWAY-NL label.
5. Save your changes

4.5. Biasing the RS-485 Device Network

- An RS-485 network with more than one device needs to have biasing to ensure proper communication. The biasing only needs to be done on one device.
- The MCS-BMS-GATEWAY-NL has 510 Ohm resistors that can be used to set the biasing.
- The MCS-BMS-GATEWAY-NL's default positions from the factory for the Biasing jumpers are OFF.
- The OFF position is when the 2 RED biasing jumpers straddle the 4 pins closest to the outside of the board of the MCS-BMS-GATEWAY-NL. (Figure 9)
- Only turn biasing ON:
- IF the BMS cannot see more than one device connected to the MCS-BMS-GATEWAY-NL AND all the settings (wiring, and DIP switches) have been checked.
- To turn biasing ON, move the 2 RED biasing jumpers to straddle the 4 pins closest to the inside of the board of the MCS-BMS-GATEWAY-NL.

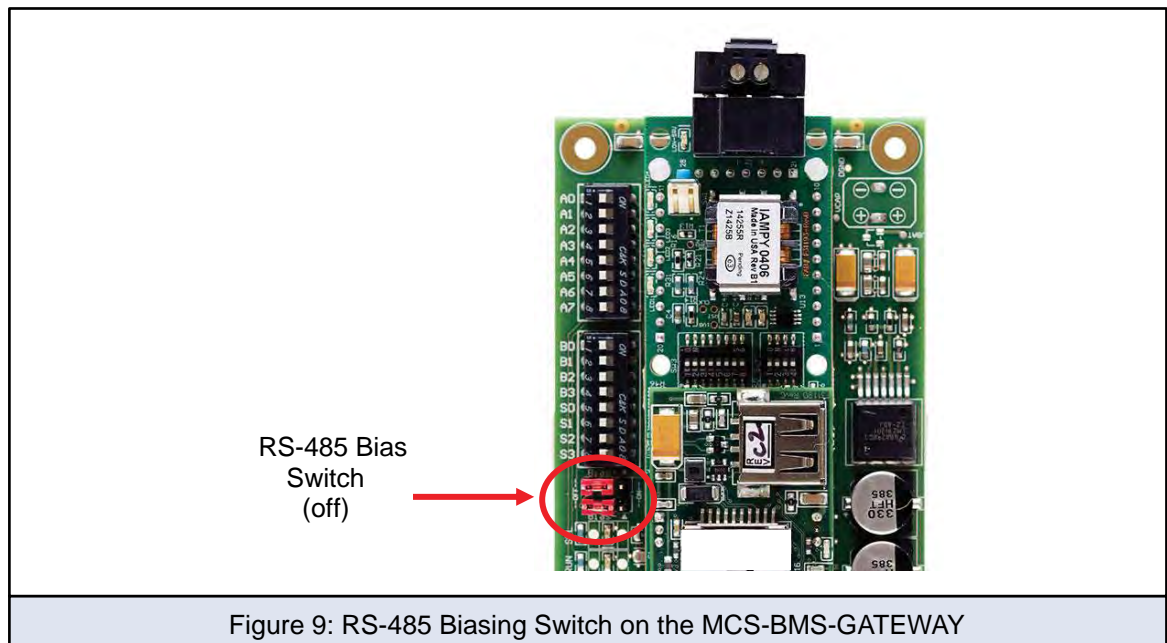

4.6. End of Line Termination Switch for the Modbus RS-485 Device Network

- On long RS-485 cabling runs, the RS-485 trunk must be properly terminated at each end.
- The MCS-BMS-GATEWAY-NL has an End of Line (EOL) blue jumper. The default setting for this Blue EOL switch is OFF with the jumper straddling the pins closest to the inside of the board of the MCS-BMS-GATEWAY-NL.
- On short cabling runs the EOL switch does not need to be turned ON
- If the MCS-BMS-GATEWAY-NL is placed at one of the ends of the trunk, set the blue EOL jumper to the ON position straddling the pins closest to the outside of the board of the MCS-BMS-GATEWAY-NL.
- Always leave the single Red Jumper in the A position (default factory setting).

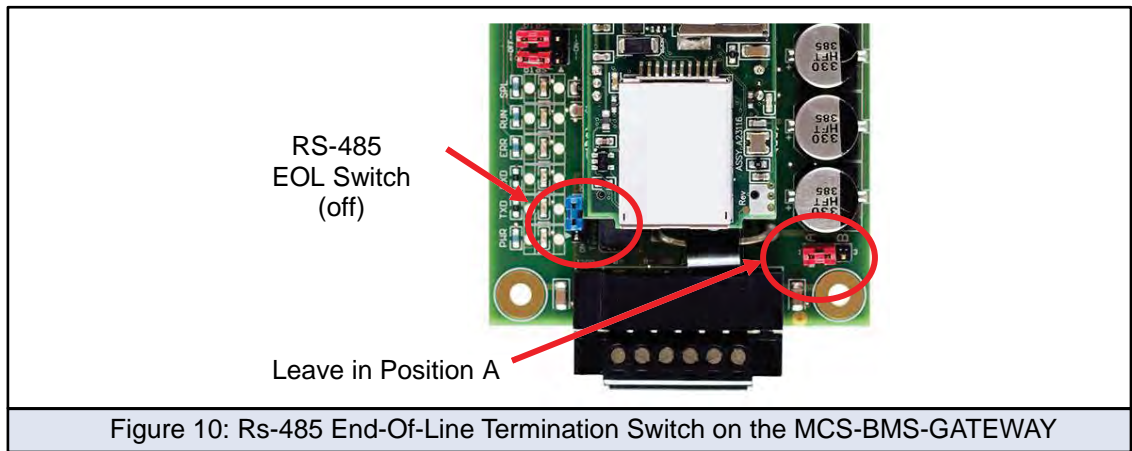

Figure 10: Rs-485 End-Of-Line Termination Switch on the MCS-BMS-GATEWAY

4.7. Power-Up MCS-BMS-GATEWAY-NL

Apply power to MCS-BMS-GATEWAY-NL as show below in Figure 13. Ensure that the power supply used complies with the specifications provided in chapter 9.

1. MCS-BMS-GATEWAY-NL accepts either 9-30VDC or 12-24 VAC on pins 4 and 5.
2. Frame GND should be connected.

Power Requirement for MCS-BMS-GATEWAY-NL External Gateway			
	Current Draw Type		
MCS-BMS-GATEWAY-NL Family	12VDC/VAC	24VDC/VAC	30VDC
FPC – ED4 (Typical)	210mA	130mA	90mA
FPC – ED4 (Maximum)	250mA	170mA	110mA
NOTE: These values are 'nominal' and a safety margin should be added to the power supply of the host system. A safety margin of 25% is recommended.			
Figure 12: Required current draw for the MCS-BMS-GATEWAY-NL			

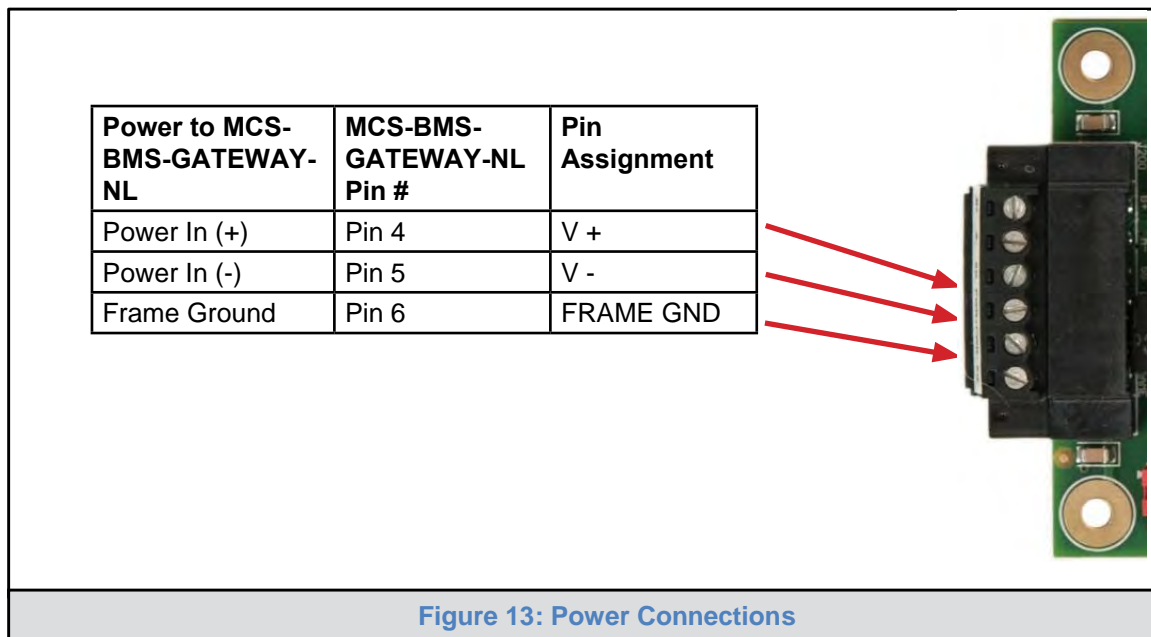

Chapter - 5. Programming a MCS-BMS GATEWAY-NL

- Ensure that FieldServer Toolbox is loaded onto the local PC. Otherwise, download the FieldServer-Toolbox.zip via the MCS WEBSITE Software Downloads.
- Extract the executable file and complete the installation.

1. Connect a standard Cat-5 Ethernet cable between the user's PC and MCS-BMS-GATEWAY-NL.
2. Double click on the FS Toolbox Utility and click Discover Now on the splash page.
3. Check for the IP Address of the desired gateway.

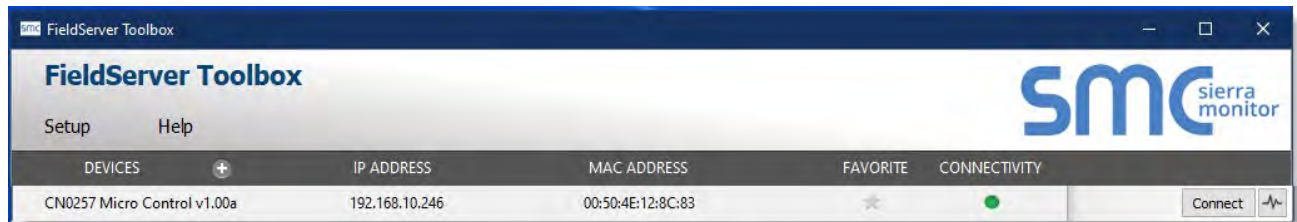

4. NOTE: If the connect button is greyed out and the CONNECTIVITY light is yellow, the MCS-BMS-GATEWAY-NL IP Address must be set to be on the same network as the PC.

5.1. Connecting A PC to the MCS-BMS-GATEWAY-NL

1. Check that the IP network adapter settings of the PC matches the MCS-BMS-GATEWAY-NL. The Default IP Address of the MCS-BMS-GATEWAY-NL is 192.168.18.201, Subnet Mask is 255.255.255.0, Default Gateway is 192.168.18.1. Ensure that the IP address is 192.168.18.xxx, the Subnet mask is 255.255.255.0 and the Default Gateway is 192.168.18.1
2. Gateway is 192.168.18.1
3. Ensure that the PC and MCS-BMS-GATEWAY-NL are on the same IP Network, or assign a Static IP Address to the PC on the 192.168.18.XXX network
4. Ensure that all other network adapters active on the PC, especially wireless adapters are disabled

5.2. Connect the PC to MCS-BMS-GATEWAY-NL via the Ethernet Port

5.2.1 For Windows 7 or later

1. Find the search field in the local computer's taskbar (usually to the right of the windows icon and type in "Control Panel".
2. Click "Control Panel", click "Network and Internet"
3. Right-click on Local Area Connection > Properties



4. Click the Okay button to close the Internet Protocol window and the Close button to close the Ethernet Properties window.

6.1. How to Create CSV Files:

1. Open MCS-Config program and load the config you are working on.
2. Click on Setup.

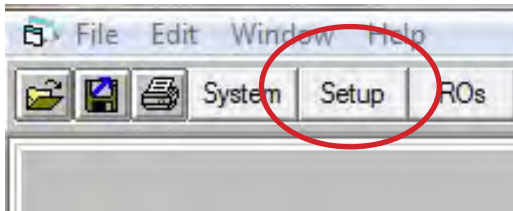

3. Be sure to set IP Address, Subnet Mask, Default Gateway, MCS IP Port and BACnet Device ID, then save config file. **DO NOT CHANGE BACnet DEVICE ID ONCE CSV FILES ARE CREATED!!**

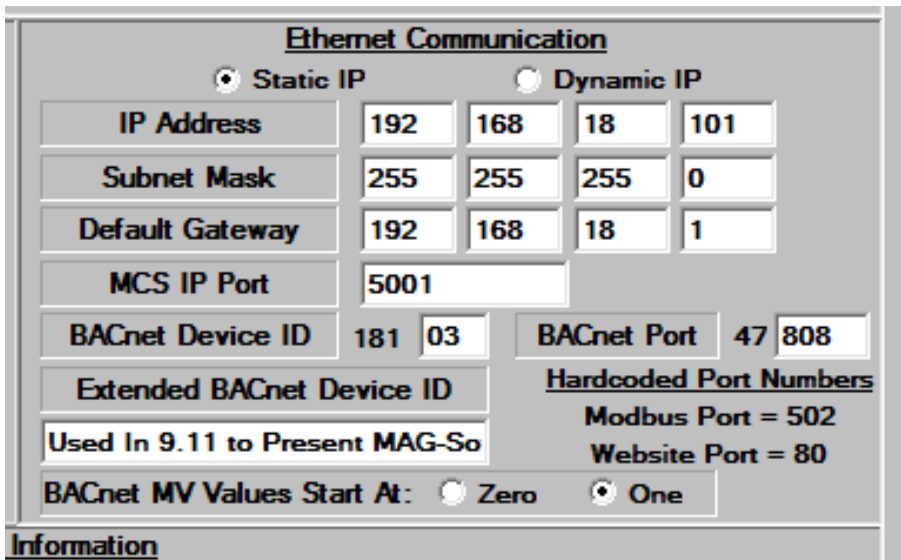

4. Click on BMS POINTS.

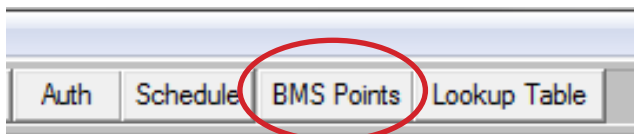

5. Click on Create MCS-BMS-GATEWAY-NL CSV Files.

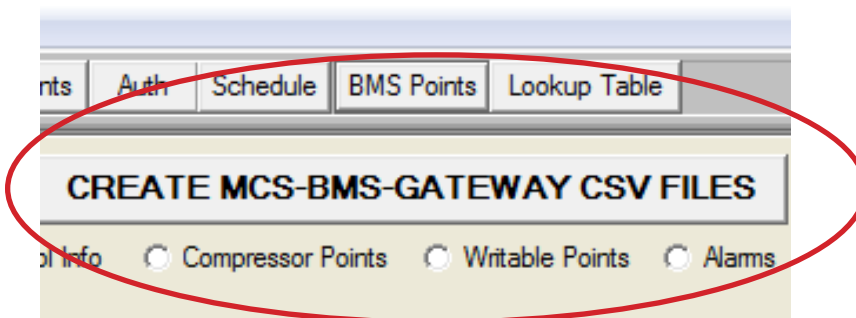

6. When popup window comes up click ok.

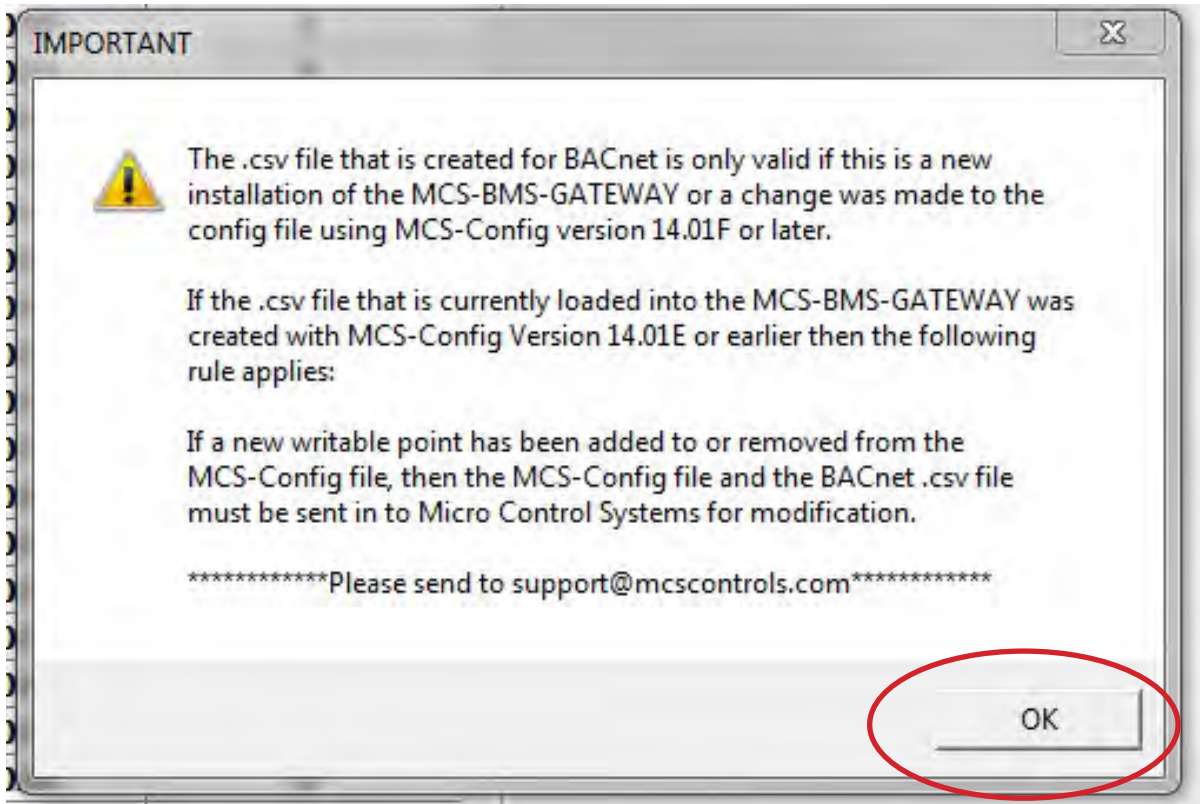

7. When prompted, select the file location where you want to save the csv files. This would be the time to name the CSV files, there is a 15 character maximum not including the file extension. If you do not name the file it will default to the first 15 characters of the config name. Then click save

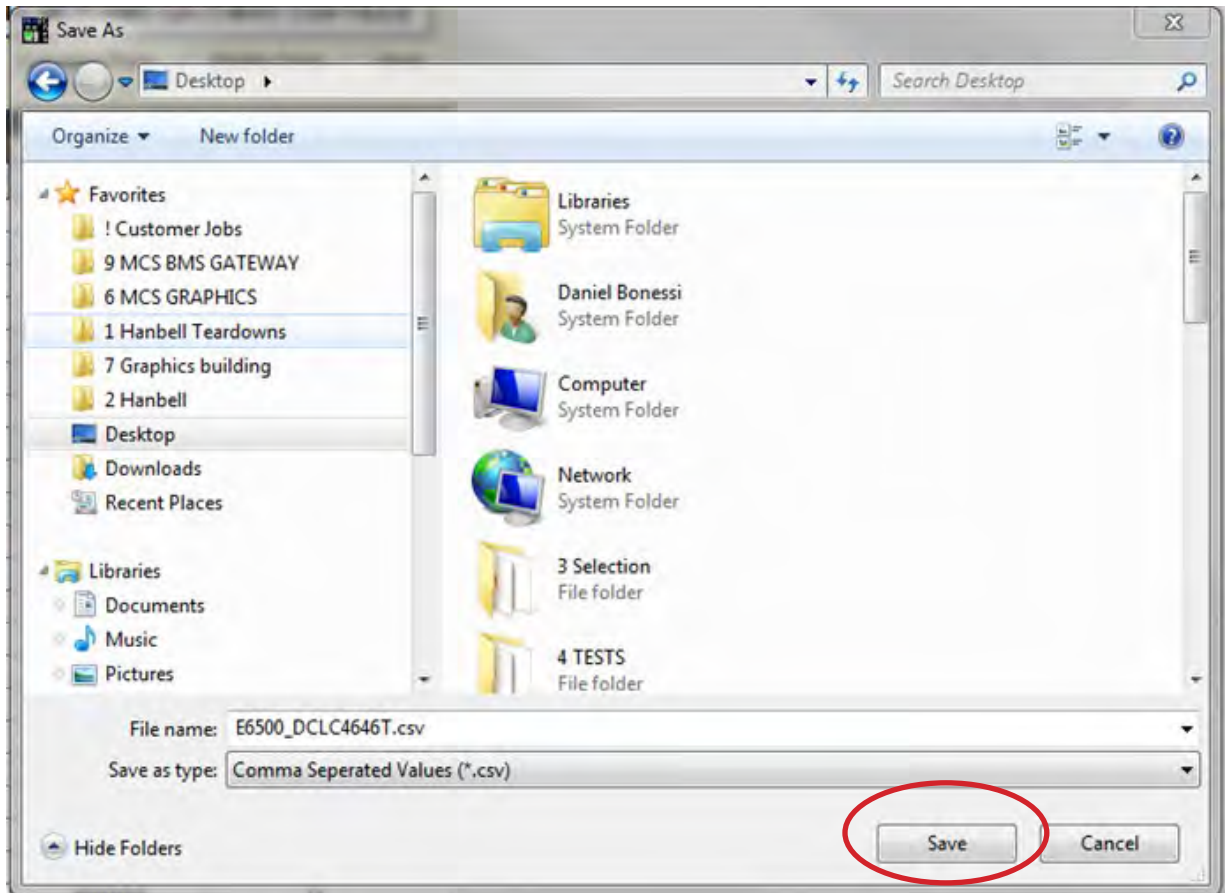

MCS-Config will create FIVE CSV file:

- Config.csv
- bac.csv = BACnet
- Jn2.csv = Johnson N2
- mod.csv = Modbus

6.2. How to Program the MCS-BMS-GATEWAY-NL with the CSV Files:

What's Needed:

- A. Field Server Toolbox program installed on a computer.**
 - B. An Ethernet Cable. (crossover cable is only required when connected from gateway to magnum)**
 - C. CSV files created from the MCS-MAGNUM Controller CFG.**
1. Connect PC to a powered BMS-GATEWAY with an Ethernet Cable.
 2. Open Field Server Toolbox Program. (If running program for the first time click on **'DISCOVER NOW', unclick when closing program**). The MCS-BMS-GATEWAY you're connected to will show up on the top line giving you the IP address and MAC address. Also you may need to right click and run as Administrator if the Gateway did not show up.
 3. Look at **CONNECTIVITY column lights**,
 - a. If Blue, it is a NEW CONNECTION**
 - b. If GREEN, click Connect**
 - c. If YELLOW, it is not on same network so go do 3a**
 4. Click **Diagnostics and Debugging**.
 5. Click **Setup**.
 6. Click **File Transfer**.
 7. Click the **Configuration tab**, then click **Choose Files**.
 8. In **Pop Up file browser**, navigate to the saved CSV files, select **Config** and click open .
 9. Click **Submit**.
 10. Click the **General Tab**, then **click Choose Files**
 11. Select the correct BMS protocol file, than click open.
 - a. bac for BacNet MS/TP
 - b. jn2 for Johnson N2
 - c. lon for Lontalk (not available on MCS-BMS-GATEWAY-NL)
 - d. mod for Modbus over IP
 12. Click **Submit**.
 13. Click **System Restart** to reboot the BMS GATEWAY card and refresh the web browser.
 14. Close the web browser and the Field Server Toolbox.
 15. Reconnect the BMS GATEWAY card to the MCS MAGNUM and have the building management system discover the card.

Note 3a

You need to setup your PC to the same network as the BMS Gateway.

1. Type in **'ncpa.cpl'** in the task bar search field.
2. Right click on **Local Area Connection** and left click on **Properties**.
3. Double left click on **Internet Protocol Version 4 (TCP/IP v4)**.
4. Select **'Use the following IP address'** and enter a static IP address on the same subnet. With the last number being different than the Gateway(192.168.18.xx)
5. Click **OK**.
6. Open **Field Server Toolbox** and click on **Discover Now**. The **Connect** button should be accessible.

Chapter - 7. APPENDIX

7.1. BMS Address DIP Switch Settings

A7	A6	A5	A4	A3	A2	A1	A0	Address
Off	Off	Off	Off	Off	Off	Off	On	1
Off	Off	Off	Off	Off	Off	On	Off	2
Off	Off	Off	Off	Off	Off	On	On	3
Off	Off	Off	Off	Off	On	Off	Off	4
Off	Off	Off	Off	Off	On	Off	On	5
Off	Off	Off	Off	Off	On	On	Off	6
Off	Off	Off	Off	Off	On	On	On	7
Off	Off	Off	Off	On	Off	Off	Off	8
Off	Off	Off	Off	On	Off	Off	On	9
Off	Off	Off	Off	On	Off	On	Off	10
Off	Off	Off	Off	On	Off	On	On	11
Off	Off	Off	Off	On	On	Off	Off	12
Off	Off	Off	Off	On	On	Off	On	13
Off	Off	Off	Off	On	On	On	Off	14
Off	Off	Off	Off	On	On	On	On	15
Off	Off	Off	On	Off	Off	Off	Off	16
Off	Off	Off	On	Off	Off	Off	On	17
Off	Off	Off	On	Off	Off	On	Off	18
Off	Off	Off	On	Off	Off	On	On	19
Off	Off	Off	On	Off	On	Off	Off	20
Off	Off	Off	On	Off	On	Off	On	21
Off	Off	Off	On	Off	On	On	Off	22
Off	Off	Off	On	Off	On	On	On	23
Off	Off	Off	On	On	Off	Off	Off	24
Off	Off	Off	On	On	Off	Off	On	25
Off	Off	Off	On	On	Off	On	Off	26
Off	Off	Off	On	On	Off	On	On	27
Off	Off	Off	On	On	On	Off	Off	28
Off	Off	Off	On	On	On	Off	On	29
Off	Off	Off	On	On	On	On	Off	30
Off	Off	Off	On	On	On	On	On	31
Off	Off	On	Off	Off	Off	Off	Off	32
Off	Off	On	Off	Off	Off	Off	On	33
Off	Off	On	Off	Off	Off	On	Off	34
Off	Off	On	Off	Off	Off	On	On	35
Off	Off	On	Off	Off	On	Off	Off	36
Off	Off	On	Off	Off	On	Off	On	37
Off	Off	On	Off	Off	On	On	Off	38
Off	Off	On	Off	Off	On	On	On	39
Off	Off	On	Off	On	Off	Off	Off	40

Off	Off	On	Off	On	Off	Off	On	41
Off	Off	On	Off	On	Off	On	Off	42
Off	Off	On	Off	On	Off	On	On	43
Off	Off	On	Off	On	On	Off	Off	44
Off	Off	On	Off	On	On	Off	On	45
Off	Off	On	Off	On	On	On	Off	46
Off	Off	On	Off	On	On	On	On	47
Off	Off	On	On	Off	Off	Off	Off	48
Off	Off	On	On	Off	Off	Off	On	49
Off	Off	On	On	Off	Off	On	Off	50
Off	Off	On	On	Off	Off	On	On	51
Off	Off	On	On	Off	On	Off	Off	52
Off	Off	On	On	Off	On	Off	On	53
Off	Off	On	On	Off	On	On	Off	54
Off	Off	On	On	Off	On	On	On	55
Off	Off	On	On	On	Off	Off	Off	56
Off	Off	On	On	On	Off	Off	On	57
Off	Off	On	On	On	Off	On	Off	58
Off	Off	On	On	On	Off	On	On	59
Off	Off	On	On	On	On	Off	Off	60
Off	Off	On	On	On	On	Off	On	61
Off	Off	On	On	On	On	On	Off	62
Off	Off	On	On	On	On	On	On	63
Off	On	Off	Off	Off	Off	Off	Off	64
Off	On	Off	Off	Off	Off	Off	On	65
Off	On	Off	Off	Off	Off	On	Off	66
Off	On	Off	Off	Off	Off	On	On	67
Off	On	Off	Off	Off	On	Off	Off	68
Off	On	Off	Off	Off	On	Off	On	69
Off	On	Off	Off	Off	On	On	Off	70
Off	On	Off	Off	Off	On	On	On	71
Off	On	Off	Off	On	Off	Off	Off	72
Off	On	Off	Off	On	Off	Off	On	73
Off	On	Off	Off	On	Off	On	Off	74
Off	On	Off	Off	On	Off	On	On	75
Off	On	Off	Off	On	On	Off	Off	76
Off	On	Off	Off	On	On	Off	On	77
Off	On	Off	Off	On	On	On	Off	78
Off	On	Off	Off	On	On	On	On	79
Off	On	Off	On	Off	Off	Off	Off	80
Off	On	Off	On	Off	Off	Off	On	81
Off	On	Off	On	Off	Off	On	Off	82
Off	On	Off	On	Off	Off	On	On	83
Off	On	Off	On	Off	On	Off	Off	84

A7	A6	A5	A4	A3	A2	A1	A0	Address
Off	On	Off	On	Off	On	On	Off	86
Off	On	Off	On	Off	On	On	On	87
Off	On	Off	On	On	Off	Off	Off	88
Off	On	Off	On	On	Off	Off	On	89
Off	On	Off	On	On	Off	On	Off	90
Off	On	Off	On	On	Off	On	On	91
Off	On	Off	On	On	On	Off	Off	92
Off	On	Off	On	On	On	Off	On	93
Off	On	Off	On	On	On	On	Off	94
Off	On	Off	On	On	On	On	On	95
Off	On	On	Off	Off	Off	Off	Off	96
Off	On	On	Off	Off	Off	Off	On	97
Off	On	On	Off	Off	Off	On	Off	98
Off	On	On	Off	Off	Off	On	On	99
Off	On	On	Off	Off	On	Off	Off	100
Off	On	On	Off	Off	On	Off	On	101
Off	On	On	Off	Off	On	On	Off	102
Off	On	On	Off	Off	On	On	On	103
Off	On	On	Off	On	Off	Off	Off	104
Off	On	On	Off	On	Off	Off	On	105
Off	On	On	Off	On	Off	On	Off	106
Off	On	On	Off	On	Off	On	On	107
Off	On	On	Off	On	On	Off	Off	108
Off	On	On	Off	On	On	Off	On	109
Off	On	On	Off	On	On	On	Off	110
Off	On	On	Off	On	On	On	On	111
Off	On	On	On	Off	Off	Off	Off	112
Off	On	On	On	Off	Off	Off	On	113
Off	On	On	On	Off	Off	On	Off	114
Off	On	On	On	Off	Off	On	On	115
Off	On	On	On	Off	On	Off	Off	116
Off	On	On	On	Off	On	Off	On	117
Off	On	On	On	Off	On	On	Off	118
Off	On	On	On	Off	On	On	On	119
Off	On	On	On	On	Off	Off	Off	120
Off	On	On	On	On	Off	Off	On	121
Off	On	On	On	On	Off	On	Off	122
Off	On	On	On	On	Off	On	On	123
Off	On	On	On	On	On	Off	Off	124
Off	On	On	On	On	On	Off	On	125
Off	On	On	On	On	On	On	Off	126
Off	On	On	On	On	On	On	On	127
On	Off	Off	Off	Off	Off	Off	Off	128

A7	A6	A5	A4	A3	A2	A1	A0	Address
On	Off	Off	Off	Off	Off	Off	On	129
On	Off	Off	Off	Off	Off	On	Off	130
On	Off	Off	Off	Off	Off	On	On	131
On	Off	Off	Off	Off	On	Off	Off	132
On	Off	Off	Off	Off	On	Off	On	133
On	Off	Off	Off	Off	On	On	Off	134
On	Off	Off	Off	Off	On	On	On	135
On	Off	Off	Off	On	Off	Off	Off	136
On	Off	Off	Off	On	Off	Off	On	137
On	Off	Off	Off	On	Off	On	Off	138
On	Off	Off	Off	On	Off	On	On	139
On	Off	Off	Off	On	On	Off	Off	140
On	Off	Off	Off	On	On	Off	On	141
On	Off	Off	Off	On	On	On	Off	142
On	Off	Off	Off	On	On	On	On	143
On	Off	Off	On	Off	Off	Off	Off	144
On	Off	Off	On	Off	Off	Off	On	145
On	Off	Off	On	Off	Off	On	Off	146
On	Off	Off	On	Off	Off	On	On	147
On	Off	Off	On	Off	On	Off	Off	148
On	Off	Off	On	Off	On	Off	On	149
On	Off	Off	On	Off	On	On	Off	150
On	Off	Off	On	Off	On	On	On	151
On	Off	Off	On	On	Off	Off	Off	152
On	Off	Off	On	On	Off	Off	On	153
On	Off	Off	On	On	Off	On	Off	154
On	Off	Off	On	On	Off	On	On	155
On	Off	Off	On	On	On	Off	Off	156
On	Off	Off	On	On	On	Off	On	157
On	Off	Off	On	On	On	On	Off	158
On	Off	Off	On	On	On	On	On	159
On	Off	On	Off	Off	Off	Off	Off	160
On	Off	On	Off	Off	Off	Off	On	161
On	Off	On	Off	Off	Off	On	Off	162
On	Off	On	Off	Off	Off	On	On	163
On	Off	On	Off	Off	On	Off	Off	164
On	Off	On	Off	Off	On	Off	On	165
On	Off	On	Off	Off	On	On	Off	166
On	Off	On	Off	Off	On	On	On	167
On	Off	On	Off	On	Off	Off	Off	168
On	Off	On	Off	On	Off	Off	On	169
On	Off	On	Off	On	Off	On	Off	170
On	Off	On	Off	On	Off	On	On	171

A7	A6	A5	A4	A3	A2	A1	A0	Address
On	Off	On	Off	On	On	Off	Off	172
On	Off	On	Off	On	On	Off	On	173
On	Off	On	Off	On	On	On	Off	174
On	Off	On	Off	On	On	On	On	175
On	Off	On	On	Off	Off	Off	Off	176
On	Off	On	On	Off	Off	Off	On	177
On	Off	On	On	Off	Off	On	Off	178
On	Off	On	On	Off	Off	On	On	179
On	Off	On	On	Off	On	Off	Off	180
On	Off	On	On	Off	On	Off	On	181
On	Off	On	On	Off	On	On	Off	182
On	Off	On	On	Off	On	On	On	183
On	Off	On	On	On	Off	Off	Off	184
On	Off	On	On	On	Off	Off	On	185
On	Off	On	On	On	Off	On	Off	186
On	Off	On	On	On	Off	On	On	187
On	Off	On	On	On	On	Off	Off	188
On	Off	On	On	On	On	Off	On	189
On	Off	On	On	On	On	On	Off	190
On	Off	On	On	On	On	On	On	191
On	On	Off	Off	Off	Off	Off	Off	192
On	On	Off	Off	Off	Off	Off	On	193
On	On	Off	Off	Off	Off	On	Off	194
On	On	Off	Off	Off	Off	On	On	195
On	On	Off	Off	Off	On	Off	Off	196
On	On	Off	Off	Off	On	Off	On	197
On	On	Off	Off	Off	On	On	Off	198
On	On	Off	Off	Off	On	On	On	199
On	On	Off	Off	On	Off	Off	Off	200
On	On	Off	Off	On	Off	Off	On	201
On	On	Off	Off	On	Off	On	Off	202
On	On	Off	Off	On	Off	On	On	203
On	On	Off	Off	On	On	Off	Off	204
On	On	Off	Off	On	On	Off	On	205
On	On	Off	Off	On	On	On	Off	206
On	On	Off	Off	On	On	On	On	207
On	On	Off	On	Off	Off	Off	Off	208
On	On	Off	On	Off	Off	Off	On	209
On	On	Off	On	Off	Off	On	Off	210
On	On	Off	On	Off	Off	On	On	211
On	On	Off	On	Off	On	Off	Off	212
On	On	Off	On	Off	On	Off	On	213
On	On	Off	On	Off	On	On	Off	214

A7	A6	A5	A4	A3	A2	A1	A0	Address
On	On	Off	On	Off	On	On	On	215
On	On	Off	On	On	Off	Off	Off	216
On	On	Off	On	On	Off	Off	On	217
On	On	Off	On	On	Off	On	Off	218
On	On	Off	On	On	Off	On	On	219
On	On	Off	On	On	On	Off	Off	220
On	On	Off	On	On	On	Off	On	221
On	On	Off	On	On	On	On	Off	222
On	On	Off	On	On	On	On	On	223
On	On	On	Off	Off	Off	Off	Off	224
On	On	On	Off	Off	Off	Off	On	225
On	On	On	Off	Off	Off	On	Off	226
On	On	On	Off	Off	Off	On	On	227
On	On	On	Off	Off	On	Off	Off	228
On	On	On	Off	Off	On	Off	On	229
On	On	On	Off	Off	On	On	Off	230
On	On	On	Off	Off	On	On	On	231
On	On	On	Off	On	Off	Off	Off	232
On	On	On	Off	On	Off	Off	On	233
On	On	On	Off	On	Off	On	Off	234
On	On	On	Off	On	Off	On	On	235
On	On	On	Off	On	On	Off	Off	236
On	On	On	Off	On	On	Off	On	237
On	On	On	Off	On	On	On	Off	238
On	On	On	Off	On	On	On	On	239
On	On	On	On	Off	Off	Off	Off	240
On	On	On	On	Off	Off	Off	On	241
On	On	On	On	Off	Off	On	Off	242
On	On	On	On	Off	Off	On	On	243
On	On	On	On	Off	On	Off	Off	244
On	On	On	On	Off	On	Off	On	245
On	On	On	On	Off	On	On	Off	246
On	On	On	On	Off	On	On	On	247
On	On	On	On	On	Off	Off	Off	248
On	On	On	On	On	Off	Off	On	249
On	On	On	On	On	Off	On	Off	250
On	On	On	On	On	Off	On	On	251
On	On	On	On	On	On	Off	Off	252
On	On	On	On	On	On	Off	On	253
On	On	On	On	On	On	On	Off	254
On	On	On	On	On	On	On	On	255



Providing HVAC/R Control Solutions Worldwide

5580 Enterprise Pkwy. Fort Myers, FL 33905

Office: (239) 694-0089

Fax: (239) 694-0031

www.mcsccontrols.com