



# Install and Startup

## APP #143

Rev 3.7.6

# YASKAWA VFD GA800 / A1000 VARIABLE SPEED DRIVE



Any questions regarding this release, contact: [support@mcscontrols.com](mailto:support@mcscontrols.com)

Micro Control Systems, Inc. 5580 Enterprise Parkway Fort Myers, Florida 33905  
(239)694-0089 FAX: (239)694-0031 [www.mcscontrols.com](http://www.mcscontrols.com)

Information contained in this document has been prepared by Micro Control Systems, Inc. and is copyright © protected 2023.  
Copying or distributing this document is prohibited unless expressly approved by MCS.

# GA800 / A1000 Hardwired Diagram

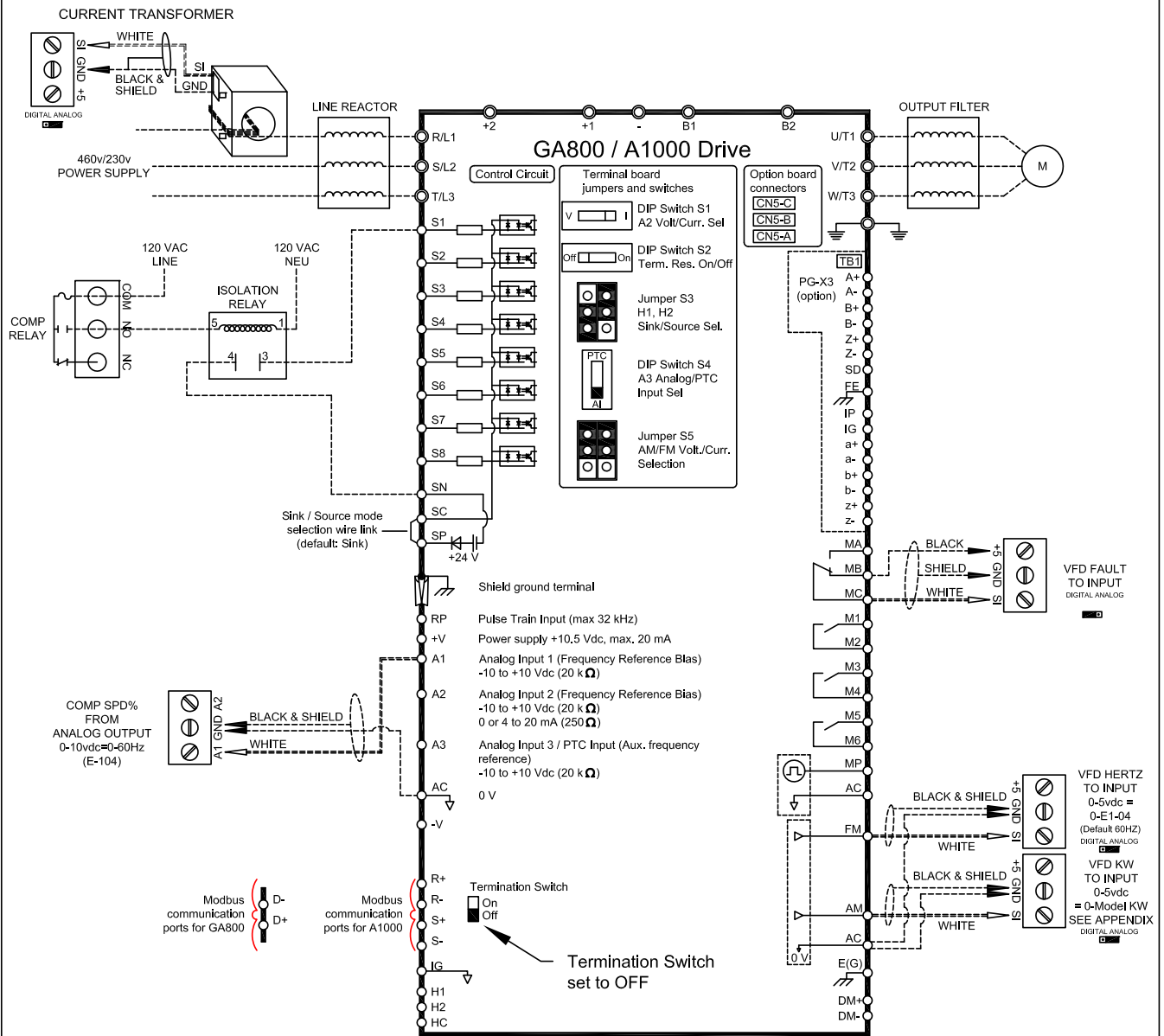

Contact closure across S1-SN will activate Drive's "RUN" command. Drive will ramp up to Lower Limit defined by D2-02 then be controlled by 0-10Vdc across A1-AC.

	Date	08/02/2022
	Revision	D
	CAD Tech	I. Mitchell

# MCS YASKAWA AC DRIVE - GA800 / A1000 SETTINGS

## HANBELL(Hardwired)VFD SETTINGS

Key features include: Start/Stop, 0-10V Speed Reference, Speed Reference Feedback				
A1000 Parameters & Values		Parameter Description		Comments
#	Value	Comments	Default values in parenthesis (xxxxxx)	YEA / Mfg / User
A1-02	0	V/f	“Control Method Select”: 0=V/f; 1=V/f w/PG; 2=(Open Loop); 3=Closed Loop	
B1-02	1		“Run Cmd Select: 0=Operator; 1=(Terminals); 2=Modbus; 3=Option	RUN=Contact Closure at S1-SN
B1-03	1		“Stop Method”: 0=(Ramp); 1=Coast; 2=DC Inj; 3=Coast w/timer	
B1-04	1	Disable Rev	“Reverse Operation”: 0=(Enabled); 1=Disabled	
B1-07	1	Accept Run	“Local/Remote Run”: 0=(Cycle Ext Run); 1=Accept Ext Run	
B1-08	1	All Menus	“Run Cmd” Accepted: 0=(Only in Operation Menu); 1=All Menus	
B1-17	1	Accept Run	“Run Cmd at PowerUp”: 0=(Cycle Ext Run); 1=Accept Run cmd	
C1-01	10		“Acceleration Time #1”: Default=10 seconds (range=0.0 - 6000.0)	
C1-02	10		“Deceleration Time #1”: Default=10 seconds (range=0.0 - 6000.0)	
C6-01	0		“Drive Duty Select”: 0=Heavy Duty HD; 1=(Normal Duty ND)	
C6-02	1		“Carrier Frequency” selection. PM motor, default ‘2’ = 5.0 kHz Heavy Duty performance, default ‘1’ = 2.0 kHz Normal Duty performance, default ‘7’ Swing PWM 1	
D2-02	35%		“Freq Ref Lower Limit”: Default=0% (range=0.0 - 110% of Parm E1-04)	35% of E1-04 value
E1-01			“Input Voltage”: Default= 230,460 (range=depends on voltage class)	User must set “Input Voltage”
E1-05			MAXIMUM VOLTAGE 220 / 440	User must set motor voltage
E2-01			“Motor Rated FLA”: Set per motor nameplate FLA	“Use MCC”
H4-02	50%		Terminal FM VDC output	Limit (50% = 5 VDC)
H4-04	108	Output KW	U1-08 -Displays the output KW on the AM output.	
L1-01	2	Inv Duty VT	“Motor Overload Protection”: 0=Disabled; 1=(General); 2=Inv Duty VT	
L2-01	2	CPU Active	“Momentary Power Loss”: 0=(Disabled); 1=L2-02; 2=Power restored CPU	
L5-01	0		“Number of Auto Restarts”: Default=0 (range=0 - 10).	
o1-03	0	Determined by A1-02	Sets the unit to display Hz for frequency reference and motor speed.	
o2-01	0	Key Function Selection	0=Disabled - The LO/RE (Local/Remote) key is disabled	

# GA800 / A1000 MODBUS-I/O Diagram

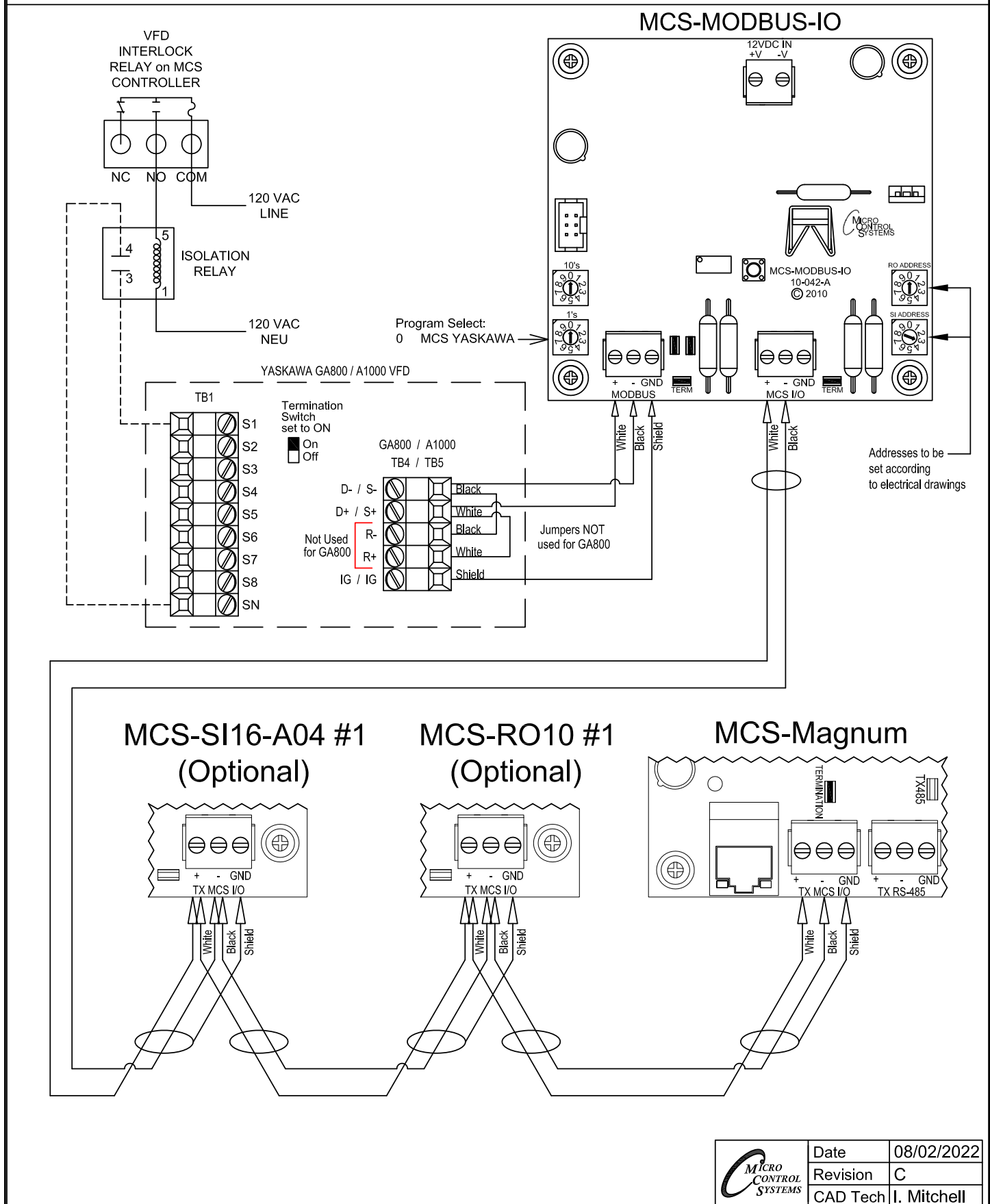

	Date	08/02/2022
	Revision	C
	CAD Tech	I. Mitchell

# MCS YASKAWA AC DRIVE - GA800 / A1000 SETTINGS

## HANBELL(MODBUS)VFD SETTINGS

Key features include: Start/Stop, 0-10V Speed Reference, Speed Reference Feedback

A1000 Parameters & Values			Parameter Description	Comments
#	Value	Comments	Default values in parenthesis (xxxxxx)	YEA / Mfg / User
A1-02	0	V/f	"Control Method Select": 0=V/f; 1=V/f w/PG; 2=(Open Loop); 3=Closed Loop	
B1-01	2	Freq Ref Sel	Sets Modbus Communication Action - 1=Hardwired; 2=Modbus; 3=Option	
B1-02	2		"Run Cmd Select: 0=Operator; 1=Hardwired; 2=Modbus; 3=Option	RUN=Contact Closure at S1-SN
B1-03	1		"Stop Method": 0=(Ramp); 1=Coast; 2=DC Inj; 3=Coast w/timer	
B1-04	1	Disable Rev	"Reverse Operation": 0=(Enabled); 1=Disabled	
B1-07	1	Accept Run	"Local/Remote Run": 0=(Cycle Ext Run); 1=Accept Ext Run	
B1-08	1	All Menus	"Run Cmd" Accepted: 0=(Only in Operation Menu); 1=All Menus	
B1-17	1	Accept Run	"Run Cmd at PowerUp": 0=(Cycle Ext Run); 1=Accept Run cmd	
C1-01	10		"Acceleration Time #1": Default=10 seconds (range=0.0 - 6000.0)	
C1-02	10		"Deceleration Time #1": Default=10 seconds (range=0.0 - 6000.0)	
C6-01	0		"Drive Duty Select": 0=Heavy Duty HD; 1=(Normal Duty ND)	
C6-02	1		"Carrier Frequency" selection. PM motor, default '2' = 5.0 kHz Heavy Duty performance, default '1' = 2.0 kHz Normal Duty performance, default '7' Swing PWM 1	
D2-02	35%		"Freq Ref Lower Limit": Default=0% (range=0.0 - 110% of Parm E1-04)	35% of E1-04 value
E1-01			"Input Voltage": Default= 230,460, 575 (range=depends on voltage class)	User must set "Input Voltage"
E1-05			MAXIMUM VOLTAGE 220 / 440	User must set motor voltage
E2-01			"Motor Rated FLA": Set per motor nameplate FLA	"Use MCC"
H1-01	25		Terminal S1 Interlock ( N.C., always detect coast to stop)	
H4-02	50%		Terminal FM VDC output	Limit (50% = 5 VDC
* H5-01	1	Drive Address	Sets the drive slave address used for communications	
H5-02	5	Comm Speed	Sets the Modbus communications speed	38400bps
H5-03	0	Parity Select	Sets the parity bit to no parity	
H5-04	1	1=Coast to Stop	Stopping Method After Communication Error	
L1-01	2	Inv Duty VT	"Motor Overload Protection": 0=Disabled; 1=(General); 2=Inv Duty VT	
L2-01	2	CPU Active	"Momentary Power Loss": 0=(Disabled); 1=L2-02; 2=Power restored CPU	
L5-01	0		"Number of Auto Restarts": Default=0 (range=0 - 10).	
o1-03	0	Determined by A1-02	Sets the unit to display Hz for frequency reference and motor speed.	
o2-01	0	Key Function Selection	0=Disabled - The LO/RE (Local/Remote) key is disabled	



\*Factory default setting - 1F - Must be changed: Arrow to H5 01 - Arrow right till '01' blinking hit enter.  
Arrow right- change '1' to '0' and change 'F' to '1'

# GA800 / A1000 Hardwired Diagram

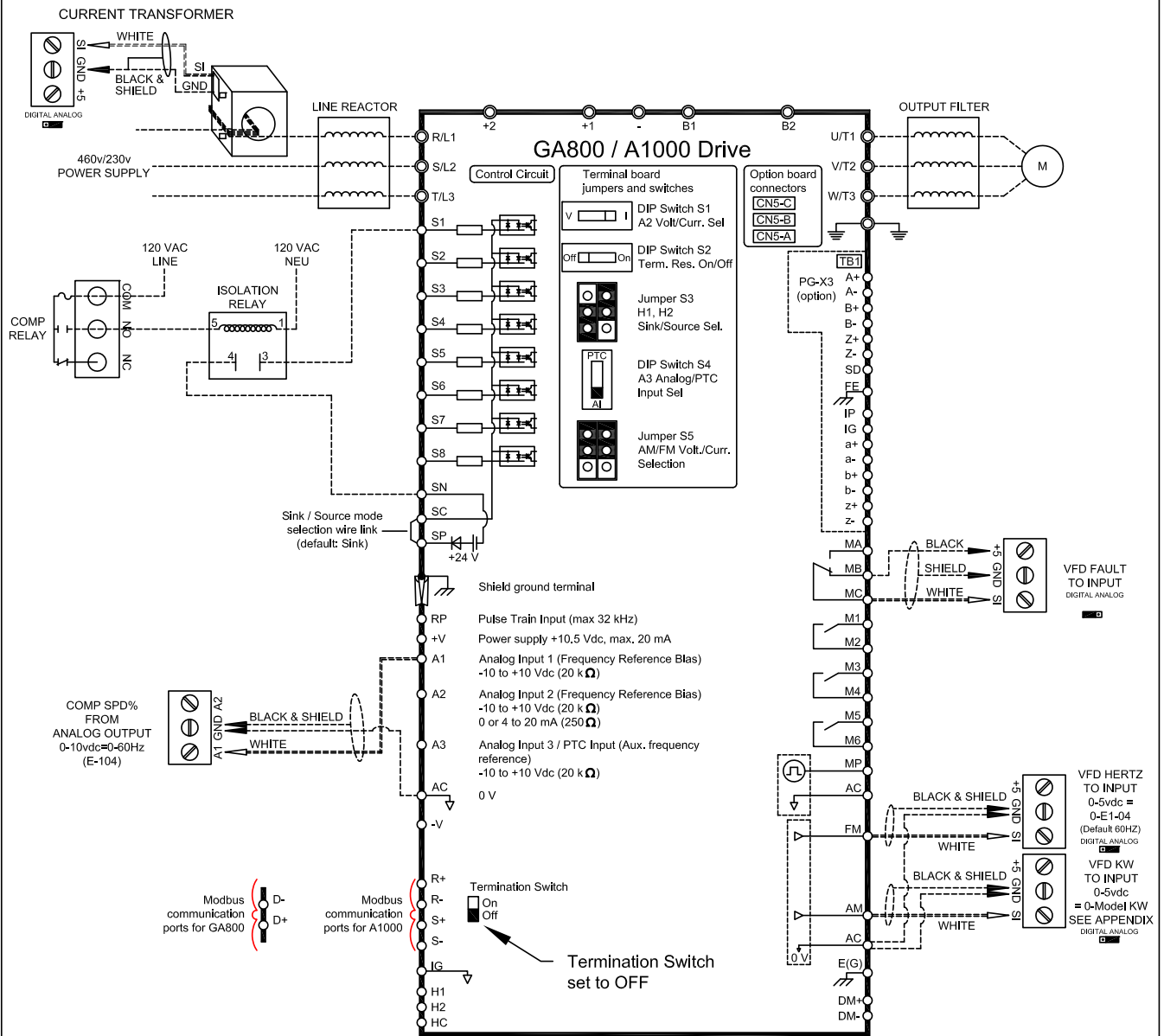

Contact closure across S1-SN will activate Drive's "RUN" command. Drive will ramp up to Lower Limit defined by D2-02 then be controlled by 0-10Vdc across A1-AC.

	Date	08/02/2022
	Revision	D
	CAD Tech	I. Mitchell

# MCS YASKAWA AC DRIVE - GA800 / A1000 SETTINGS

## CENTRIFUGAL Hardwired VFD Settings

Key features include: Start/Stop, 0-10V Speed Reference, Speed Reference Feedback				
A1000 Parameters & Values			Parameter Description	Comments
#	Value	Comments	Default values in parenthesis (xxxxxx)	YEA / Mfg / User
B1-03	1		"Stop Method": 0=(Ramp); 1=Coast; 2=DC Inj; 3=Coast w/timer	
B1-04	1	Disable Rev	"Reverse Operation": 0=(Enabled); 1=Disabled	
B1-07	1	Accept Run	"Local/Remote Run": 0=(Cycle Ext Run); 1=Accept Ext Run	
B1-08	1	All Menus	"Run Cmd" Accepted: 0=(Only in Operation Menu); 1=All Menus	
C1-01	15		"Acceleration Time #1": Default=15 seconds (range=0.0 - 6000.0)	
C1-02	90		"Deceleration Time #1": Default=90 seconds (range=0.0 - 6000.0)	
C6-02	7		"Carrier Frequency" selection. PM motor, default '2' = 5.0 kHz Heavy Duty performance, default '1' = 2.0 kHz Normal Duty performance, default '7' Swing PWM 1	
D1-01	10Hz		"Freq Ref 1	
D2-02	70%		"Freq Ref Lower Limit": Default=0% (range=0.0 - 110% of Parm E1-04)	70% of E1-04 value
E1-01			"Input Voltage": Default= 230,460 (range=depends on voltage class)	User must set "Input Voltage"
E2-01			"Motor Rated FLA": Set per motor nameplate FLA	"Note: set to Motor FLA"
H2-03	5		"Freq detection 2 closed: Output frequency is greater than or equal to the value in L\$01 with hysteresis determined by L4-02	
H4-02	50%		Terminal FM VDC output	Limit (40% = 5 VDC
H4-04	108	Output KW	U1-08 -Displays the output KW on the AM output.	
H4-05	50		Multi-Function Analog output terminal AM gain	
L5-01	0		"Number of Auto Restarts": Default=0 (range=0 - 10).	
o1-03	0	Determined by A1-02	Sets the unit to display Hz for frequency reference and motor speed.	
o2-01	0	Key Function Selection	0=Disabled - The LO/RE (Local/Remote) key is disabled	

See wiring diagram page 6

# GA800 / A1000 MODBUS-I/O Diagram

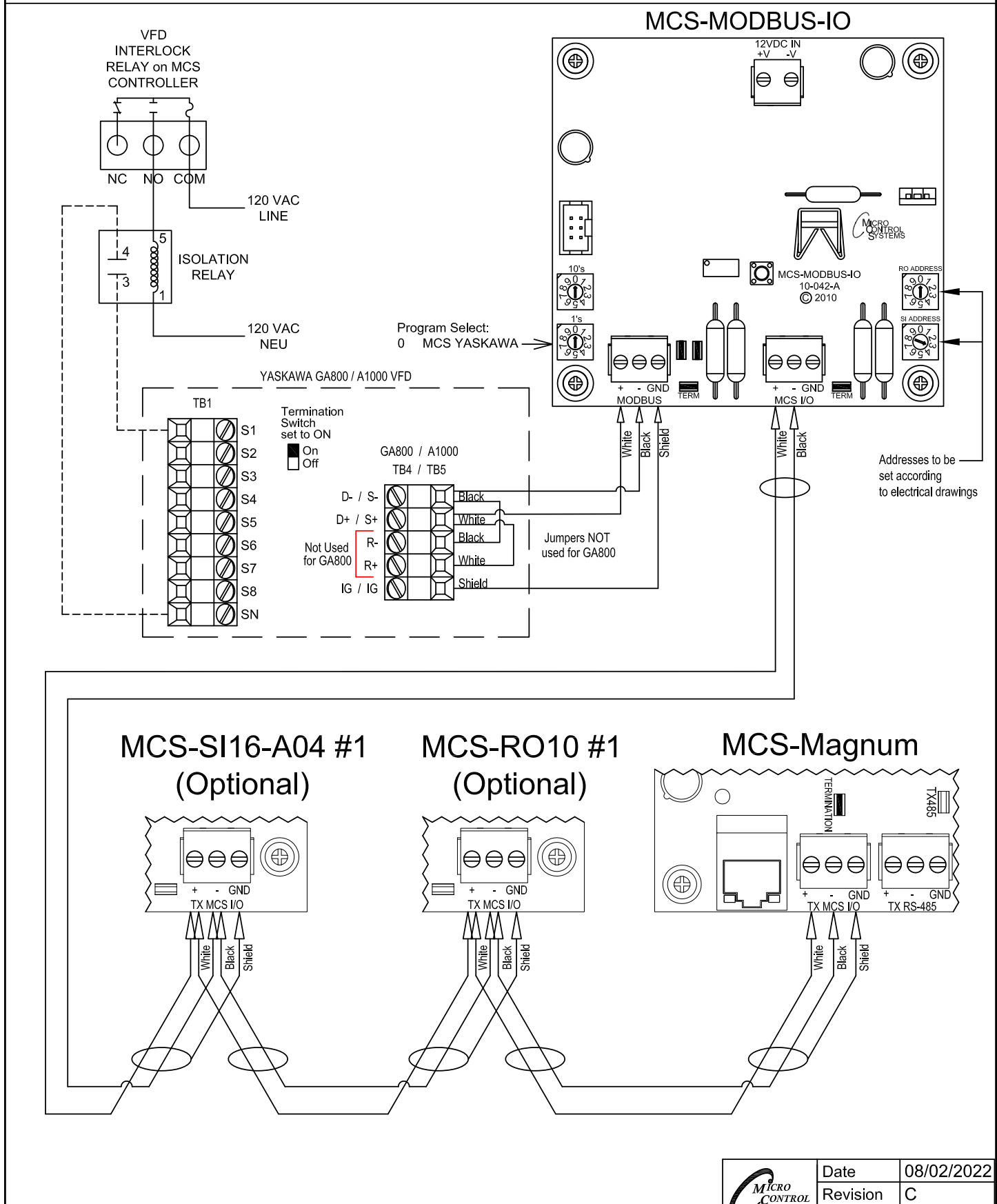

	Date	08/02/2022
	Revision	C



# MCS YASKAWA AC DRIVE - GA800 / A1000 SETTINGS

## CENTRIFUGAL MODBUS VFD Settings

Key features include: Start/Stop, 0-10V Speed Reference, Speed Reference Feedback

A1000 Parameters & Values			Parameter Description	Comments
#	Value	Comments	Default values in parenthesis (xxxxxx)	YEA / Mfg / User
B1-01	2	Freq Ref Sel	Sets Modbus Communication Action - 1=Hardwired; 2=Modbus; 3=Option	
B1-02	2		"Run Cmd Select: 0=Operator; 1=Hardwired; 2=Modbus; 3=Option	RUN=Contact Closure at S1-SN
B1-03	1		"Stop Method": 0=(Ramp); 1=Coast; 2=DC Inj; 3=Coast w/timer	
B1-04	1	Disable Rev	"Reverse Operation": 0=(Enabled); 1=Disabled	
B1-08	1	All Menus	"Run Cmd" Accepted: 0=(Only in Operation Menu); 1=All Menus	
C1-01	15		"Acceleration Time #1": Default=15 seconds (range=0.0 - 6000.0)	
C1-02	90		"Deceleration Time #1": Default=90 seconds (range=0.0 - 6000.0)	
C6-02	7		"Carrier Frequency" selection. PM motor, default '2' = 5.0 kHz Heavy Duty performance, default '1' = 2.0 kHz Normal Duty performance, default '7' Swing PWM 1	
D1-01	10Hz		"Freq Ref 1	
D2-02	70%		"Freq Ref Lower Limit": Default=0% (range=0.0 - 110% of Parm E1-04)	70% of E1-04 value
E1-01			"Input Voltage": Default= 230,460 (range=depends on voltage class)	User must set "Input Voltage"
E2-01			"Motor Rated FLA": Set per motor nameplate FLA	"Note: set to Motor FLA"
H1-01	25		Terminal S1 Interlock ( N.C., always detect coast to stop)	
H2-03	5		"Freq detection 2 closed: Output frequency is greater than or equal to the value in L\$01 with hysteresis determined by L4-02	
H4-01	108	Output power	U1-08 - Displays the output frequency. Displays units are determined by 01-03	
H4-02	50%		Terminal FM VDC output	Limit (40% = 5 VDC
H4-04	102	Output freq.	U1-02 -Display the output frequency. Displays units are determined by 01-03	
H4-05	50		Multi-Function Analog output terminal AM gain	
*	H5-01	1 Drive Address	Sets the drive slave address used for communications	
	H5-02	5 Comm Speed	Sets the Modbus communications speed	38400bps
	H5-03	0 Parity Select	Sets the parity bit to no parity	
	H5-04	2 2:=Fast-Stop	Stopping Method After Communication Error	
	L5-01	0	"Number of Auto Restarts": Default=0 (range=0 - 10).	
	o1-03	0 Determined by A1-02	Sets the unit to display Hz for frequency reference and motor speed.	
	o2-01	0 Key Function Selection	0=Disabled - The LO/RE (Local/Remote) key is disabled	

\* Factory default setting - 1F - Must be changed: Arrow to H5 01 - Arrow right till '01' blinking hit enter.  
Arrow right- change '1' to '0' and change 'F' to '1'

Wiring diagram page 8

## Revision History

Date	Author	Revision	Description
8-3-15	DEW	Rev 1.0	Install and startup
8-6-15	DEW	Rev 1.0	Edits made
2-11-16	DEW	Rev 1.1	Edits made to settings, pg 11
3-01-16	DEW	Rev 1.2	Edits made to settings, pg 11
3-7-16	DEW	Rev 1.3	Add new drawing for Hardwired
3-8-16	DEW	Rev 1.3	Add Modbus setup and wiring
3-14-16	DEW	Rev 1.4	Add Modbus, Centrifugal settings
3-28/29-16	DEW	Rev 1.4	Add new hardwire dwg
9-29-16	DEW	Rev. 1.5	Add revised Drawings
1-11-17	DEW	REv 1.6	Edits from Bret
1-12-17	DEW	REV 1.5	Drawing updates
11-02-17	DEW	REV 1.7	Add changes - b1-01- b1-02, H5-01
06-03-2019	DEW	REV 3.0	Add C602 "Carrier Frequency" selection.
08-30-19	DEW	REV 3.1	Removed bottom of pg 2 and page 3
02-25-2020	DEW	REV 3.2	ADD H-5-04 MODBUS ONLY
05-15-2020	DEW	REV 3.4	ADD E1-05 VOLTAGE MAX HANBELL HARDWIRED & MODBUS
02-17-2021	DEW	REV 3.5	UPDATE DRAWINGS
07-26-2022	DEW	REV 3.6	UPDATE PARAMETERS
08-02-2022	DEW	REV 3.6	UPDATE DRAWINGS
08-05-2022	DEW	REV 3.7.1	UPDATE DRAWINGS FOR TERMINATION
01-05-2023	DEW	REV 3.7.3	UPDATE FOR H1-01 INTERLOCK ON MODBUS SETTING
04--3-2023	DEW	REV 3.7.4	REMOVE H1-01 FROM HARDWIRED SETTING
07-12-2023	DEW	REV 3.76	ADD O2-01 LO/RE Key Function Section