

No.	Name	Note	No.	Name	Note
1	Angle valve	1/4" Flare	16	Oil connector(in)	5/8" Flare, option
2	Discharge flange	3"	17	Angle valve	1/4" Flare
3	Solenoid valve	50%(NC)	18	Refrigerant service valve	1/4" Flare
4	Solenoid valve	75%(NC)	19	Solenoid valve	Stepless(NC or NO), Option
5	Solenoid valve	25%(NC)	20	Liquid injection connector	5/8" Flare, Option
6	Liquid(oil or refrigerant) injection connector	3/8" Flare, Option	21	Suction flange	4"
7	Capillary		22	Cable box	Standard
8	Check valve	3"	23	Service flange	
9	Oil flow sight glass		24	Oil drain valve	Option
10	Oil level sight glass		25	Oil level switch	Option
11	Oil heater	150W/300W	26	Discharge temp. sensor	110°C
12	Oil filter cartridge		27	Safety Valve	1" NPT, Option
13	Oil pressure differential switch	Option	28	Economizer port	1 1/8", Solder
14	Oil connector(out)	5/8" Flare, Option	29	Over flow port	Option
15	Stop pin	Option			

\*All stop valves are optional.

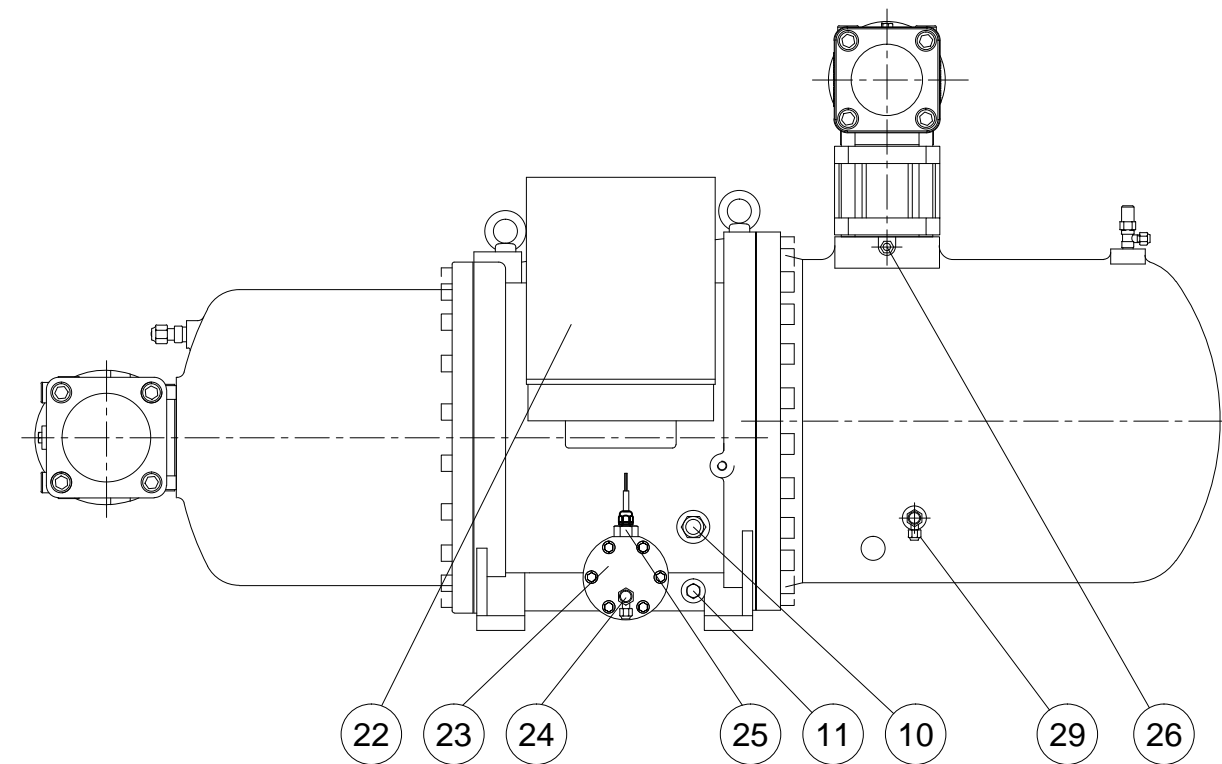

Dimensional Outline Drawing & Component Description for Stepless or Modulating-Type Capacity Control Application	
Hanbell Model	RC2-550A
Date	06/19/2024
Drawn By	ILM

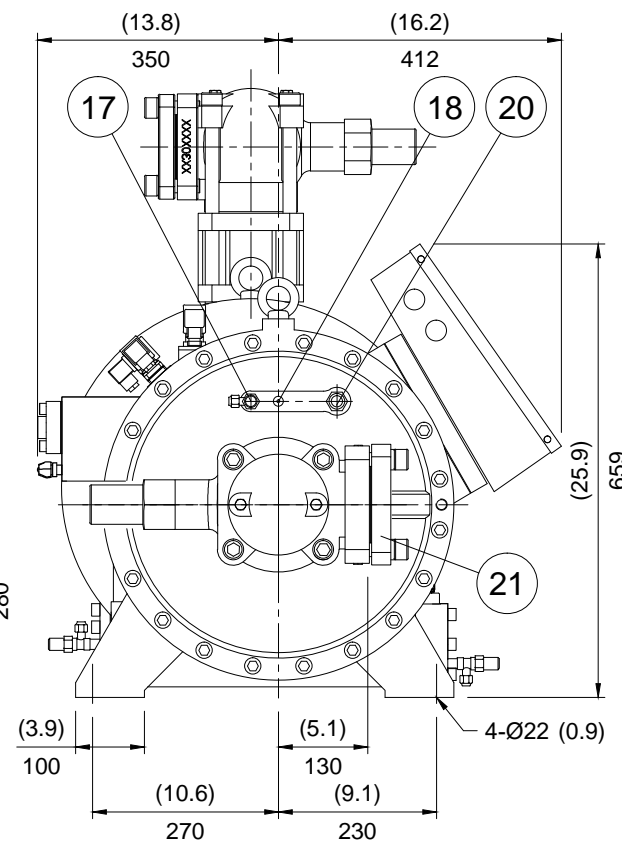
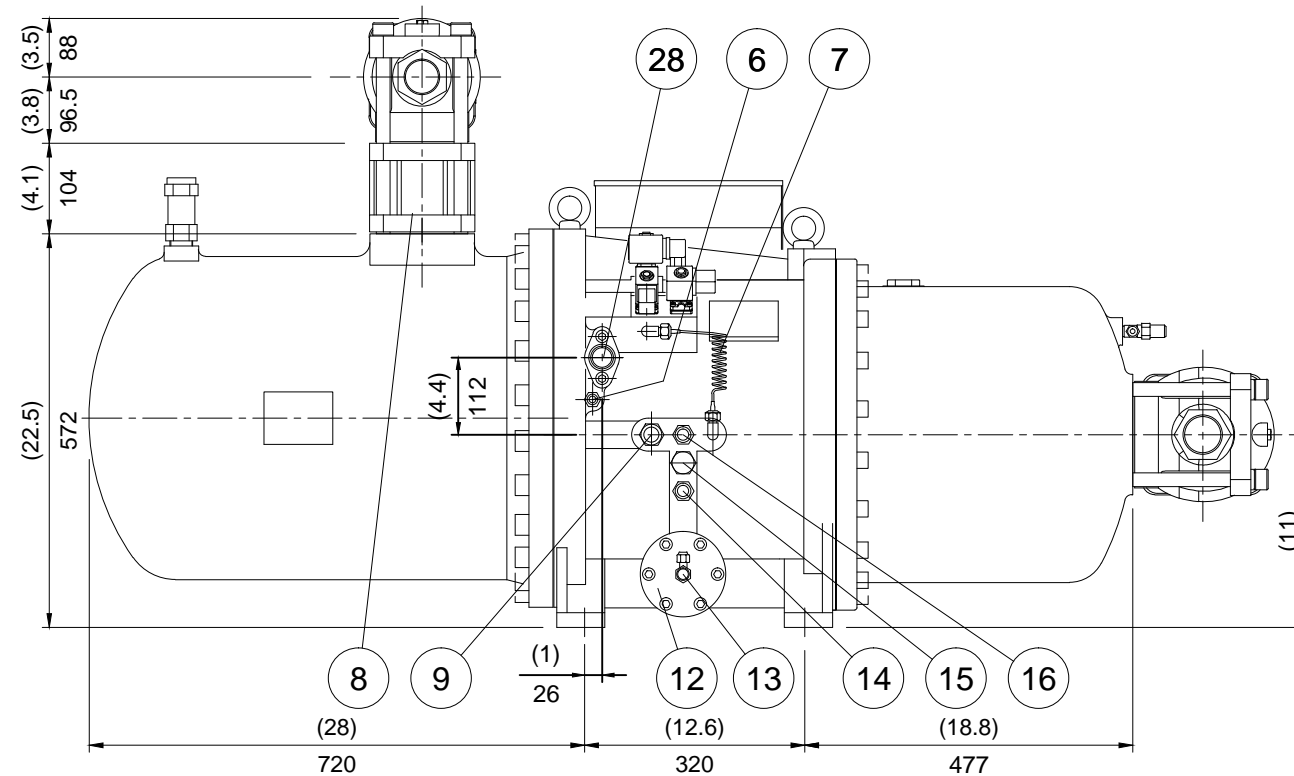

**Micro Control Systems, Inc.**  
 5877 Enterprise Parkway  
 Fort Myers, Florida 33905  
 Tel. (239) 694-0089 Fax (239) 694-0031  
 E-mail: compressors@mcscontrols.com

Model	RC2-550A	
Name	Compressor outline	
		Ver. 06

UNIT  
 SI: mm Imperial: (in)