

Micro Control Systems

APPLICATION NOTE

APP-044

Hanbell PT1000 Temperature Sensor Input to MAGNUM

Revision History

Date	Author	Description
12/26/07	JGW	Create initial version
01/30/09	EAC	Revised Document, Updated the wiring description and diagram on Page 2. Added the Multiplier, divider and offset for Degrees Celsius on Page 3.
07/14/09	JGW	Revised Document, Expanded size drawing, added MCS-Config, MCS-Connect & Magnum software versions required.

Theory

Compressor motor design provides for embedded temperature sensors to provide accurate internal motor temperature. This allows for protection of motor overheating, burnout and emergency shutdown.

Solution

Hanbell offers an embedded PT1000 temperature sensor installed in the motor windings of their compressors. The MCS Magnum controller can directly read this temperature sensor value providing maximum protection.

Wiring of PT1000 Temperature Sensor to Magnum

The PT1000 is a 2 wire thermister embedded in the compressor motor. The two wires terminals are available in the high voltage power box mounted on the compressor labeled as 'B'. Use the following installation instructions:

1. Wire to the analog sensor input selected through the Magnum config.
2. Place a 1.27K ohm resistor from +5 vdc to SI on the Magnum sensor input terminal block.
3. Attach one of the PT1000 staycon terminals in the high voltage power box to Ground on the Magnum sensor input terminal block and attach the other PT1000 staycon terminal to SI on the Magnum sensor input terminal block.

(See Page 4 for High voltage power box terminal drawings)

Magnum Sensor Input Wiring Diagram

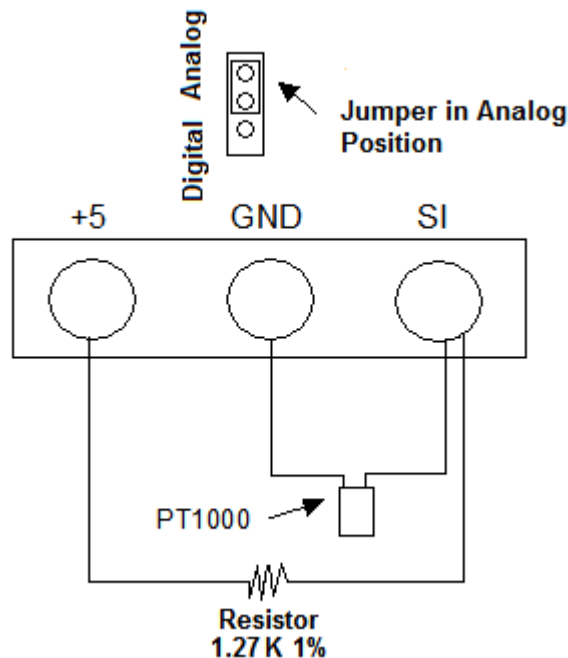

Software Versions Required

To implement the PT1000 temperature sensor you must use the following versions of MCS-Connect & MCS-Config or higher:

1. MCS-Connect Version: 601E
2. MCS-Config Version: 6.01U
3. Magnum Version: 6.02U

Magnum PT1000 Temperature Sensor Setup

IF YOU HAVE THE ABOVE SOFTWARE VERSIONS OR HIGHER SKIP THIS SETUP

During the building of the Magnum Configurer the PT1000 temperature sensor is setup as follows:

1. In the SI Info tab determine where you want to wire the PT1000 sensor.
2. In the 'Display Type' section select User Defined.
3. On the right side of this line under Multiple, Divide & Offset enter 81.0, 35 and -1018.2 for Degrees Fahrenheit. For Degrees Celsius enter 60.0, 46, and -592.6.
4. On the far right, under Select Display Type, select Temp.
5. In the MAG CHL tab, down at the bottom in the Circuit grid, point to this sensor in the Motor Temperature entry.
6. In the Setpoint tab enter in set point 95 the trip value of the discharge temperature.

MCS-CONFIG SI Info Example

Sensor Input Information Screen													
#	Name [1 to 8 char]	Display Type	Offset	Manual Value or NC/NO (select to change)	Display Text (select to change)	Temperature sensor	Humidity Sensor	Auto Manual (select to change)	Circuit Index	Multiplier	Divisor	Off Set	Select Display Type
M-1	SUCT PSI	TI-200	0	68	Not Used	Not Used	Not Used	Manual ...	Not Used	Not Used	Not Used	Not Used	Not Used
M-2	DISC PSI	TI-500	0	175	Not Used	Not Used	Not Used	Manual ...	Not Used	Not Used	Not Used	Not Used	Not Used
M-3	AMPS	CT-100	0	88	Not Used	Not Used	Not Used	Manual ...	Not Used	Not Used	Not Used	Not Used	Not Used
M-4	SUCT TMP	MCST100	0	55	Not Used	Not Used	Not Used	Manual ...	Not Used	Not Used	Not Used	Not Used	Not Used
M-5	DISC TMP	MCST100	0	100	Not Used	Not Used	Not Used	Manual ...	Not Used	Not Used	Not Used	Not Used	Not Used
M-6	OIL PSI	TI-500	0	240	Not Used	Not Used	Not Used	Manual ...	Not Used	Not Used	Not Used	Not Used	Not Used
M-7	LIQ IN	MCST100	0	55	Not Used	Not Used	Not Used	Manual ...	Not Used	Not Used	Not Used	Not Used	Not Used
M-8	LIQ OUT	MCST100	0	55	Not Used	Not Used	Not Used	Manual ...	Not Used	Not Used	Not Used	Not Used	Not Used
M-9	SPAREM-9	SPARE	0	0	Not Used	Not Used	Not Used	Auto ...	Not Used	Not Used	Not Used	Not Used	Not Used
M10	SPAREM10	SPARE	0	0	Not Used	Not Used	Not Used	Auto ...	Not Used	Not Used	Not Used	Not Used	Not Used
M11	SPAREM11	SPARE	0	0	Not Used	Not Used	Not Used	Auto ...	Not Used	Not Used	Not Used	Not Used	Not Used
M12	MOT TMP	User Defined	0	0	Not Used	Not Used	Not Used	Auto ...	Not Used	81.0	35	-1018.2	TEMP
M13	PHASLOSS	DIGITAL	Not Used	Open-OFF	OK, TRIP	Not Used	Not Used	Manual OFF ...	Not Used	Not Used	Not Used	Not Used	Not Used
M14	FLOW	DIGITAL	Not Used	Open-OFF	YES, NO	Not Used	Not Used	Manual ON ...	Not Used	Not Used	Not Used	Not Used	Not Used
M15	RUN/STOP	DIGITAL	Not Used	Open-OFF	RUN, STOP	Not Used	Not Used	Manual ON ...	Not Used	Not Used	Not Used	Not Used	Not Used
M16	SPAREM16	SPARE	0	0	Not Used	Not Used	Not Used	Auto ...	Not Used	Not Used	Not Used	Not Used	Not Used

Liquid Injection Setup using PT1000

To implement liquid injection using the PT1000 embedded motor temperature sensor do the following:

- Liquid Injection set point on = 140, therefore off = 130
- Set HI MOTOR TEMP set point = 150 °f

High Voltage Power Box Terminals

RC10 & RC11

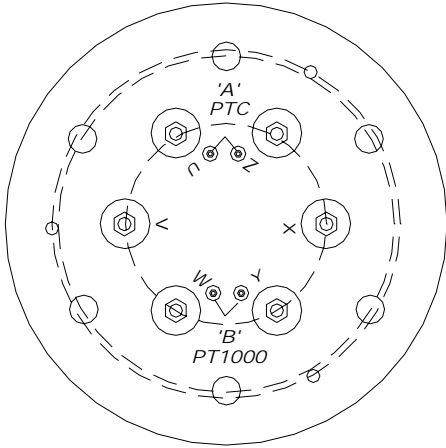

RC10-11
LA1-9

RC12 thru RC21

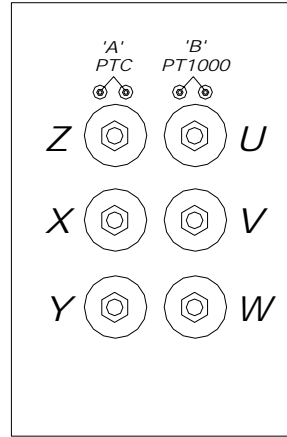

RC12-21

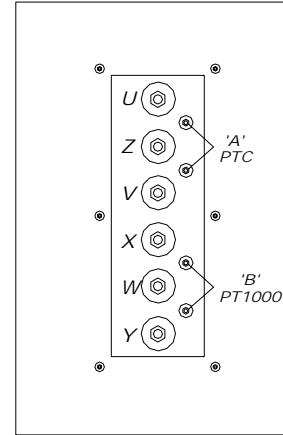

RC22-24

PT1000 Temperature

T°F	T°C	Rt	Vo
(°F)	(°C)	(K)	(Volts)
86.0	30.0	1.117	2.3256
95.0	35.0	1.136	2.3468
104.0	40.0	1.155	2.3676
113.0	45.0	1.175	2.3880
122.0	50.0	1.194	2.4080
131.0	55.0	1.213	2.4278
140.0	60.0	1.232	2.4471
149.0	65.0	1.252	2.4662
158.0	70.0	1.271	2.4850
167.0	75.0	1.290	2.5034
176.0	80.0	1.309	2.5215
185.0	85.0	1.328	2.5394
194.0	90.0	1.347	2.5569
203.0	95.0	1.366	2.5742
212.0	100.0	1.385	2.5912